

P
25-5
LON
1974
D456

CENTRE INTERNATIONAL DE RECHERCHE EN AMÉNAGEMENT LINGUISTIQUE	INTERNATIONAL CENTER FOR RESEARCH ON LANGUAGE PLANNING
CIRAL Pavillon Charles-De Koninck Université Laval Québec, Canada, G1K 7P4	

JUL 16 1975

**A SOCIO-PHONETIC STUDY
OF A QUEBEC FRENCH COMMUNITY: TROIS-RIVIERES.**

Denise Deshaies-Lafontaine
Department of Phonetics, University College London

Thesis Submitted for the Degree of Doctor of Philosophy
University of London

ABSTRACT

This study of urban dialectology consists of an investigation of some aspects of the French phonological system in the city of Trois-Rivières, Province of Québec. The corpus of data includes a series of sixty recorded interviews which provides comparable speech samples from a significant cross-section of Trifluvians, who are stratified according to age, sex, occupation and education. The data obtained from these interviews represent the sociolinguistic variation existing in Trois-Rivières and the inter-individual diversity within this speech community.

Descriptions on the methods of sampling, collection of data, the quantitative analysis of phonological variables, and interview construction eliciting different speech styles are made in chapter 1, together with a general description of the situation of the French language in Québec and Canada.

To study the variation existing in the Trifluvian speech community, seven phonological variables are subjected to special examination. These consist of four vocalic variables, i.e. (a), (è), (eu), (o), and three consonantal variables, namely (g), (ch), (r). The analysis of the co-variation of these phonological variables and sociological and stylistic factors is made throughout chapter 2. In this latter chapter, questions concerning the extent of the linguistic variation present, the causes of linguistic diversity and the process of linguistic change are also treated.

Chapter 3 is devoted to the examination of general attitudes of speakers towards language and to the correlation of their subjective attitudes with their objective linguistic behaviour observed in chapter 2.

The final chapter, or the synthesis, studies the processes in which the variables are involved and their consequences for the evolution of the Trifluvian sociolinguistic system.

Acknowledgements.

The work presented here was carried out under the direction of Professor A.C.Gimson. It is impossible to acknowledge properly my indebtedness to him as his influence may be seen in the overall focus of this work.

Discussions with Dr.D.Hudson and Mr.W.Downes have brought the most valuable insights into the problems of sociolinguistic analysis.

I am also much indebted to Mr.Al Bartolucci, without whose help, the statistical treatment of the data would have been much more difficult.

The financial support of the Ministère de l'Education, Québec, throughout the major part of this study, is gratefully acknowledged. The linguistic survey of Trois-Rivières was conducted on the basis of the survey carried out by the Centre d'Etudes en Loisirs of the Université du Québec, Trois-Rivières. For permission to use the data, I am deeply indebted to the Centre d'Etudes en Loisirs. I am also very grateful to all the Trifluvian people who co-operated with me as informants.

Table of contents.

Abstract	2
Acknowledgements	4
Table of contents	5
List of Maps, Tables, Figures and abbreviations	9
<u>Chapter 1</u> : Introduction	14
1.0 Introduction: Language and its study in a speech community perspective.	15
1.1 Trois-Rivières as part of a Québec French speech community.	18
1.1.1 French in Québec and Canada.	20
1.1.2 Language conflict	22
1.1.3 Responses to Québec French	24
1.1.4 Social diversification	26
1.1.5 Linguistic variation	28
1.1.6 Collection of a representative corpus of data	30
1.2 Setting of the survey: Trois-Rivières	33
1.2.1 History and economic activity of Trois- Rivières	34
1.2.2 Some data on the population	39
1.2.3 Sampling procedure	41
1.2.4 Geographical distribution	46
1.2.5 Occupation and education	50
1.2.6 Place of origin	52
1.2.7 Summary	52
1.3 Data	53
1.3.1 Conduct and content of interviews	53
1.3.2 Phonetic transcription	57
1.3.3 Summary on statistical methodology	57
1.3.4 Summary	63

<u>Chapter 2: Study of the co-variation of phonological and sociological variables.</u>	64
2.0 Scope of the study	65
2.1 Phonemic inventory of Trois-Rivières French	67
2.1.1 The variable (a)	74
2.1.2 The variable (è)	77
2.1.3 The variables (o) and (eu)	78
2.1.4 The variables (g) and (ch)	79
2.1.5 The variable (r)	80
2.2 Variable (a)-1 and the sociological variables	83
2.2.1 Phonological and syntactic conditioning	87
2.2.2 Phonological and stylistic conditioning	90
2.2.3 Differentiation by education	94
2.2.4 Differentiation by occupation	104
2.2.5 Differentiation by sex	107
2.2.6 Differentiation by age	110
2.2.7 Conclusions	114
2.3 The study of archaic phonetic features	123
2.3.1 Historical notes	123
2.3.1.1 Variable (a)	124
2.3.1.2 Variable (è)	128
2.3.1.3 Variable (eu)	130
2.3.1.4 Variables (g)and(ch)	131
2.3.2 Archaic phonetic features viewed as stereotypes	131
2.3.3 Co-variation of linguistic stereotypes and sociological parameters	139
2.3.3.1 Differentiation by education and sex	139
2.3.3.1.1 Linguistic stereotypes and more educated informants	144
2.3.3.1.2 Linguistic stereotypes and less educated informants	146
2.3.3.1.3 Summary	153
2.3.3.2 Differentiation by occupation	157
2.3.3.3 Examples of speech illustrating use of linguistic stereotypes	161

2.3.4	"Joual": a speech variety of Québec French	167
2.3.5	Conclusions	173
2.4	The study of long vocalic segments, i.e. /ɛ œ œ ɔ/	177
2.4.1	Vowel length	177
2.4.2	Québec French long vowels	177
2.4.3	Diphthongization: General Outline	184
2.4.3.1	Differentiation by age	190
2.4.3.2	Differentiation by education	194
2.4.3.3	Differentiation by occupation and sex	202
2.4.3.4	Conclusions	212
2.4.3.5	Summary	222
2.4.4	Opening of half-open segments	224
2.4.4.1	Phonetic conditioning	224
2.4.4.2	Age factor	226
2.4.4.3	Education factor	233
2.4.4.4	Occupation and sex factors	237
2.4.4.5	Conclusions	242
2.5	Conclusions on the vocalic variables	246
2.6	Variable (r)	252
2.6.1	Variable (r)-1	252
2.6.1.1	The structure of variation of variable (r)-1	254
2.6.1.2	Summary	263
2.6.2	Variable (r)-2	265
2.6.2.1	Phonetic conditioning and historical perspective	265
2.6.2.2	r-deletion: a case of "inherent variability"	273
2.6.2.3	Differentiation by education	278
2.6.2.4	Differentiation by occupation	283
2.6.2.5	Differentiation by sex	285
2.6.2.6	Summary	291
2.6.3	Conclusions on variable (r)	294

<u>Chapter 3: General attitudes towards Trois-Rivières French</u>	300
3.0 Subjective attitudes towards Trois-Rivières French	301
3.1 Recognition of Trifluvians by outsiders	302
3.2 Recognition of linguistic differences between country and town	306
3.3 Recognition of social accents within Trois-Rivières	307
3.4 Attitudes towards "joual"	310
3.5 Attitudes towards Trois-Rivières French	314
3.6 Efforts to change one's own language and recognition of one's different levels of language	316
3.7 Is language a factor through which judgments can be made?	319
3.8 Differences in linguistic attitudes of various groups	320
3.9 Summary	326
 <u>Chapter 4 : Synthesis</u>	 328
4.0 The nature of variability	329
4.1 Constraints of phonological environments	332
4.2 The structure of stylistic variation	335
4.3 Social structure	339
 <u>Conclusion</u>	 351
 Appendix : The questionnaire	 353
 Bibliography	 368

List of Maps, Tables, Figures
and abbreviations.

Maps

Map 1. General map of the Province of Québec	32
Map 2. Trois-Rivières: industrial parks and main industries	38
Map 3. Trois-Rivières: socio-demographic areas	48
Map 4. Geographical distribution of respondents within Trois-Rivières according to the socio-demographic areas.	49

Tables

Table 1: Trois-Rivières: Industries (over 200 employees)	37
Table 2: Population by ethnic group	39
Table 3: Population by religious denomination	40
Table 4: Population by Mother Tongue	40
Table 5: Official language and language most often spoken at home	41
Table 6: Quotas of informants by sex, age and occupation	44
Table 7: Distribution of respondents by occupation, education, age and socio-demographic areas	51
Table 8a: Trois-Rivières French phonemes according to an articulatory phonetic classification	69
Table 8b: Trois-Rivières French phonemes according to a binary distinctive phonetic features classification	71-72
Table 9: Average percentage of [a] for the 60 informants by environment and style	90

Table 10:	Proportional responses to [a] by environment, education and style	94
Table 11:	Proportional responses to [a] by environment, sex and style	108
Table 12:	Proportional responses to [a] by environment, age and style	111
Table 13:	Percentages of responses to 7 archaic phonetic features by education, sex and style	140
Table 14:	Phonetic effects of the length feature on the realization of /ɛ a œ ɔ /	182
Table 15:	Averaged percentage of diphthongization for all informants by environment and style	185
Table 16:	Proportional responses to diph- thongization of four vocalic elements by age and style	192
Table 17:	Proportional responses to diph- thongization by environments, education and style	195
Table 18:	% of responses to diphthongized vocalic segments by environment, education and style	200
Table 19:	% of responses to diphthongization by environment, occupation, sex and style	202
Table 20:	Proportional responses to open segments by age, environment and style	227
Table 21:	Proportional responses to open segments by education, environment and style	233
Table 22:	Proportional responses to open segments by occupation, sex, environment and style	238
Table 23:	Phonetic realizations of /ɛ a ɔ œ /	247
Table 24:	Use of [r] and [R] for sixty informants by environment and style	255-57
Table 25:	Proportional responses to [R] by envi- ronment, age and style	260
Table 26:	Proportional responses to [R] by envi- ronment, education and style	261

Table 27: Proportional responses to r-deletion by 5 vocalic environments, occupation and style.	271
Table 28: Proportional responses to r-deletion by environment, age and style	276
Table 29: Proportional responses to r-deletion by environment, occupation and style	284
Table 30: Responses to questions on linguistic attitudes by sixty Trifluvian informants	303-04

Figures

Fig.1: % of responses to [a] in a non-final syllable by education and style	101
Fig.2: % of responses to [a] in a final free syllable by education and style	101
Fig.3: % of responses to [a] in a final closed syllable by education and style	101
Fig.4: % of responses to [a] in a non-final syllable by occupation and style	104
Fig.5: % of responses to [a] in a final free syllable by occupation and style	104
Fig.6: % of responses to [a] in a final closed syllable by occupation and style	104
Fig.7: % of responses to [æ] by occupation and style	158
Fig.8: % of responses to [wɛ:] by occupation and style	158
Fig.9: % of responses to [we] by occupation and style	158
Fig.10: % of responses to [e:] by occupation and style	158
Fig.11: % of responses to [h] by occupation and style	158
Fig.12: % of responses to [x] by occupation and style	158
Fig.13: % of responses to [œ:] by occupation and style	158

Fig.14:	% of diphthongization of each vowel by style, for all informants	186
Fig.15:	% of diphthongization of /ɛ/ by age and style	191
Fig.16:	% of r-deletion in the environment -V(r)C by education and style	280
Fig.17:	% of r-deletion in the environment C(r)w by education and style	280
Fig.18:	% of r-deletion in the environment -V(r)P by education and style	280
Fig.19:	% of r-deletion in the environment -V(r)PPC by education and style	280
Fig.20:	% of r-deletion in the environment -C(r)P by education and style	280
Fig.21:	% of r-deletion in the environment -V(r)C by sex and style	286
Fig.22:	% of r-deletion in the environment C(r)w by sex and style	286
Fig.23:	% of r-deletion in the environment -V(r)P by sex and style	286
Fig.24:	% of r-deletion in the environment -V(r)PPC by sex and style	286
Fig.25:	% of r-deletion in the environment -C(r)P by sex and style	286

Abbreviations

Sociological

P = Professional

WCW = White collar worker

MW = Manual worker

M = Male

F = Female

Linguistic

IPA = International Phonetic Association

ALF = Atlas linguistique de la France

RS = Reading style

CS = Careful style

FC = Formal conversation

Chapter 1

INTRODUCTION

1.0 Introduction: Language and its study in a speech
community perspective.

A causal relationship exists between social structure and language, since social interaction is a process involving communication, itself relying primarily on the use of language. Joyce O.Hertzler defines language in the following terms:

" A language is a culturally contrived and socially established system of standardized and conventionalized symbols. As a system it is a body of self-consistent, rule governed, interfunctioning parts. The constituent symbols have specific and arbitrarily imposed meaning and common usages for purposes of socially-meaningful expression and for communication in the given society"
(1).

There are different views representing the relationship between social and linguistic structures. One view is that represented by Chomsky, where language is considered as fundamental, cause, an independent variable. Language structure is interesting in that it is considered as directly embedded in the fundamental character of the human mind, and its study takes into account an ideal speaker-listener in an homogeneous community (2). The notion related to this linguistic approach is the well-known notion of "competence". Chomsky's competence involves the control of a speaker over a limited set of rules governing the use of language, i.e. the abstract knowledge of the rules of language. What is mainly focused on is the elaboration of deep and abstract regularities underlying occurring speech patterns, where the ability to act rather than the actual

(1) Joyce O.Hertzler. (1966). p.173

(2) cf. N.Chomsky. (1965). p.3

performance, or the actual selection and execution of rules, is considered. Such point of view is of great interest since its level of abstraction reaches the processes by which the human brain selects and thereafter operates.

When one tries to explain the logic of the human brain however, one has to discount irregularities since these are considered as irrelevant to such level of abstraction. On the other hand, when one seeks to understand language as the instrument of communication of a speech community (1), one has to take into account irregularities as well as regularities of speech. The social structure of the community plus the ways in which this community is making use of language must also be considered. The view emphasizing the co-existence of linguistic and social structures does not however see one as prior to the other, but rather as being both co-occurring and co-determining. Some of the linguistic fluctuations occurring in the study of speech within a heterogeneous community may not seem to enter into a generative perspective. If they are however correlated with external factors, they may prove to be part of a system, as well as those rules predicted by grammar, phonology, etc. The irregularities found may also appear to be part of the intuitions of a speaker, therefore being also predictable and coherent, and may reflect social and stylistic constraints.

A basic assumption underlying the search for a demonstration of the systematicity of relationships between social structure and language use, is that speakers are able to operate not only in terms of rules of grammar,

(1) "Speech community" is understood in Labov's sense, i.e. where a common set of normative values in regard to linguistic features is present. cf. Labov.(1970). Note 40, p.202. Cf. also D.Hymes.(1971b). pp.64-65.

but also in terms of cultural rules, i.e. that speakers have internalized rules of usage which are shared by other members of their society.

The point of view taken in this work shares the one stated above, in that it focuses on the "communicative competence" (1) of speakers. The speaker-listener is regarded, as a matter of basic assumption, as being part of a particular community, who knows the obligatory rules which govern his language as well as the rules governing the use of optional rules. A speaker-listener is seen to be able not only to act, but also to act in conformity with, in respect to, in agreement or disagreement, etc. To take into account all these factors involves the recognition of the heterogeneity of speech communities, and of the extent to which variation in usage carries socio-stylistic meaning, i.e. of the structure of linguistic variation.

The recognition and the attempt to deal with the fact of the non-homogeneity of language have been represented in the works of sociolinguists such as Labov, Fishman, Gumperz, Hymes, Bernstein, etc. The following work may therefore be seen as part of the trend towards studies dealing with heterogeneous speech communities which seek to deal with and draw conclusions from the diversity and variations present in linguistic data.

In the course of such study, important linguistic problems will be treated, such as the nature of the linguistic differences which predominate in often fine distinctions between styles of speech, groups of speakers, etc., and the mechanism of linguistic change. Mainly, therefore, this work will be concerned with problems of interest to linguistics. The study which follows is the first of this kind

(1) cf. D.Hymes. (1971c). pp.269-293.

which has been applied to the speech of a urban community in Québec, namely Trois-Rivières. At the time this investigation began, two similar works were carried out in the Province of Québec, namely those of G.Sankoff, Cedergren, and their associates in Montréal, and of N.Beauchemin in Sherbrooke. The present work is therefore an attempt to contribute to the present research on Québec sociological urban dialectology.

1.1 Trois-Rivières as part of a Québec French speech community.

The work which is reported in this study is an investigation of language as it is used in the social context of a urban community, Trois-Rivières. Differences in linguistic behaviour as well as within the social structure are encountered in this speech community. The variability arising from these differences is seen as an integral part of the linguistic system as well as part of the behaviour of the city.

Trois-Rivières constitutes a single speech community. Native Trifluvians show different patterns of behaviour in terms of the absolute values of the phonological variables investigated, but the patterns of style shifting between different speech situations follow the same pattern in many cases. Moreover, subjective attitudes of Trifluvians towards their language are in close correlation with their objective patterns of behaviour towards phonological variables.

Although Trois-Rivières constitutes a single speech community, it is also part of a larger one, namely that of the Province of Québec (1). Only 18% of the sixty informants interviewed reported that when they travelled outside of the city, they were identified as Trifluvians because of their speech. The common shared experience has rather been that the informants were identified as speaking Québec French rather than Trois-Rivières French (cf. chapter 3, section 3.1). Moreover, the different pronunciations attributed to the phonological variables, such as the possible diphthongization of long vocalic segments (cf. chapter 2, section 2.4.2), are found not only in Trois-Rivières but also in other areas of Québec, so that they constitute features of general Québec French. The subjective positive or negative attitude of speakers directed towards their speech is very often associated with the value attributed to general Québec French, rather than that given to Trois-Rivières French. Finally, major industries of Trois-Rivières are in the hands of an English-speaking minority, so that conflicts between English and French arise and negative linguistic attitudes towards French may result from this situation, as it is generally the case in Québec (2).

The above factors have been mentioned since it is felt necessary to take account of the situation of the French language in Québec and in Canada and of its status, if the reactions of Trifluvians towards phonological variables and their attitudes towards language are to be better understood.

- (1) Hereafter, Québec will be used for "Province of Québec". The capital of the Province will be designated as Québec City.
- (2) cf. chapter 3. Cf. also W.E.Lambert.(1972), for negative linguistic attitudes towards French.

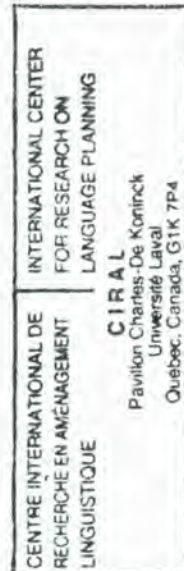

1.1.1 French in Québec and Canada.

' Before 1763, Canada was a French colony. The population consisted of people coming mostly from the following provinces of France: Normandie, Perche, Picardie, Maine, Brie, Champagne, Beauce, Ile-de-France, Poitou, and Anjou. The settlers coming from these different areas brought with them their culture, religion, and law. However, because of the small number of people and because of the close contact between them, uniformity of language was rapidly reached, long before such uniformity was reached in France.

The French-speaking population's numerical superiority in Québec helped them maintain their culture, including language and religion, after the defeat and consequent subjugation to the British crown in 1760, sealed by the Treaty of Paris of 1763. Though the British North America Act of 1867, establishing the Canadian confederation, gave official status to the French language, Canada becoming an official bilingual country at the national government level, individual citizens stated monolingual in everyday life. Even nowadays, while the whole country in itself may be officially called bilingual, its component states are restricted to one language. Only one State, Québec, gave the English language, by law, an equal status with the French language with respect to economic, social and political life (1), whereas the French language

(1) The recent Official Language Act (Statutes of Québec, Bill no.22, 31-07-1974) makes French the official language of the Province. The effect of this Act is to "ensure the preeminence of that language and to promote its vigour and quality;" without, however, affecting the vested rights of the English language.

The exact effects of this Act on the use of the English language in the Province, as for example in the work world (cf. section 1.1.2) remain to be seen, since the true significance of the Act will be made specific in the regulations based upon it.

has not been guaranteed the same legal status in the other nine English speaking States.

Today, French Quebecers form an over 80% majority in their own State of Québec, whereas elsewhere in North America they and other French settlers are only a small minority, except in the case of Acadians who have almost reached parity with the English speaking majority in New Brunswick. The predominance of French in Québec has however not been sufficient to reduce the political, socio-economic, cultural, and psychological inferior status attributed to the French culture after 1763. Internally within Québec, foreign domination of the economy has remained almost intact to this day. As a result of the foreign and English Canadian investment, the ownership and management of most of Québec's basic industries has been in the hands of the English-speaking minority, while French Quebecers were relegated to less skilled work or to professional and government careers, with careers in industry and business being reserved for the English speaking minority.

The sustained British domination of Québec has had by now deep effects on the French-speaking population: having lost at first, through the British takeover, most of its link with France, most of its intellectual leadership, except for the clergy, and of its political and economical self-determination, most French Quebecers have lost much of their former pride and self-confidence. This lost of pride has extended to language, from which negative feelings about French in Québec have arisen. Although there have been reactions to this collective submissiveness, as in 1837-38, only the last decades of the 20th century have brought to French Quebecers a new feeling of self-assertion and political movement aiming at self-determination.

1.1.2 Language conflict

The two major languages of Canada, English and French, do not have the same importance in the various states of the country and for its different members. Their relative importance in Canada and in the Province of Ontario is the reverse of the situation in Québec, the only Canadian province where French is dominant. Whereas French is the second major language of Canada, English is the second language of Québec only because it enjoys legal protection there, a privilege denied to French in other provinces.

English, being the language of the minority in Québec, has its legal status strengthened in practice by its wider functions in that it is preferred for communication between ethnic groups and is the preferred language of the work world. This is directly related to the socio-economic hegemony of the English minority, whereby English management communicates with French workers in English. Lieberson describes the status of English as follows:

"Canada's industrial, commercial, and financial worlds are dominated by Canadians of British origin and important American and British companies who together make English the language of big business and industrial power. As one goes up the hierarchy, English is increasingly the language of communication. Accordingly, in many facets of Québec's economic life, the ambitious French Canadian faces far greater pressure to learn English than does an English monoglot to learn French. Further, English is the language of technology in Canada, providing an additional incentive for bilingualism among French Canadians" (1).

(1) S.Lieberson.(1970), p.22

The inevitable consequence has therefore been that French workers use English or at least a kind of French which makes extensive use of English terms.

The conflict between English and French applies in various domains, such as business, industry, government, mass media, education, and private life. This conflict is strengthened in Québec by the income advantages for bilingualism. If Montréal is taken as example, it can be observed that, holding educational achievement constant, the percentage of native French speakers who are bilingual varies from occupation to occupation in direct relation to the income advantage that bilingual French enjoy over French monoglots. As Lieberson states:

" Thus, there is further evidence for a rather persistent theme: a relative absence of strong economic pressure among the British to learn French, but the presence of a distinct gain for French Canadians who acquire English as a second language" (1).

The importance of income as a factor is moreover emphasized by the fact that "[b]ilinguals of French ethnic origin (...) earn less than those of British origin (...) even after education is taken into account" (2). Thus, if education is held constant, it appears that there is no income difference between English monoglots and English bilinguals, whereas an important income gap is found between English bilinguals or monoglots and French bilinguals, and finally between French bilinguals and French monoglots. Hence, there is a strong economic incentive for bilingualism among the French, whereas this incentive is absent among the English.

(1) S.Lieberson. (1970), p.174

(2) Id., p.170

The income advantages affecting bilingual speakers concern not only the native French but also other ethnic groups in Montréal. Bilingual speakers of other ethnic groups earn more than monolinguals of either French or English. However, those who speak only English earn more than those who speak only French. Granted this income advantage, English becomes a more desirable first language to acquire for those whose native tongue is neither English nor French.

This situation leads to the following reality: the French ethnic population is virtually the sole carrier of the French mother tongue, whereas speakers of British origin are assisted by the other ethnic groups who generally favour English over French by an enormous margin. In 1961, for example, 97% of all Canadians with a French mother tongue were members of the French ethnic group.

The above factors indicate that the conflict between English and French is likely to be settled in favour of English, since use of this language represents economic advantages and social mobility. From the importance of English in the work world and from the economic advantages resulting from its use, the survival of French even in Québec cannot be taken for granted and will require much effort and determination, if Québec wishes to survive as a French island in English North America.

1.1.3 Responses to Québec French

Given the socio-economic inferior status of the average French Quebecer compared with the status of the

average member of the English minority in Québec, and given the importance English has in Québec as a more prestigious language in specific domains of interaction, as for example in the work world, it is not surprising that French Quebecers themselves associate their negative ethnic image with their language, Québec French. Social psychologists, like W.E.Lambert (1967,1972), established the prestige order of language and varieties of language in Québec through personality evaluation tests or what is called the "matched guise technique". They obtained more favourable evaluations for bilingual speakers when they appeared under their English rather than their French guises. Moreover, voices using Standard French were more favourably evaluated than those representing usage of Québec French. A speaker using English was judged more favourably when intelligence, ability, etc. came into play, whereas the same speaker using Québec French was rated more favourably only under sociability and religious factors.

On the other hand, French Quebecers respond more ambivalently with direct questioning. Thus, French speakers may deny the prestige accorded to Parisian French speakers, by strongly rejecting such a form of speech for themselves and other members of the community. On the other hand, speakers demonstrate their negative attitude towards Québec French by showing a conscious need to correct its pronunciation, to improve its vocabulary and syntax, and to eliminate English terms, etc. (cf.chapter 3).

Consciousness of the danger which French is facing leads to an alignment with Standard French, i.e. a norm has to be found in order to establish Québec French as a "high"

language, i.e. as a language carrying prestige (1). On the other hand, French speaking Quebecers are increasingly taking key positions in all domains of the economic and political life of the Province, due to their higher educational level. English is therefore increasingly seen as superfluous, except as a means of communication with other provinces and countries, in view of its lack of domain separation and situational need. As a result of this, Québec French is seen more and more as prestigious since it represents a search for self-determination. At the same time, considerable efforts are directed towards the refrancization of the work world. These efforts have had greater success in the last few years, mainly due to the new political assertiveness of French Quebecers and consequent practical measures by the Québec government, such as the recent Official Language Act (2). At present, it is not however clear whether a modified international Standard French can be generalized in Québec, or whether a more extensively Québec French Standard will evolve as happened in the case of American English.

1.1.4 Social diversification

In most cities of Québec, as in other industrialized Western societies, social organization becomes an essential part of modern life in order to coordinate the many activities of this society into extensive division of labour and a hierarchy of leadership. This phenomenon leads

(1) For "high" and "low" language, cf. C.A. Ferguson. (1959), and section 2.4.3

(2) cf. section 1.1.1 p.20

to a society stratified into social classes. There are many definitions of social class, socio-economic class, etc., in the sociological literature. There would be little point in attempting to discuss these topics here. Nevertheless, it should be mentioned that the notion of "class" forms a continuum, i.e. that boundaries between classes are often hard to determine. However, it may be said that social class depends mainly on occupation, education, income, size and location of home, etc. (1). The social distance between social classes is much smaller in industrialized societies than in caste societies for example, since there is a high potential for social mobility.

An additional aspect of social classes is that they are ranked in a social prestige hierarchy, so that people may react to others from different classes as superiors and inferiors. For many people the social class of others is as important as sex and age, and is often recognized from clothes, sets of conventions and values, speech, etc.

Language is a form of social behaviour, and since there is variation in the social structure itself, it is not surprising to find linguistic variation. The expression of different sets of values and norms, the process of identification as between one group of the society and another, etc. are transmitted through many channels, language being one of them.

(1) cf. M.Argyle. (1967), for discussions on the notion of social class.

1.1.5 Linguistic variation

Geographical as well as social factors are important determinants of linguistic variation in Québec. Socially determined varieties of Québec French are ordered along a continuum, the extremes being: Standard French and urban Québec French, or "joual". "Joual" is mostly characterized by its high degree of English borrowing as well as by its usage of archaic linguistic features (cf. chapter 2, section 2.3.4). The greatest number of speakers in Québec use "joual" and what can be referred to as "cultivated" Québec French, Standard French being restricted to a small minority. It would seem that upper class French Quebecers tend to use Québec French, whereas workers would prefer "joual". Whereas bilingualism implies a choice between English and French in Québec, it is also to be assumed that a speaker has also the choice between various varieties of Québec French. The choice of one or another variety within one language is highly dependent on the desire of a speaker to identify with a specific group or on his desire to become a member of another group (cf. Labov. (1966a).). In general, social attitudes and roles are determinant in linguistic variation, especially in the case of imperfect adoption of a desirable model, as expressed by speakers who want to correct their language (cf. chapters 2 and 3). In Québec, for example, language choice may operate in favour of English in interethnic communication and in the work world, and choice in varieties of Québec French may depend on subjective feelings concerning the value attributed to this language. Thus, for example, in a Québec university, extreme varieties along the sociolinguistic continuum, i.e. Cultivated Québec French and "joual", may be used side by side

among speakers of similar social status (1).

Labov (1966a) has formulized the effect of social and stylistic factors in describing the contingencies of occurrence of particular phonological and grammatical variants of English in terms of "linguistic variables". These are sets of factors determining linguistic variation.

The varieties of French found in Québec form a linguistic continuum, i.e. there is a question of degree in the incidence of certain linguistic features which differentiates them. Trois-Rivières is a city which has all the forms of speech found in Québec, i.e. from a more Standard French, through a Cultivated Québec French up to "joual". The degree to which a Trifluvian will select phonological forms related to one variety or the other, thus leading to linguistic variation, will depend on factors such as those elaborated by Labov.

Given the conflict between English and French within Trois-Rivières, and given the search for a linguistic norm, ethnolinguistic attitudes and the type of situation involved will be important factors in accounting for variation. Given furthermore the degree of urbanization of this city leading to occupational and educational differences, social factors such as occupation, education, sex, and age will also be significant in representing linguistic variation. Thus, Trois-Rivières appears to be a highly representative city of the complex situation of French in Québec. It will be interesting to study linguistic variation within Trois-Rivières since the value attributed to any one variety of Québec French will appear more clearly. Especially, it will

(1) cf. Mimi Beaudry Losique.(1974).

be possible to focus on the importance of stylistic and social factors in accounting for variation within a single urbanized speech community.

1.1.6 Collection of a representative corpus of data.

The analysis of linguistic phenomena based on the notion of speech community and on the recognition of the complex organization of this community into social classes involves the collection and analysis of a corpus of data which adequately represents the speech of all groups of this speech community. A systematic collection must be made through sampling, in order to have all dimensions of variability existing in the community represented.

A speech community sample does not however need to include as many informants as in other behavioral surveys. A speech community is in fact defined as:

" any human aggregate characterized by regular and frequent interaction by means of a shared body of verbal signs and set off from similar aggregates by significant differences in language usage " (1);

and, because people are in frequent and regular interaction, they can be assumed to understand each other efficiently, this placing a limit on the extent of variation which can exist within the community. There is a consistency of speech necessary for effective communication.

It has been found in studies of complex urban

(1) J.J.Gumperz. (1968), p.219

speech communities, that a well stratified sample of between 50 and 150 speakers can represent the whole range of variation existing within a community (1). The sample need however be well chosen in order to be representative of all social sub-groups.

Section 1.2 et seq. will be devoted to the description of the speech community studied, and to the details of sampling procedure and collection of data.

(1) cf. Labov, (1966a); P.Trudgill, (1974); G.Sankoff and H.Cedergren, (1971), etc.

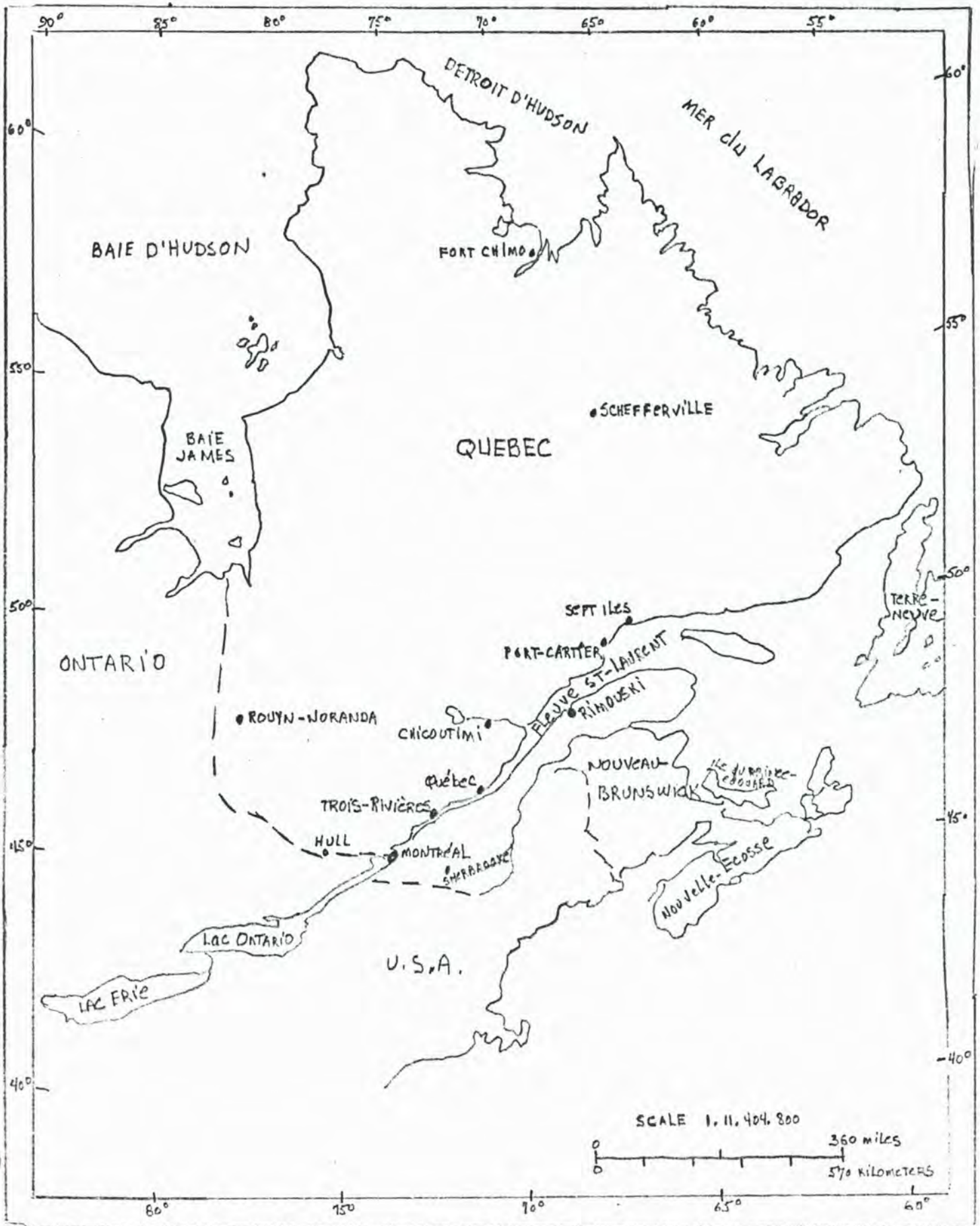

Map 1 : General Map of the province of Québec.

1.2 Setting of the survey: Trois-Rivières.

Sociolinguistic research seeks to understand linguistic structures as they are embedded within a social and cultural matrix. The details of phonology and of any other linguistic interests are examined within the context of their use. Therefore, an interest in the nature and extent of the diversity within a given speech community arises, followed by that of how such a diversity reflects social stratification, language change, the possible communicative functions of particular linguistic forms, etc.

The research aims of sociolinguistics have, because of both linguistic and social interests, to rely on methodological perspectives and techniques drawn from linguistics and sociology. From linguistics, detailed linguistic data are required, and from sociology sampling techniques, in order to make certain that the speech of all relevant segments of a population is well represented.

Therefore, it is necessary to select phonemes which may have a sociolinguistic connotation, to make use of sampling techniques, and to obtain high quality recordings in order to present a comprehensive and socially relevant understanding of a complex urban sociolinguistic system.

The speech community studied is located in the city of Trois-Rivières, which is the centre of the most populated part of Québec, namely called "le coeur du Québec".

Geographically seated half-way between Montréal

and Québec City on the North shore of the St.Laurent River, Trois-Rivières is the gateway to the St.Maurice Valley, and a major commercial and industrial centre. With an area of 39.91 square miles or 19,792 acres, the city of Trois-Rivières is bounded to the north-east by the St.Maurice river, to the south-east by the St.Laurent River, to the south-west by the municipality of Trois-Rivières-Ouest (towards Montréal) and to the north-east by the municipality of St.Etienne-des-Grès. It is at 46°-21' latitude and 72°- 33' longitude.

Trois-Rivières owes its name, life and economic development not to "three" rivers, but to one, the St.Maurice, which the Amerindians called Métabérotine, i.e. a sheet of water exposed to all winds. At its mouth, the river flows between the two largest Islands (de la Potherie and St. Quentin) of its delta, forming three channels. This river, whose shift falls produce over 2,000,000 hp and on which 100,000,000 pulpwood logs are floated each year from up the valley, has determined the city's industrial future, namely its largest paper mills. Trois-Rivières was the first town in Canada to boast heavy industry, the famous "Forges du St.Maurice" (1729) , and the only one ever to produce super canoes (35 to 40 ft.long) in birch bark. These were used by travellers and fur tradesmen in the last century. In the mid-19th century, the industry began to expand with the tapping of forest resources. Lumbering rights along the St.Maurice river were first granted in 1831.

1.2.1 History and economic activity of Trois-Rivières.

In the period of the first French settlement of Canada in the seventeenth century, Trois-Rivières formed

the gateway to a far-flung trading empire in the watershed of the St. Maurice River and its numerous tributaries which extend far northwards into the Laurentian hinterland, and it early became important in the history of the Roman Catholic Church. Franciscan missionaries came out from France as early as 1615 and began work there.

However, it was not until about fifteen years later, in 1634, that Champlain and the French authorities decided to erect a fortified post at Trois-Rivières, both as protection against the frequent raids of the hostile Iroquois tribes and as a centre for the fur trade and for catholic missionary work.

During the following years, in spite of the continual Iroquois menace, Trois-Rivières became an important entrepôt for the trade with the Indians. But after 1660, the fur commerce in this region declined, partly because of the construction of a post at Tadoussac, at the mouth of the Saguenay river, and partly because of the growing importance of the fortified post of Ville Marie (now Montréal).

During the remainder of the French regime in Canada until 1763, Trois-Rivières continued to be of importance as the administrative centre for a large region of New France.

After the British occupation of Canada in 1763, Trois-Rivières retained its importance as an administrative centre for the surrounding region of Lower Canada. However, it was not until the 1840s that economic progress began through the large Canadian and American lumber companies which exploited the vast forest wealth along the St. Maurice

river. Large lumber mills sprang up along the shores of the river.

At the end of the 1880s, a further economic step was taken when the manufacture of paper from wood-pulp stimulated the growth of the pulp and paper industry all over northern Québec. Large paper mills were built in this city (1). The three mills in Trois-Rivières supply nowadays much of the paper for the printing of newspapers in the great cities of the United States such as New York, Boston and Chicago.

Trois-Rivières is also a centre of textile manufacturing. The following table and map have been produced by the Business and Industrial Development Board (Trois-Rivières) for 1971-72. The table indicates the main industries in Trois-Rivières, their products and the number of people they employ. On the map are located these industries and other places of interest (2).

A certain economic stagnation affects the city at present, e.g. in the textile industry. The pulp and paper industries are also less active because of the diminution of the forests' reserves and growing foreign competition. The population grew by only 9% between 1956 and 1966, one of the lowest rates of the Province. The region has not attracted an important manpower but has rather served to provide other regions with skilled workers. Other factors may explain this situation, namely a lack of an adequate transport system, an ageing industrial structure, lack of investments, the remoteness of raw materials, etc.

(1) The following sources have been used for this short history of Trois-Rivières: A. Tessier, (1935) and Y. Thériault, (1954).

(2) An oral authorization has been given by the Board to reproduce these two documents.

Table 1: Trois-Rivières: Industries (over 200 employees)

Company's Name	Products	Employees
Bell Canada	Telephone Service	325
Canron Limited	Iron Products	703
Canadian International Paper Co.	Newsprint	1,706
Canadian Pacific Railway Co.	Transportation	209
Central Québec Steel Ltd.	Structural steel	200
Consolidated Bathurst Ltd.	Newsprint	1,296
Domtar Newsprint	Newsprint	1,025
Girard & Godin Ltée.	Caskets	200
Ferguson Atlantic Ltd.	Underwear	320
Hydro-Québec	Electricity	481
J.C.Malone Company (1959) Ltd.	Stevedores-Dredgers	500
Reynolds Aluminum	Aluminum products	900
St.Maurice Forest Protective Association Ltd.	Forest Protection	203
St.Maurice River Boom Drive Company Ltd.	Boom & Drive	295
Style Guild Du Cap Corp.	Shirts	200
Three Rivers Shipping Co.Ltd.	Stevedores-Dredgers	203
Tooke Bros.Ltd.	Garment	500
Wabasso Cotton Company Ltd.	Textiles	1,910
Westinghouse Canada Ltd.	Electric Light Bulbs	913

* N.B.- There are over 100 smaller industries employing 3,000 persons.

* Source: Scott's Industrial Directories
City of Cap-de-la-Madeleine
City of Trois-Rivières

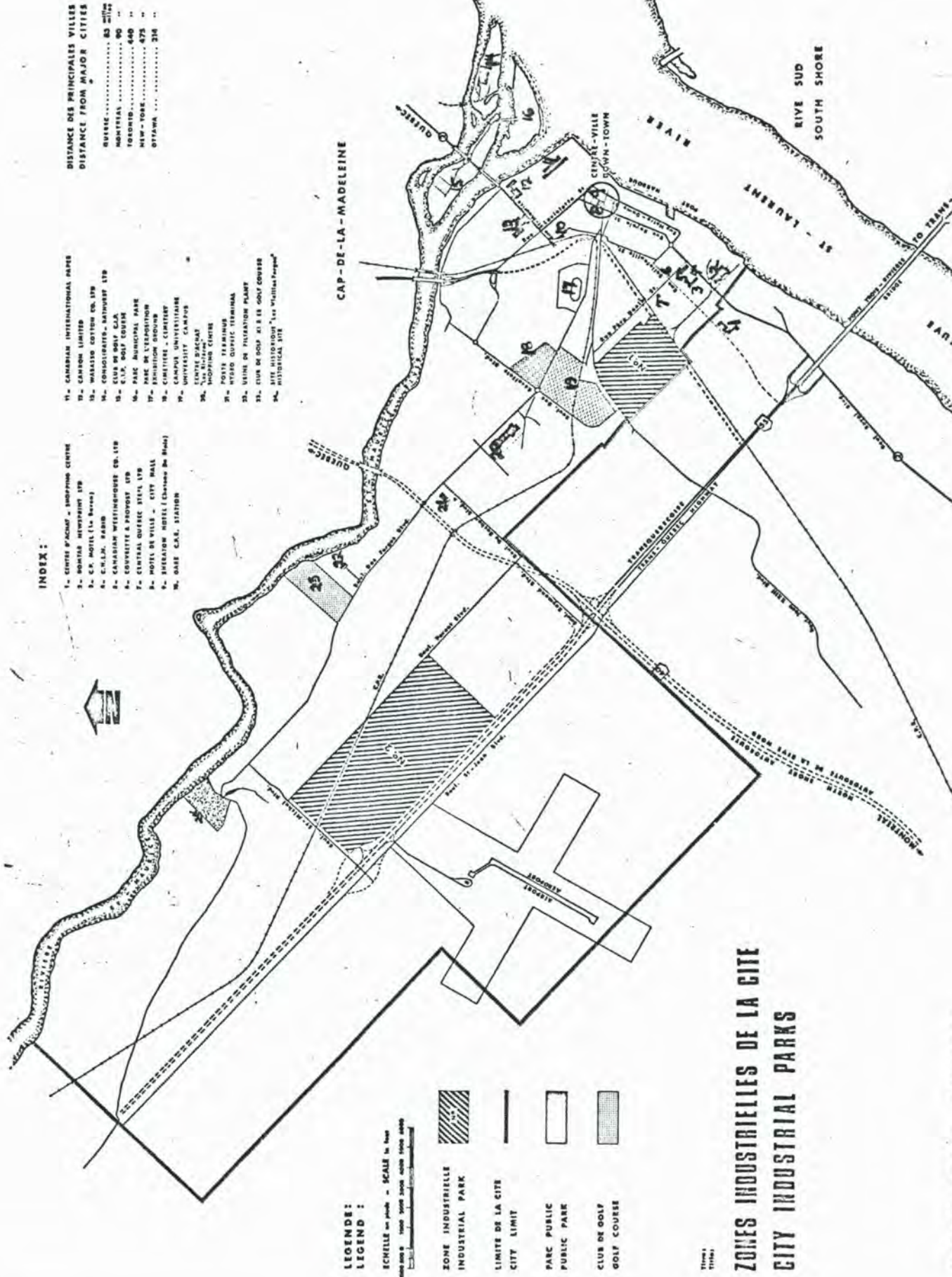

INDEX :

- 1. CENTRE D'ACHAT - SHOPPING CENTRE
- 2. MONTEAU METROPOLITAIN LTD
- 3. C.P. MOTEL (La Borne)
- 4. C.N.L.M. PARC
- 5. CANADIAN WESTINGHOUSE CO. LTD
- 6. COUVETTE & PRODUIT LTD
- 7. CENTRAL QUÉBEC CIVIL LTD
- 8. MOTEL DE VILLE - CITY MALL
- 9. SHERATON HOTEL (Château de Marie)
- 10. GARE C.A.S. STATION
- 11. CANADIAN INTERNATIONAL PARKS
- 12. CANTON LIMITED
- 13. WARRASO COTTON CO. LTD
- 14. CONSIGRATES - MATHEW LTD
- 15. CLUB W BOLD C.L.A.
- 16. C.L.A. GOLF COURSE
- 17. PARC MUNICIPAL PARK
- 18. PARC DE L'ÉROSION
- 19. UNIVERSITÉ DE QUÉBEC
- 20. COMPTON - CANADIAN
- 21. CANADA UNIVERSITAIRE
- 22. UNIVERSITY CAMPUS
- 23. SENTE D'ACHAT
- 24. TON BARRAGE
- 25. SHERATON HOTEL
- 26. MONTEAU METROPOLITAIN
- 27. VILLE DE TILLOTSON PLANT
- 28. CLUB DE GOLF AT 8 DE GOLF COURSE
- 29. SITE HISTORIQUE "Les Vallées Perdues"
- 30. HISTORICAL SITE

DISTANCE DES PRINCIPALES VILLES
DISTANCE FROM MAJOR CITIES

QUÉBEC.....	83 miles
MONTRÉAL.....	90 "
TORONTO.....	440 "
NEW-YORK.....	675 "
OTTAWA.....	316 "

**LEGENDE:
LEGEND :**

ÉCHELLE en pieds - SCALE in feet
1:50,000

- ZONE INDUSTRIELLE INDUSTRIAL PARK
- LIMITE DE LA CITE CITY LIMIT
- PARC PUBLIC PUBLIC PARK
- CLUB DE GOLF GOLF COURSE

**ZONES INDUSTRIELLES DE LA CITE
CITY INDUSTRIAL PARKS**

Map 2: Trois-Rivières: Industrial Parks and main industries.

1.2.2 Some data on the population

The present population of Trois-Rivières consists of 55,869 people: 27,001 men and 28,868 women (1).

The major part of the population is of French ethnic origin and officially adheres to the Catholic church. The following tables give the range of the population by: ethnic group, religious denomination and mother tongue.

Table 2: Population by Ethnic Group:

Total	British	French	Austrian	Chinese	Czech
55,885	2,490	52,600	-----	20	10
	Finnish	German	Hungarian	Italian	Japanese
	-----	155	25	85	-----
	Jewish	Native Indian	Negro	Netherlands	
	30	80	30	5	
	Polish	Russian	Scandinavian	Slovak	
	20	5	45	-----	
	Ukrainian	West Indian	Others and unknown		
	35	10	250		

- (1) The following figures have been taken from the Canada Census of 1971:
 Population by Ethnic Group: Table 5, vol.1, part lll.
 Population by Religious Denomination: Table 13, vol.1, part lll.
 Population by Mother Tongue: Table 21, vol.1, part lll
 Official language and language most often spoken at home: vol.1, part lll.

Table 3: Population by religious denomination

Total	Adventist	Anglican	Baptist	Buddhist and Confucian
55,890	-----	295	175	-----
	Christian and Missionary Alliance			Christian reformed
	-----			5
	Churches of Christ, Disciples			Greek Orthodox
	-----			60
	Jehova's Witnesses	Jewish	Lutheran	Mormon
	100	15	5	5
	Pentecostal	Presbyterian	Roman Catholic	Salvation Army
	-----	25	53,735	25
	Ukrainian Catholic	United Church	Others	No religion
	170	810	45	415

Table 4: Population by Mother tongue:

English	French	Chinese and Japanese	Croatian, Serbian, etc.		
1,890	53,695	20	-----		
Czech and Slovak	Finnish	Gaelic and Welsh	German		
5	-----	10	55		
Greek	Indian and Eskimo	Italian	Magyar	Netherlands	
15	-----	65	5	15	
Polish	Russian	Scandinavian	Ukrainian	Yiddish	others
5	-----	15	5	---	75

Another table taking into account the French and English languages gives the following distribution:

Table 5: Official language and language most often spoken at home:

English only	French only	Both English and French	
585	42,290	12,980	
Neither English or French		Mostly English	Mostly French
25		1,910	53,910

The preceding tables have been included in order to show the distribution of the population of Trois-Rivières according to religion, ethnicity and language. As has been previously said, the great majority of the population is of French origin, has French as its language and belongs to the Roman Catholic Church. These figures are important in that they justify the choice of the informants used in the present research, namely being all French-speaking people of a French origin and also belonging officially to the Roman Catholic Church.

1.2.3 Sampling procedure

In order to obtain as complete as possible a picture of the structure of the phonological segments chosen to be studied as they are spoken by native Trifluvians, three basic dimensions have been taken into account:

1- variation which is determined by the linguistic environment in which the phonemes occur, as in the case of a possible diphthongization of some phonemes, which occur only when in an accented syllable closed by certain consonants and not by others;

2- variation in the speech of any one individual, due to self-monitoring or to any influence of situational factors, such as formality of the occasion, conscious effort of the speaker to present himself in a particular way to the hearer, etc. ;

3- inter-individual variation, due mainly to differences in background such as education, age, peer group influence, etc.

To investigate all these aspects at once presents a task of some difficulty. However, in order to make a general assessment of inter-individual variation, a sample of individuals was used. This sample sought to reflect a range of social characteristics along all the dimensions which could have a direct or indirect influence of the speech of the people.

Because of a lack of time and material, the investigator could not herself make a random sample of the population. Another point is that such a sample had already been done by a team of the Université du Québec in Trois-Rivières in 1972. The "Centre d'Etudes en Loisirs" made a **survey** in Trois-Rivières in order to establish a development plan concerning spare-time activities of the people of this city. They therefore built a questionnaire which was sent to some hundreds people, randomly chosen. The sampling carried out by the "Centre d'Etudes en Loisirs" was able to provide the investigator with all the information concerning the name, address, and place of birth of their informants. Thus, the task remained to select all the names

of those claiming to have been born in Trois-Rivières or to have arrived there by the age of six. Some 160 persons remained out of this first selection.

The goal of such a sampling was to represent the maximal inter-individual variation existing in the French of native Trifluvians, with a minimal number of informants. An average recording of one hour for each informant was desired, but also a total of about eighty hours of recorded speech, since it seemed the maximum the investigator could hope to deal with adequately. Thus, a maximum number of sixty informants was fixed. Given the consistency of speech data (1), it was felt that this sample was large enough to represent the possible variations within the community, if well stratified.

The first sampling consisted of all individuals aged fifteen or over who were both native speakers of French and native Trifluvians. Native Trifluvians were defined as those having been born in Trois-Rivières or having arrived in the town by the age of six, i.e. before primary school.

Quotas were subsequently set up so as to be certain of having equal representation within each subdivision in terms of age, sex, occupation.

Out of the number of sixty fixed, it was decided to have equal sex representation, i.e. thirty men and thirty women. The age was afterwards divided into three categories, namely: 15 to 24 years of age, 25 to 44 years old, and 45 years of age or older. Educational levels were thereafter

(1) cf. section 1.1.6 and Labov (1969a)

established, representing basically the primary, secondary and collegiate levels, i.e. 9 or fewer years attendance at school, between 10 and 12 years of schooling, and finally 13 or more years of education. Occupations were classified into three main categories: professionals (including lawyers, doctors, engineers, managers, etc.) ; white collar workers (i.e. all office employees, clerks, etc.) ; and manual workers (i.e. skilled and unskilled workers). These divisions of the occupations are very gross, but it was impossible to go into further details given the small number of informants.

The quotas fixed for each subdivision are shown in table 6.

		Male	Female	Total
Occupation	age			
Professional	15-24	3	3	6
	25-44	3	3	6
	45 +	4	4	8
				<hr/> 20
White collar worker	15-24	3	3	6
	25-44	3	3	6
	45 +	4	4	8
				<hr/> 20
Manual worker	15-24	3	3	6
	25-44	3	3	6
	45 +	4	4	8
				<hr/> 20
Total		30	30	60

Table 6: Quotas of informants by sex, age and occupation

The subdivision "education" being more delicate to establish during the first contact with the informant, it was decided to add it after the interview was done, thus not taking it into account in the choice of informants. The method seems to have been adequate since the educational level generally fitted very well with the occupation of the informants who were interviewed.

In order to have also a representation of all important areas of the city, the informants were chosen according to their geographical situation. This was a simple task since Trois-Rivières is a city where there is a strong residential segregation according to the social status of individuals.

After having determined the quotas ensuring an equal representation of each subdivision in terms of age, sex, occupation, education and geographical situation, the next task concerned the selection of 60 informants out of the 160 possibilities available from the first selection made with the help of the sampling of the "Centre d'Etudes en Loisirs".

In order to obtain the required number of 60, people were randomly chosen from the available list and were thereafter contacted by the researcher. The reason for the interview was presented as being an interest on "regional accents" rather than on "social accents". People contacted in this way were told that the interview would be fully confidential. The sixty cases or categories were filled up in this manner. It took some hundred and twenty approaches to obtain the required number of 60, sometimes because people refused, sometimes because a particular

category was already full. Six informants were found with the help of some informants who gave names of friends or relatives.

1.2.4 Geographical distribution

The geographical distribution of the sixty people interviewed is shown on map 4 which indicates the dispersal of the sample population throughout the seven socio-demographic areas of the city (1). However, the seven socio-demographic areas of Trois-Rivières will be briefly described (cf. map 3).

1. Parish of Ste.Cécile

The population is the second oldest of the town. It is mainly composed of workers with the lowest salaries and the lowest level of education. The mobility rate is very low. There are more tenants than owners.

2. Parish of the Cathedral.

A population with a high proportion of old people and with also a very low income level. This is the poorest area of Trois-Rivières, but the levels of education and of professional activity are somewhat higher than in Ste.Cécile. There is a large majority of tenants.

(1) Data for the description of these seven socio-demographic areas were obtained with the help of the "Centre d'Etudes en Loisirs" of the Université du Québec, Trois-Rivières.

3. Parishes of Ste.Marguerite and St.Philippe

The population is younger than in the first two sectors. The average income is also somewhat higher. The level of education is very low and they are at the second rank for the tenants' proportion v. owners.

4. Parishes of St.François d'Assise, St.Sacrement, Notre-Dame des Sept Allégresses.

The characteristics noted for the preceding three areas are improved in this area: higher income, higher education, etc.

5. Parishes of St.Jean-de-Brébeuf and Notre-Dame-de-la-Paix.

The population is younger in that there are more young children. The occupations and educational level are higher than in the first four areas.

6. Parishes of St.Jean-Baptiste and St.Pie-X.

This is the richest area, with the youngest population and the highest category of jobs. The average of years of schooling is also the highest with the highest average income and the highest percentage of mobility.

7. Parish of St.Michel des Forges, Ste.Thérèse and the sector Lambert in the parish of Notre-Dame-de-la-Paix.

This is a heterogeneous area. It has a young population and the second highest average of owners. However, the average of years in school is below the general average and the occupations are low or in the middle of the scale.

Map 4: Geographical distribution of respondents within
Trois-Rivières, according to the socio-demographic
areas.



The dots indicate the loca-
tion of each of the sixty
informants.

Except for the last area, Trois-Rivières presents a very significant cartography: the further from the centre one goes, the younger the population and the higher the income. As indicated on map 4, the concentration of dots is about the same for each area except for area three, where only four informants are present. Because of the residential segregation in this town, a choice of informants according to occupations led to an approximately equal geographical distribution as well, if the socio-economic situation of a respondent is compared with the socio-demographic description of the part of the city he lives in.

1.2.5 Occupation and education.

Stratification of the sample was intended to provide occupational and educational distribution among respondents, income pairing usually with the occupational and educational factors. Table 7 indicates the distribution of occupations and educational levels and the number of respondents concentrated in the various socio-demographic areas.

The richest of our informants are mainly concentrated in the 4th, 5th and 6th areas while the poorest of the respondents mainly live in sector 1 and 2 and in a certain area of sector 7. The rest of the informants are dispersed throughout the city.

Table 7: Distribution of respondents by occupation, education, age and socio-demographic areas.

age	occupation	education	socio-demographic areas							Total	
			1	2	3	4	5	6	7		
15-24	Professional	9- 10-12 13+				2	1	3		6	
	White collar worker	9- 10-12 13+	1	1		3		1		6	
	Manual worker	9- 10-12 13+	1						4	6	
25-44	Professional	9- 10-12 13+					1		2	2	6
	White collar worker	9- 10-12 13+		1		2		1	2	6	
	Manual worker	9- 10-12 13+	1			1	2		1	1	6
45 +	Professional	9- 10-12 13+	1	1		2	1	3		8	
	White collar worker	9- 10-12 13+		1		2		3			8
	Manual worker	9- 10-12 13+	3	1	3		1			8	

1.2.6 Place of origin

One of the most important criteria of a potential respondent was that of his having been born in Trois-Rivières, or having lived there from at least age 6. In order to check possible regional dialect influence on respondents' speech, questions were asked about the place of origin of their parents and grandparents. Twenty of them had both father and mother born in Trois-Rivières, fifteen had only one of them born in the city, and twenty-five had neither parents born in Trois-Rivières but mainly in the surrounding villages. It is interesting to note that out of the fifteen informants who had only one parent born in the city, eleven informants had their mother born in Trois-Rivières and four only their father.

In all, thirty-five of the sixty informants had at least one parent born in Trois-Rivières.

1.2.7 Summary

In this section, an attempt has been made to show how respondents were distributed according to the criteria (age, sex, occupation, education, geographical area) set out in the sampling procedure. It is hoped that the method used, though not ideal, was adequate to obtain a random sample and a fair representation of the population.

1.3 Data

1.3.1 Conduct and content of interviews

The interviewer is a native speaker of Québec French and has lived in Trois-Rivières from the age of nine.

The goal of the interviews was to obtain good recordings of speech in as an informal conversation as possible, given the somewhat unnatural circumstance of speaking to a stranger in the presence of a tape recorder. The context of a formal interview normally tends to elicit formal speech. As Labov states: "any style of speech used in a formal interview is biased towards the formal end of the spectrum of behavior"(1). However, without aiming at the most casual form of speech in a formal interview, it is nevertheless possible to elicit distinct styles within the course of the interview, which would go from a careful form of speech to the nearest possible casual style, within the boundaries of this formal setting. The contexts created in order to obtain different stylistic variations will be explained in the following paragraphs. However, it should first be noted that the tape recorder was left running for the whole period the interviewer was in the house, i.e. before and after the period of the interview proper. Interviews were recorded on 5-inch, 600-foot BASF tapes, using a Uher microphone and a Uher 4000 Report L tape recorder.

(1) W.Labov, (1966a), p.87

The interview began with a series of questions regarding background information on the interviewee: age, occupation, schooling, birthplace of parents, etc. (cf. Questionnaire, appendix).

The phonological variables to be studied were arranged, as stated before, so as to occur in different styles within the course of the interview. Three different contexts have therefore been elicited and determined by the type of questions asked and by the place they had in the interview and the degree of psychological tensions imposed by the formal situation on the informant (unknown interviewer, tape recorder, microphone, etc.).

The first context was given by 206 closed questions that the interviewer asked herself and that the informants had to answer by one word (1). The questions were constructed in such a way that the informants had only one alternative response. This had the advantage of having all the studied phonological variables represented in all their possible positions in the syllable and also having these variables pronounced by all informants in the same environments. The first part of the interview had the effect of relaxing the informant because of its play aspect. The informants gradually paid less and less attention to their pronunciation as they entered more into the play-situation and therefore thought more of the correct answer to give than of the pronunciation. This section took between ten to fifteen minutes to complete. The style elicited by this question-answer context will be called "careful", because it occurs at the beginning of the interview, where a certain

(1) cf. Davis and Davis, (1969) and Wells, (1971) for a similar approach

tension is likely to arise, and because of the special situation it creates. Having just one word to say, the informant is likely to pronounce it more carefully and clearly than if this same word were used in a rapid conversation.

The second context was a short story to be read as naturally as possible by the informant. The atmosphere was more relaxed. For some informants though, it became a school-like exercise in which they could be judged on their skills in reading. A much more careful style was elicited from such informants and hesitations often occurred. They were afraid of having a judgment made on their performance. However, after having been told that this part of the interview consisted of a short story which the interviewer wanted to hear without any implication of judgments of any kind, the majority of these informants seemed more relaxed.

Although the atmosphere was more relaxed, most of the informants used a somewhat more careful style than in the first part of the interview. This style is called "reading style" (abbreviation:RS). Everyone showed some hesitations because the text was read for the first time, and all paid a particular attention to pronunciation. This reaction is easily understandable since reading is associated with a similar exercise done at school, where careful performance was paramount, with stress being put on pronunciation and intonation.

This context was included to judge the effects of a formal reading style on informants' phonology, as well as to provide another uniform context for comparing informants with each other.

In the third and last part of the interview, the interviewer tried to encourage the respondent to talk on a variety of subjects, including language. Both interviewer and informant were relaxed. Confidence had been established between both; and the texts, microphone, and tape recorder were forgotten. The style elicited here is called "formal conversation" (abbreviation: FC). It is obviously not the most familiar form of speech, but a natural conversation between two persons who know each other slightly. With all informants the conversation was natural and quite informal, now without apparent tensions and special stress being put on the pronunciation. This section lasted between fifteen to forty minutes according to the informants. This is an important part of the interview where the phonemes studied were to occur in a more informal context, a natural conversation. In this context, it was impossible to have the same words for all informants. The sounds to be studied were taken here within phonetic contexts similar to those found in the first and second parts of the interview. For the vowels in accented positions, only those occurring finally in a rhythmic group, determined by syntax, were considered. Respondents freely discussed their opinions and experiences, although some of them may have tried sometimes to impress the investigator by using more formal speech. This behaviour is however not unusual in other types of interaction, in which a speaker may try to impress an interlocutor by using a more careful style of speech.

The whole of the interview took between forty minutes and one hour and a half. It took three months of full-time work by the investigator to complete the sixty interviews. These interviews were recorded in similar circumstances, i.e. in one, reasonably informal context, namely the informants' homes.

1.3.2 Phonetic transcription

An auditory analysis of the data obtained was made in two steps: a first hearing of each tape without making any notation, followed by three hearings of the tapes using a narrow phonetic transcription of each sound produced. These three hearings were conducted at different periods of time, i.e. a short interval was allowed between each hearing so as to enable a fairer and more accurate transcription. It took seven months of work to complete the transcription of the whole corpus.

Even though French phoneticians like J.D.Gendron use mainly the phonetic alphabet of Rousselot and Gilliéron and think of it as being a more suitable instrument to describe French sounds (1), the International Phonetic Alphabet has been used here because it seemed an adequate system for the purpose of this research and also because of its international usage.

1.3.3 Summary on statistical methodology

The completed analyses dealt with phonetic variations found within the corpus. To these variant forms have been applied quantitative techniques so to arrive at an understanding of the different rules regarding the variations, as well as the social and/or stylistic factors influencing them. The following statistical methodology was applied to

(1) J.D.Gendron, (1966), p.11

the data.

In dealing with categorical data as has been done in this particular research, it is often more beneficial as well as statistically convenient if comparisons in the form of a 2×2 table are considered. For example, the data are presented in the following way with the intention of comparing two groups:

	Sound 1	Sound 2	Total
Group 1	a	b	n_1
(1) Group 2	c	d	n_2
Total	t	$N-t$	N

Each group is seen as representing a particular class of informants. For example, group 1 is composed of males, group 2 is the female group; or group 1 is composed of those informants under 45 years of age and those informants of 45 years and older are in group 2. Since in the present thesis an informant most often responds to sound 1 and 2 and not to one sound only, the group as a whole is taken into consideration and the total number of responses to either sound are apportioned by the frequency of the sound within the group. The letters a, b, c, and d represent the total number of responses by each group. For example "a" is the total number of responses to sound 1 in Group 1. The letter "b" is the total count of sound 2 occurring in Group 1, etc.

The mathematical relationships in the table are:

$$\begin{aligned}
 (2) \quad & a+b = n_1 \\
 & c+d = n_2 \\
 & a+c = t \\
 & b+d = N - t \\
 & n_1 + n_2 = (N-t) + t = N
 \end{aligned}$$

P_1 is defined as the proportion of responses to sound 1 in group 1. $1 - P_1$ is the proportion of responses to sound 2 in group 1. P_1 is estimated by a/n_1 . Likewise P_2 is the proportion of responses to sound 1 in group 2. the estimate of P_2 is c/n_2 . Ultimately the interest is in the null hypothesis, i.e. H_0 , that $P_1 = P_2$, or the hypothesis assuming that there are no differences between group 1 and group 2. The null hypothesis is usually written:

$$(3) \quad H_0 : P_1 = P_2$$

This null hypothesis is tested in one of two ways. First of all if the sample size is large enough, the traditional Chi Square statistic on 1 degree of freedom could be computed, which is:

$$(4) \quad \chi^2(i) = \frac{N \left\{ \frac{ad - bc}{n_1 n_2 t (N-t)} \right\}^2}{n_1 n_2 t (N-t)}$$

If $\chi^2(i) > 3.84$, then for those who adopt the traditional point of view, the data are said to be significant at the 5% level and H_0 is rejected in favour of the alternative

hypothesis:

$$(5) \quad H_0^1 : P_1 \neq P_2$$

The second way to test H_0 is to suppose that the number of responses in each group are from a binomial distribution. It is assumed that the probability of a response to sound 1 in a single trial in group i ($i = 1, 2$) is P_i . Thus, the probability of "a" responses to sound 1 in group 1 is written as:

$$(6) \quad \Pr \{A=a / \text{Group 1}\} = \binom{n_1}{a} P_1^a (1 - P_1)^{n_1 - a} \\ a = 0, 1, 2, \dots, n_1$$

Similarly

$$(7) \quad \Pr \{C=c / \text{Group 2}\} = \binom{n_2}{c} P_2^c (1 - P_2)^{n_2 - c} \\ c = 0, 1, 2, \dots, n_2$$

To test the null hypothesis, the Fisher exact test is performed. This test serves to note the total number of responses (in both groups) to sound 1, $t = A + C$, but in order to see the differential effects between P_1 and P_2 , the distribution of A in (b) conditional on $t = A + C$ is considered, i.e.

$$(8) \quad \Pr \{A=a / T=t\}$$

Consider the hypothesis H_0 being true, then:

$$(9) \quad \Pr \left\{ A=a / T=t \text{ and } P_1 = P_2 \right\}_{H_0} = \frac{\binom{n_2}{c^2} \binom{n_1}{a^1}}{\binom{N}{t}}$$

$$0 \leq a \leq \text{minimum } (n_1, t)$$

The probability given by (9) is the point probability associated with the hypergeometric distribution. Its value is the probability of obtaining "a" responses to sound 1 in group 1 given that the marginal total, T, is fixed and the null hypothesis that $P_1 = P_2$.

Often this exact value given in (9) and the $\chi^2(t)$ value will compare quite favourably. However, in small sample sizes, because of the underlying assumptions behind the $\chi^2(t)$ statistic, one might be willing to put more credence in the exact value. One might interpret a high value of (9), i.e. close to one, as there being no strong evidence against H_0 . A low value of (9) indicates strong evidence against H_0 .

The methods put forth here are two possibilities which can be considered when comparing two groups. They are not exhaustive.

If it appears desirable to look at the data otherwise, i.e. without relying on some of the statistical methodology alone, then attention should be focused on the values given by P_1 and P_2 . P_1 and P_2 were defined in the third paragraph of this section. Clearly a large absolute

difference between the two values of the order .4 to .99 would seem to indicate a difference in the proportion of responses to a particular sound between the two groups. It may be unclear that a difference exists if $P_1 - P_2$ is of the order .3 and perhaps there is no difference between the two proportional responses if there is an absolute difference of .1 to .2. These numbers are just arbitrary reference points. A reader may have his own ideas as to which values between 0 and .99 would indicate a certain level of difference. There are other methods available to us in assessing whether or not the proportional responses are very different. For example, the ratio of P_1 to P_2 could be considered, or any other common sense methodology could be employed, which will give the reader some feeling for the order of magnitude of difference which may exist for a particular response between two groups.

$$\begin{aligned}
 P_1/P_2 > 1 &\Rightarrow \hat{P}_1 > \hat{P}_2 && \text{(e.g. 2 and above)} \\
 P_1/P_2 < 1 &\Rightarrow \hat{P}_1 < \hat{P}_2 && \text{(e.g. close to 0)} \\
 P_1/P_2 = 1 &\Rightarrow \hat{P}_1 = \hat{P}_2 && \text{(near 1)}
 \end{aligned}$$

A value ratio of the ratio much greater than one or from .5 to 0 would indicate a large difference between the proportional responses. Any value close to 1 would make it unclear whether or not any difference exists and might even favour the belief that no difference exists at all (1).

(1) This section on statistical methodology has been written with the help of Mr. Al Bartolucci.

1.3.4 Summary

These last sections have sought to provide details of the methodological aspects involved in the present study of Trois-Rivières French, particularly as regards the techniques of collecting, handling and analysis of data.

Such quantitative methods are indispensable for an understanding of the complex relationships between people and the way they use language, because, generally, these relationships are discernible only in quantitative terms.

Chapter 2

Study of the co-variation of phonological and
sociological variables.

2.0 Scope of the study

The scope of the present study aims at arriving at a better understanding of the varieties found within a speech community in order to enlarge the field of what is at present known on Québec French language and the multiple factors embedded in the causes of any linguistic diversity present in a community. This study does not however claim to be exhaustive, since all aspects of the language could not be taken into consideration. Its main interest focuses on some aspects of Trois-Rivières French phonology, leaving out all that concerns grammar, semantics, etc. The analysis is synchronic with only occasional historical notes.

Most studies on Québec French phonology have dealt with a comparison between Standard French and Québec French, with a definite prescriptive and ameliorative perspective. Gendron for example, and the "Société du Parler Français au Canada" view French as spoken by some people as rural and popular, a form of language which the elite has to bring up to a higher level. As Gendron states:

"...il est apparu la nécessité pratique, sinon un désir légitime, d'élever le français canadien à un échelon supérieur au parler populaire, d'affiner non seulement la langue écrite, littéraire, mais aussi la langue parlée, et d'aligner sa prononciation sur celle du français général. (...) Mais dans les milieux cultivés canadiens, il y a encore, malgré tout, beaucoup à faire pour affiner la prononciation soutenue, et l'effort entrepris dans ce sens ne devra être ni relâché ni ralenti " (1).

(1) J.D.Gendron, (1966), p.160

Public advertising reinforces this point of view in informing people that "Bien parler c'est se respecter" (to speak well is to have self respect) and in urging them to "Bien parler pour être bien compris" (speak well to be properly understood). This leads to a certain alienation where two varieties of French are depicted: "good" speech, approximating to an international Standard French, and for some even approximating to the Parisian norm; and "poor" French, associated with qualifications such as uneducated, lower-class, rural, etc.

The aim of the present study is not concerned with such points of view in that it considers special aspects found in the phonology not as errors or anomalies, but as part of a coherent system shared by all members of the community, any speech variation being part of a complex but systematic sociolinguistic structure (1).

In dealing with urban dialectology, heterogeneity in the speech of a population is obviously encountered. This heterogeneity is by no means negative. On the contrary, it reveals an undeniable social reality. And it is exactly the purpose of this study which is stressed through the aspect of heterogeneity, namely the extent of the correlation between and co-variation of linguistic and sociological parameters.

The most interesting linguistic features to be studied in such a perspective are those which are "high in frequency, have a certain immunity from conscious suppression, are integral units of larger structures, and may be easily quantified on a linear scale" (2). Phonological features are

- (1) See for similar point of view: G.Sankoff & D.Sankoff, (1971), pp. 4-5 and E.Brent, (1971), p.3
 (2) W.Labov, (1966a), p.49

those which fulfil these requirements most readily. A single structural unit, the phoneme, may be realized by means of different sounds; and what may seem at first sight to be inconsistencies in the speech of one individual, may, when distributed within the community, become part of a coherent and consistent structure. In this study, therefore, some aspects of the sound system of Trois-Rivières French will be considered, with the intention of investigating and drawing conclusions from the co-variation of phonological features with sociological parameters. Seven phonological variables (1) will be given particular consideration. These variables can be said to consist of the different pronunciations of each segment in a particular set of linguistic environments where this segment can be found.

2.1 Phonemic inventory of Trois-Rivières French

Before dealing in more detail with the seven phonological variables investigated in this study, the 36 phonemes of Trois-Rivières French will be described.

In terms of an articulatory type of classification, Trois-Rivières French phonemes belong to one or more of the articulatory classes described below:

- | | |
|--------------------|-----------------|
| I. Plosives (P) | IV. Lateral (L) |
| II. Fricatives (F) | V. Trill (T) |
| III. Nasals (N) | VI. Glides (G) |

(1) By phonological variable is meant: a phonological segment which can be involved in co-variation with sociological features and other linguistic variables.

These six classes comprise the consonants of the phonological system and may again be classified into the following classes:

Vll. Bilabial (bl)	Xl. Palatal (pl)
Vlll. Labiodental (ld)	Xll. Velar (vl)
lX. Dental and alveolar (da)	Xlll. Glottal (gt)
X. Palato-alveolar (pa)	XlV. Distinctively voiced segments (voi)

(1)

In *Trois-Rivières* French, as in other languages, the members of N,L,T,G and the vowels, which will be described below, are voiced by definition and devoiced only in particular linguistic environments.

The syllabic segments of the phonological system are distinguished from the above classes and fall in the following sets:

1. Unrounded front vowels (F)
2. Back vowels (B)
3. Distinctively rounded vowels (R)

Members of (R) are front vowels by definition whereas members of (B) are implicitly rounded. A further classification

(1) This articulatory classification is based on the model of E. Brent, (1971). However, changes in the terminology have been made. For example, Brent uses the words "stops, spirants", etc., whereas here, the IPA's terminology has been used, i.e. plosives, fricatives, etc. In addition, there are more precise indications of actual articulation of the sounds, so that instead of classifying /p/, /f/, etc. only as labials, the bilabial and labiodental distinctions have been introduced. Finally, the notation of phonemes follows that used in the IPA.

of the above three sets leads additionally to the following:

4. Nasal vowels (ns)
5. Close vowels (cl)
6. Half-close vowels (hcl)
7. Half-open vowels (hop)
8. Open vowels (op)

The following table summarizes the classification of Trois-Rivières French phonemes in terms of articulatory classes:

		<u>CONSONANTS</u>						
		(bl)	(ld)	(da)	(pa)	(pl)	(vl)	(gt)
P		p		t			k	
P(voi)		b		d			g	
F			f	s	ʃ			h
F(voi)			v	z	ʒ			
N(voi)		m		n			ɲ	
L(voi)				l				
T(voi)				r				
G		w, ɥ				j		

		<u>VOWELS</u>					
		F	Fns	R	Rns	B	Bns
cl		i		y		u	
hcl		e		ø		o	
hop		ɛ	ẽ	œ	œ̃	ɔ	ɔ̃
op		a	ã			a	

Table 8a: Trois-Rivières French phonemes according to an articulatory phonetic classification.

Another description of the phonological system of Trois-Rivières French in terms of binary distinctive phonetic features will be given in order to account for the articulatory parameters shared by consonants and vowels, such as tongue height shared by /g/ and /u/. In this description, a feature present in a phoneme will be entered with a + value and conversely its absence will be indicated by a - value. If a feature is redundant, it will be put in parentheses. Some allophonic variations will be included in the table in the form of alternative feature specifications inclosed in angle brackets: < >. These variations affect the phonemes / t d s z k g ʃ ʒ l r j i y u/ (1). This classification of Trois-Rivières French phonemes is shown in table 8b.

The phoneme inventory described above for Trois-Rivières French differs only in detail from a similar one which may be made for Standard French. There is no difference in number and basic characteristics of phonemes, nor is there any in the articulatory classes in which the phonemes occur. However, there are differences between Trois-Rivières French and Standard French and these concern mainly the phonetic realizations of some phonemes. In this study, there will be no attempt to compare them systematically although some references will be made to Standard French.

In order to study the variation existing in the Trifluvian speech community, seven phonological variables have been chosen on the grounds of the apparent social

(1) This classification of phonemes in terms of binary distinctive phonetic features has been borrowed from E. Brent, (1971), pp.21-22. The only change brought to Brent's table concerns the notation of phonemes. For example, Brent notes the two palato-alveolar fricatives as ξ and ζ , whereas here, the IPA notation is used, i.e. \int and $\ʒ$.

	p	b	f	v	m	t	d	s	z	n	k	g	ʃ	ʒ	ʒ	ɹ	h
Sonorant	-	-	-	-	+	-	-	-	-	+	-	-	-	-	-	+	+
Syllabic	-	-	-	-	-	-	-	-	-	-	-	-	-	-	-	+	-
Consonantal	+	+	+	+	+	+	+	+	+	+	+	+	+	+	+	+	-
Coronal	-	-	-	-	-	+	+	+	+	+	-	-	+	+	+	+	-
Anterior	+	+	+	+	+	+	+	+	+	+	+	+	+	+	+	+	-
High	(-)	(-)	(-)	(-)	(-)	(-)	(-)	(-)	(-)	(-)	(-)	(-)	(-)	(-)	(-)	(-)	(-)
Low	(-)	(-)	(-)	(-)	(-)	(-)	(-)	(-)	(-)	(-)	(-)	(-)	(-)	(-)	(-)	(-)	(-)
Back	(-)	(-)	(-)	(-)	(-)	(-)	(-)	(-)	(-)	(-)	(-)	(-)	(-)	(-)	(-)	(-)	(-)
Rounded	(-)	(-)	(-)	(-)	(-)	(-)	(-)	(-)	(-)	(-)	(-)	(-)	(-)	(-)	(-)	(-)	(-)
Distributed	+	+	(-)	(-)	+	(-)	(-)	(-)	(-)	(-)	(-)	(-)	(-)	(-)	(-)	(-)	(-)
Nasal	(-)	(-)	(-)	(-)	+	(-)	(-)	(-)	(-)	(-)	(-)	(-)	(-)	(-)	(-)	(-)	(-)
Lateral	(-)	(-)	(-)	(-)	(-)	(-)	(-)	(-)	(-)	(-)	(-)	(-)	(-)	(-)	(-)	(-)	(-)
Continuant	-	-	+	+	-	-	-	+	+	-	-	-	+	+	+	+	(+)
Delayed	(-)	(-)	(-)	(-)	(-)	(-)	(-)	(-)	(-)	(-)	(-)	(-)	(-)	(-)	(-)	(-)	(-)
Tense	(-)	(-)	(-)	(-)	(-)	(-)	(-)	(-)	(-)	(-)	(-)	(-)	(-)	(-)	(-)	(-)	(-)
Voiced	(-)	+	(-)	+	(+)	(-)	+	(-)	+	(+)	(-)	+	(-)	+	(+)	(+)	(-)
Strident	(-)	(-)	(+)	(+)	(-)	(-)	(-)	(+)	(+)	(-)	(-)	(-)	(+)	(+)	(-)	(-)	(-)

	j	ç	w	i	y	u	e	ø	o	ε	œ	ɔ	a	ɑ	ɛ̃	œ̃	ɔ̃	ã
Sonorant	+	+	+	+	+	+	+	+	+	+	+	+	+	+	+	+	+	+
Syllabic	-	-	-	+	+	+	+	+	+	+	+	+	+	+	+	+	+	+
Consonantal	<+>	-	-	-	-	-	-	-	-	-	-	-	-	-	-	-	-	-
Coronal	(-)	(-)	(-)	(-)	(-)	(-)	(-)	(-)	(-)	(-)	(-)	(-)	(-)	(-)	(-)	(-)	(-)	(-)
Anterior	(-)	(-)	(-)	(-)	(-)	(-)	(-)	(-)	(-)	(-)	(-)	(-)	(-)	(-)	(-)	(-)	(-)	(-)
High	+	+	+	+	+	+	-	-	-	-	-	-	-	-	-	-	-	-
Low	-	-	-	-	-	-	-	-	-	-	-	-	-	-	-	-	-	-
Back	-	-	+	-	-	+	-	-	-	-	-	+	-	+	-	-	+	<+>
Rounded	-	+	+	-	+	+	(-)	+	(+)	(-)	+	(+)	(-)	+	(-)	+	(+)	<+>
Distributed	(-)	(-)	(-)	(-)	(-)	(-)	(-)	(-)	(-)	(-)	(-)	(-)	(-)	(-)	(-)	(-)	(-)	(-)
Nasal	(-)	(-)	(-)	(-)	(-)	(-)	-	-	-	-	-	-	-	(-)	+	+	+	+
Lateral	(-)	(-)	(-)	(-)	(-)	(-)	(-)	(-)	(-)	(-)	(-)	(-)	(-)	(-)	(-)	(-)	(-)	(-)
Continuant	<+>	(+)	(+)	(+)	(+)	(+)	(+)	(+)	(+)	(+)	(+)	(+)	(+)	(+)	(+)	(+)	(+)	(+)
Delayed	(-)	(-)	(-)	(-)	(-)	(-)	(-)	(-)	(-)	(-)	(-)	(-)	(-)	(-)	(-)	(-)	(-)	(-)
Tense	(+)	(+)	(+)	<+>	<+>	<+>	+	+	+	-	-	-	(-)	(-)	+	-	-	-
Voiced	(*)	(+)	(+)	<+>	<+>	<+>	(+)	(+)	(+)	(+)	(+)	(+)	(+)	(+)	(+)	(+)	(+)	(+)
Strident	(-)	(-)	(-)	(-)	(-)	(-)	(-)	(-)	(-)	(-)	(-)	(-)	(-)	(-)	(-)	(-)	(-)	(-)

Table 8b: Trois-Rivières French phonemes according to a Binary Distinctive Phonetic Features Classification. Value specifications in parentheses are redundant. Angle brackets < > inclose alternative specifications peculiar to certain allophones only.

significance attached to the pronunciation of these segments and of the phonetic differentiation involved. Selection was made on the basis of native knowledge of the speech under investigation and of studies on Québec French phonology, specially those of Gendron (1966) and Brent (1971).

The consonantal phonological variables concern the phonemes /ʃ/, /ʒ/ and /r/, whereas the vocalic segments studied are /ɑ/, /ɛ/, /œ/ and /ɔ/. These seven phonological segments have been described in general terms above, together with the other segments of Trois-Rivières French phonological system. However, no account of the possible phonetic realizations these seven segments might undergo has yet been taken. Thus, the task of the following sections will be to consider these latter in detail, using quantifiable methods in order to discover any co-variation with sociological factors, and in order to establish a theoretical framework for the description of all forms of speech found within the Trifluvian speech community.

In the case of the consonantal variables, as will be seen later, variant pronunciations occur which are usually auditorily quite distinct. This is not the case with the vocalic variables, in that, for a phoneme, a wide range of possible pronunciations along the appropriate phonetic continuum may be encountered, so that, on a purely auditory basis, difficulties arise in determining them. Therefore, for the present purpose, cardinal vowels will be used as a guideline and only those phonetic differentiations perceptible without difficulty will be taken into account. To illustrate this point, the variable (o) will be taken (1).

(1) The phonological variables will be symbolized by enclosure in parentheses. The use of parentheses was made by Labov, (1966a), Trudgill, (1974), etc.

When this vocalic segment is in a final position closed by /r/, the area of pronunciation may be: [ɔ: ɔ̃: ɔ̃:
ɔ̃: ɔ̃: ɔ̃: ɔ̃: ɔ̃:^v ɔ̃:^v.....] , etc. The range is wide, but there are articulations which are clearly distinct from others , namely [ɔ̃:], [ɔ̃:], [ɔ̃:^v], therefore leaving three main features:

- 1- pronunciation near cardinal 6;
- 2- the very open variety;
- 3- the diphthongization of the segment.

It is in this sense that easily perceptible phonetic differentiation is defined. This method of regrouping sound into areas which are clearly distinct will be used for the treatment of each vocalic variable.

The phonological variables will now be described in more detail.

2.1.1 The variable (a)

This variable is concerned with the realization of the open back unrounded vowel, i.e. /a /, where it occurs in a preconsonantal position, as in avril, gâteau, repassage, etc., in a final position checked by a consonant, as in tard, taille, âge, gagne, etc., in a final free syllable, as in bras, chocolat, mois, etc., and finally when it is preceded in any position by the glide /w/.

Back /a/ may be realized, as accounted for in many studies (1), as a half-open rounded back [ɔ̃] , [ɑ̃] therefore becoming

+round
-open

 . This realization may alternate in

(1) cf. J.D.Gendron,(1966); E.Brent,(1971); P.R.Léon and M. Nemni, (1967); A.Ibbotson,(1968); H.Opitz,(1968); etc.

all positions with an open back [ɑ]. Added to this possible realization, [ɑ] may also be diphthongized when found in a final position closed by a consonant. Thus, in a word like taille, either [ta:j], [tɔ:j], or [ta^u:j] can be expected. In the remaining environments, as in repassage, bras, etc., two possible sets of pronunciations can be found, i.e. [rapɑ'sa:ʒ - rapɑ'sa:ʒ] or [rapɔ'sa:ʒ - rapɔ'sa:ʒ]; [brɑ - bra] [brɔ - brɔ]. Thus, the interesting features to be considered will be those of the backing and rounding of [ɑ] and of its diphthongization. The study of alternation between [ɑ] and [ɔ] will be referred to as variable (a)-1.

Other possible realizations of /a/ occur when the phoneme is preceded by the semi-vowel /w/. This vowel may be realized as [ɛ] or [e], thus giving in words like soixante, bouilloire, je bois, the following possibilities: [swesɑ:t - swesɑ:t], [bujwɑ:r - bujwɛ:r - bujwe:r] [bwa - bwe] (1). /a/ becoming $\begin{bmatrix} \text{-open} \\ \text{-back} \end{bmatrix}$, i.e. /a/ going to [ɛ] or [e], is a feature considered as old-fashioned. In fact, this pronunciation was maintained in general French until the 18th century, and even until the end of the 19th century in the Northern provinces of France. It is still used in Trois-Rivières French, although not generally, as will be seen in section 2.3

In short, what will be under special investigation in the study of this phoneme will be the following pronunciations

- (1) Note that the pronunciation [wɛ, we] in a final free position does not affect all lexical items. In the words trois, mois, bois (wood), the only possible variation is [ɑ - ɔ]. No occurrences of [e] or [ɛ] are possible. Thus, lexical items are differentiated in this case from pronouns and verbs:
- je bois, moi → [ʒɑ bwa - mwɑ] can co-vary with [ʒɑ bwe, mwɛ]
but
- du bois, mois → [dy bwa - mwɑ] can co-vary with [dy bwɔ, mwɔ]

[a(:) - ɔ(:) - a^v:] [wa(:) - we(:)] , their interrelation, and their co-variation with sociological parameters.

In order to visualize the main phonetic realizations variable (a) may undergo, a phonetic trapezium will be given, showing the main areas in which distinct pronunciations can fall. On this trapezium, not all realizations can be displayed, since it would be too confusing. Indeed, the realization of the phoneme may be more or less centralized, more or less advanced or backed, etc. Therefore, only the clearly identifiable distinctions will be displayed, i.e. those considered in the study of this variable. The same procedure will apply to the other vocalic variables (cf. end of section 2.1 on variable (o)).

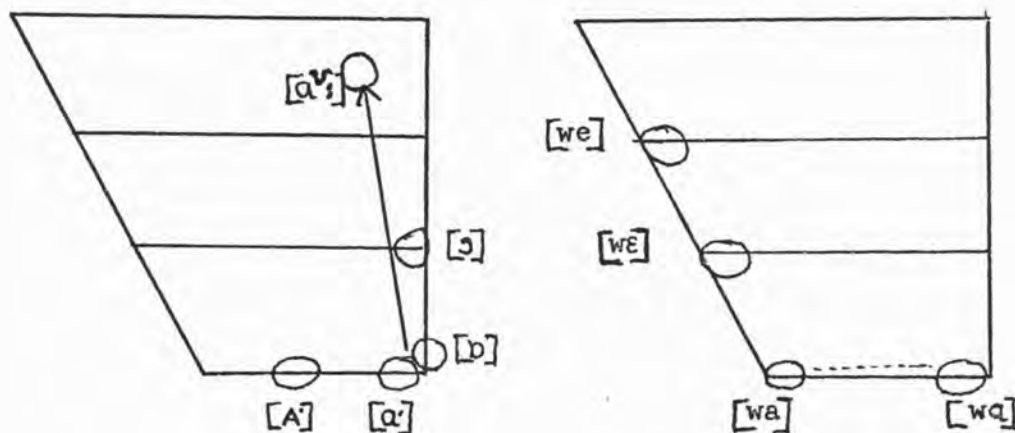

2.1.2 The variable (è)

This vocalic element will be specially studied as it occurs in a preconsonantal position before /r/ as in mercredi, dernière, bercer, in a final position closed by a lengthening consonant or when long historically as in tête, père, and in a final free syllable, as in lait, paix, etc.

In a preconsonantal position where in the sequence / ϵ + r + C /, and in a final free syllable, this phoneme may be realized as a more open segment with less lip action, here referred to as [æ]. This feature is, like the use of [wɛ̃, wɛ] instead of [wa], referred to as archaic pronunciation. This realization of [ɛ] into [æ] was definitely excluded from Parisian French in the middle of the 17th century. Gendron adds that "elle est aujourd'hui complètement rejetée, comme vulgaire, par la bonne société" (1). This is exactly what will be investigated, i.e. how widely this realization of the half-open front unrounded / ϵ / is still used and how this use is represented in various groups of the population.

In a final position closed by a consonant, / ϵ / can be diphthongized when it is long, mainly by the opening of the first segment into [ɛ̃, æ], thus giving pronunciations going from [ɛ̃^l: — ɛ̃^e:] to [æ^l:]. Also, when / ϵ / is followed by /r/, thus giving the sequence / ϵ + r/ʃ this phoneme might have another realization, namely that of closing into an [e:] . This would give [pe:r] instead of the more common [pɛ̃:r] , père .

(1) J.D.Gendron, (1966), p.67

Briefly stated, /ɛ / will be of interest here, when co-alternation of [ɛ] and [æ] is considered, as well as those features of diphthongization and closing, as they might occur in the environments previously described. The following trapezium indicates where these different pronunciations will be found.

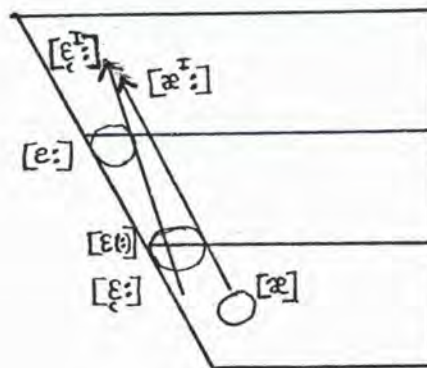

2.1.3 The variables (o) and (eu)

These two half-open segments will be studied mainly in a final position when closed by a lengthening consonant, especially /r/. In this environment, as for (a) and (è), the two vowels can be diphthongized, usually by means of opening the first segment. Thus, the following pronunciations in words like corps and coeur can be expected, i.e. [kɔ:r - kɔ̃^u:r] [kœ:r - kœ̃^y:r]. In addition, these two vowels may be realized as much more open and less labialized, thus giving pronunciations described here as [ɔ:] and [ʌ:] .

Therefore, the opening of both segments, their diphthongization, together with a pronunciation nearer the cardinal vowels will be considered. These different realizations are displayed on the following trapezium.

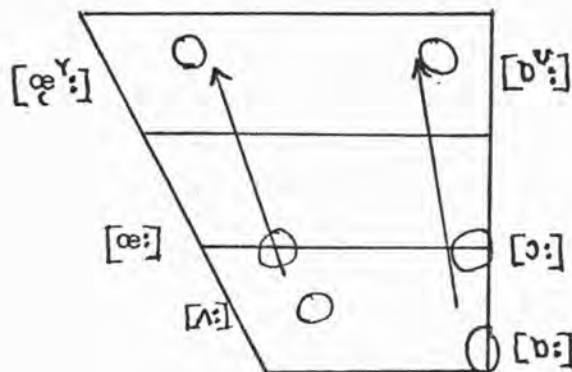

2.1.4 The variables (g) and (ch)

These two palato-alveolar fricatives might undergo a process of velarization, or of glottalization for the phoneme /ʒ/, when initial in a word, in a medial position between two vowels and in a final position. Thus $[\# \overset{3}{\} -$, $-V \overset{3}{\} V-$, $-\overset{3}{\} \#]$ may be realized as $[\gamma \text{ or } \text{h}]$ and $[x]$. As Juneau states: "Pour ce qui est de l'articulation d'"une sorte de h" issue des chuintantes ϵ et j , elle vient selon toute vraisemblance d'une aire comprenant le Sud du Poitou, la Saintonge, l'Angoumois et le Nord de la Gironde" (1) .

(1) M. Juneau, (1972), p.146

In addition, J.D.Gendron notes this type of pronunciation for four of his informants and adds: "Il s'agit d'une prononciation populaire, qui se localise dans une aire linguistique assez restreinte du parler canadien" (1). The present investigation will deal with the incidence of these varieties within the community.

2.1.5 The variable (r)

In general, two realizations of the trill are found in Québec French, namely the alveolar and uvular ones. The distribution of these two varieties in Trois-Rivières French will be studied in order to identify the social implications of such varieties. Gendron (2) states that the uvular trill is found in the region of Québec City, whereas the alveolar one is mainly used in the region of Montréal. It is interesting to note that Trois-Rivières is situated half-way between these two main cities, thus lying midway between these two centres of influence. It will therefore be of interest to try to discover by which of these centres the population is more influenced.

Another interesting phenomenon which affects /r/ is that of its possible deletion when it is found between a vowel and a consonant, as in mercredi, faire comprendre, etc., after word-final vocalism and consonantism, etc.

(1) J.D.Gendron, (1966), pp.135-36

(2) Id., p.135

The phonological constraints operating for r-deletion will be described in more detail in section 2.6.2.1 ; but for the time being, it is worth noting that the following rules may apply for /r/, i.e.

- (1) /r/ → [r]
- (2) /r/ → [R]
- (3) [r, R] → ∅

Juneau gives interesting historical notes about the deletion of /r/ (1). He notes that, in a final position, no r was pronounced in French from the 13th century up to the 17th century. He also remarks that r-deletion in a final position is widely attested from the beginning of the settlement of French people in Québec (2). It originated from the popular speech of l'Île de France of the 17th and 18th centuries, and also from the North-Western and Western provinces as well as those of the Centre. However, it seems that this feature mainly affected nouns ending in -cir and in -eur. When the present study is however considered, other environments seem to have been, or are, equally affected. The specific environments favouring r-deletion will be examined in section 2.6.2.1.

Thus far, the seven phonological variables have been briefly presented. The following sections will be devoted to the treatment of these variables in terms of frequency of occurrence so to arrive at a description of their relationship with sociological factors. As seen in the previous pages, the elements of language under study

(1) M. Juneau, (1972), p.164

(2) Id., p.170

may have two or more surface realizations. These latter may not be completely determined by the environmental constraints only. They may be closely related to such factors as style, education, sex, etc. It is this constraint of stylistic and social factors upon variations found within the realization of the phonological segments which will be considered by statistical methods, and also to what varying degrees they are in co-variation with the linguistic phenomenon.

2.2 Variable (a)-1 and the sociological variables.

The open back unrounded /ɑ/ is used as opposed to open front unrounded /a/ in all positions in the syllable. A back /ɑ/ is used in a final free syllable in words ending in -as, -at, -a, and in some words ending in -ois. The words used in the first part of the questionnaire to represent the area where /ɑ/ will arise are: bras, repas, bas, pas, chocolat, rat, chat, cinéma, Canada, là, trois, mois, bois. The open back unrounded phoneme also occurs in a final closed syllable in various environments. It is used when followed by a lengthening consonant, i.e. /r,v(r),z,ʒ/. In addition, this phoneme is used when it is followed by /j/, by a nasal, and by /s/: thus, in words like tard, base, gagne, réclame, baille, basse, etc., a long back /ɑ/ is expected. With the spelling -afle (as in érafle), -adre (as in cadre), a back /ɑ/ is used. In words ending in -able, a long back unrounded /ɑ/ will be found in words like accable, sable, fable, etc., but a short open front /a/ will rather be expected in aimable, affable, agréable, etc. Finally, when written with a circumflex accent, /ɑ/ is used, so that the opposition /a/-/ɑ/, as in patte-pâte, is maintained. Use of an open back unrounded phoneme as opposed to a front one is therefore phonetically as well as lexically determined.

Brent, Gendron, Léon and Nemni, Juneau, etc. (1) recognize the use of an open back unrounded vowel in these environments. One feature they take into account is the length feature. In a final closed syllable, for example,

(1) E. Brent, (1971), p.39; J.D. Gendron, (1966), p.81; P.R. Léon and M. Nemni, (1967), p.33; M. Juneau, (1972), p.51.

the use of a back /ɑ/, as opposed to a front /a/, is associated with the length of the vowel. The longer the vowel is, the more retracted its articulation will be, and the shorter it is, the more it will be realized in a front position. Length has therefore an effect on the quality of the vowel.

No acoustic tests have been carried out on this particular feature in the present study. However, Gendron, in his study (1966), succeeded in establishing a relationship between length and quality for this particular phoneme. Since, however, no such measurements have been made in this study, the length feature will not be given special treatment. Thus, when it is referred to, it must be remembered that it is based on auditory judgments.

Nevertheless, studies previously done confirm what has been mentioned above, namely that an open back unrounded phoneme is used in a final closed syllable in the environments favouring the use of a long segment. The words tard, gare, âne, gagne, réclame, condamne, âme, taille, baille, tasse, basse, as, pâte, pâte were used in the first part of the questionnaire to investigate the realizations of the open back unrounded phoneme. The latter is also found in a non-final position:

- 1- when it is written with a circumflex accent as in mâchoire, gâteau, etc. ;
- 2- when in a final closed syllable, a posterior /ɑ/ is used, the same phoneme occurring in derived forms when in a non-final syllable, as in repassage, accabler, gagner, etc.;
- 3- and finally in words like avril and mardi.

Different surface realizations may occur in these environments along the phonetic continuum. These may range

from a less back unrounded open segment [A] to a half-open back rounded one [ɔ̃]. To study all the possible realizations of /a/ would be irrelevant and also dubious in that many of these surface realizations are not easily perceptible auditorily. The feature which will remain relevant for the present purpose will be that of the alternation of an open back unrounded realization and of an open or half-open back rounded one, i.e. the backing and rounding of the phoneme /a/. In the case of /a/ in a final closed syllable, another surface realization will appear, namely the diphthongization of long /a/. A study of this possible diphthongization will be made in section 2.4.3 in order to compare it with diphthongizations of other variables, namely (è), (o) and (eu).

The present section will therefore deal with the alternation of [a] and [ɔ̃] in the three positions in the syllable, taking into account the independent variables education, occupation, sex, age and style. The use of what phoneticians often call a dark back [a̠], i.e. [ɔ̃], when referring to realizations of /a/, is a common feature of general Québec French. All studies on Québec French phonology indicate this fact, and the use of [ɔ̃] instead of [a̠] is often mentioned in Archives (cf. M. Juneau, (1972)). At present, little is known about the use a population may make of these different realizations.

In order to investigate the possible correlation of the two variants [a], [ɔ̃], and the sociological variables, and to discover if these variants are subject to social and stylistic variation, a quantitative analysis will be given. Tables showing proportions of responses to sound [a] as opposed to sound [ɔ̃] by style, education, profession, etc. will reveal any possible correlation.

Where statistical tests are concerned, namely in the computation of Chi Square and Exact value test for the variable education, the informants have been divided into four groups: ed.1 is composed of those aged between 15-24 and having had 10 or more years of education; ed.2 concerns those aged 25 and over with the same educational background as ed.1 ; ed.3 is a group composed of informants aged between 15-24 but with 9 or fewer years of schooling; and finally ed.4 comprises those informants of 25 years and over, with 9 or fewer years attendance at school. This age distinction has been made in order to account for those informants who had not yet completed their schooling, although it concerns only ed.1 group. This distinction also makes possible the study of the interdependence of the factors age and education.

Another type of grouping will be used when diagrams will be given for the educational factor. In these diagrams, three groups will appear, namely those with 13 or more years of education, those having had between 10 and 12 years of schooling and finally all informants with 9 or fewer years of attendance at school. This will allow comparison with the other type of grouping, therefore illustrating whether or not the age variable is dependent on education.

The information given in tables will also be shown in graph form, but in this case in terms of percentage rather than in terms of proportions of response. In these figures, the vertical axis will indicate the phonological variables, while the horizontal axis will show the stylistic levels which are used for these variables. The values for each group will be plotted on the diagram and connected along horizontal lines. The diagrams have the advantage of

illustrating both a possible stylistic variation and group stratification. The uniform direction of the lines, with changing values as the progression from style to style occurs, indicates a stratification of these styles according to their formal v. informal characteristics. The separation between these lines indicates the group stratification.

2.2.1 Phonological and syntactic conditioning

The phonological conditioning for the occurrence of a back /ɑ/ as opposed to front /a/ has been described in section 2.2 . It is now clear that back /ɑ/ will be used instead of front /a/ in a final free syllable in words ending in -at, -as, -a for example. However, some further notes must be given on words which have a similar phonological form but which exhibit different syntactic functions. These words concern mainly adverbs, articles, pronouns, etc.

In the case of article la and adverb là, the different syntactic functions lead to different possible surface realizations of /a/, so that:

- 1- la gare would give only one possible surface realization for the article, namely a front unrounded /a/ : [la ga:r]
- 2- là, gare! would be a favoured environment for backing and rounding of /a/ in là, giving therefore the following possible realizations : [la..lɑ...la....lɔ ga:r].

In this case, only the adverb of place will be subject to variations in its phonetic realizations, and not the article.

There also exists in Québec French a particle là which is not semantically interchangeable with the adverb of place. This particle has an emphatic or expletive function. Some examples from recorded speech will illustrate this point.

[jɔ̃ ʒame pɛʁsɔ̃n/ lɔ̃/ ki mɛ lɔ̃ dʒɛ]

"Il n'y a jamais personne, là, qui me l'a dit".

[ʃ vnyɛ nɛʁvø:z / lɔ̃]

"J'suis (de)venue nerveuse, là".

In this case, the pronunciation of là will have the same possible surface realizations as the adverb, i.e. [la... lʌ...lɑ→ lɔ̃... lɔ̃]

Another case concerns the particle ça. When it acts as a subject in a sentence, it has only one surface realization, namely [sa]. However, when it has the role of a complement, either direct or indirect, the phoneme /a/ can undergo a backing and rounding and be realized as [sɔ̃]. Examples will illustrate this point.

[sa vø dʒi:r] "ça veut dire".

[sa s fɛ] "ça se fait".

[i fɛ sɔ̃] "Il fait ça".

[sɔ̃ /ʒɑ̃ vø pɔ̃] " Ca, j'en veux pas".

It can also be said that, when /a/ in ça is found in a nonprominent word final position, the vocalic element will

be realized as a front low unrounded [a], whereas when in a prominent word final position, rounding and backing of the phoneme may occur.

However, [a] in the negative quantifier pas can be realized as [ɔ] whatever its place in the utterance, i.e. in both prominent and nonprominent positions.

e.g. [pur kiʃ blɛs pa (pɔ)]
 " Pour qu'il (ne) se blesse pas"
 [pur pa (pɔ) kiʃ blɛs]
 " Pour (ne) pas qu'il se blesse".

Another case where variations of the phoneme /a/ will occur in formal conversation, is that of verbs ending in -a (-as): in all past tense verbal phrases, like il mangea, il a mangé, and future ones, e.g. il va manger, il mangera, the vocalic segment /a/ will be liable to different surface realizations, i.e. it may be backed and rounded.

In formal conversation therefore, not only words where a posterior /a/ is used because of phonetic conditioning are considered, but all occurrences where particles like pas, ça, là are used as well as verbs ending in this vocalic segment.

Now that description of the environments in which posterior /a/ occurs, and with it a possible backing and rounding into [ɔ], have been determined, a general table will be given to illustrate the average percentage of the use of [a] as opposed to [ɔ] in all environments and speech styles for the 60 informants.

2.2.2 Phonological and stylistic conditioning.

Table 9 illustrates the average use of [a] in three specific environments and by style, in order to give an overall view of the use speakers make of that phoneme, before looking at it in further detail.

Environments	Style			No. of informants
	RS	CS	FC	
[#-a-]	59.8%	53%	4%	60
[-a#]	----	44%	4%	60
[-a[+long]/C ₁ #]	59%	58%	45%	60

Table 9: Average percentage of [a] for the 60 informants by environment and style.

To compare the phonetic environments together, formal conversation will first be considered. This style is the one where the speech of individuals comes closer to their everyday speech. Among the different styles elicited here, it is certainly the one where the least attention is focused on pronunciation. It is when people speak "naturally" that the true value given to a variable appears. By true value is meant not a subjective one, or one which carries prestige for the speakers, but rather the value of the variable which is associated with the pre-adolescent speech pattern, i.e. the period where language is thought to be fixed (cf. W.Labov, (1966a)). Variables may gain different values when

one grows up, but it is at the conscious level first (as illustrated by the more formal styles) that this can be observed. It takes a long time before these new values are used spontaneously without effort.

In this style, nearing everyday speech, the phonetic conditioning of use of [a] appears clearly. For [a] in a non-final and final free position, only 4% occurrences of an open back unrounded variant are found. The average use of [a] for the whole of the sample is very small and almost nonexistent. The half-open back rounded variant [ɔ] holds a strong position in these two environments.

However, when the phoneme is in a final closed syllable, the use of [a] is at a 45% level. Whereas [ɔ] is used almost 100% of the time in the two preceding environments, it falls to an almost 50-50 co-variation with [a] in a final closed syllable.

How can such a discrepancy be explained? [a] in a final closed syllable is, in the words considered here, always long. A long vowel, as will be seen in the case of other vocalic segments, may be realized as a segmentation of the phoneme into a more open segment and a closer one in the same vocalic area. This possible diphthongization of the vocalic element may account for the fact that, when [a] is in a final closed syllable, fewer responses to [ɔ] are given than in the other two environments, where only the variant [ɔ] can co-vary with [a]. The discrepancy between environments may be explained in terms of a choice offered to the speaker. When dealing with variable (a)-1 in a non-final and final free position, he has the choice of two possible sets of pronunciation. Either he uses the set on the open axis,

i.e. [a..A..a] , or he uses the one involving rounding and backing features, i.e. [ɔ..ɔ̄..ɔ̄] . But when dealing with variable (a)-1 in a final closed syllable, three sets of pronunciations are offered to him. The two preceding ones plus one involving diphthongization of the phoneme into [A^u: -a^u :- ɔ̄^u:] ,etc.

This is not to say that these choices are made consciously in everyday speech, but only that they are possible complementary surface realizations of the phoneme.

When considering the more careful styles, the picture is somewhat different. In these styles the attention of the speakers is focused on pronunciation of the words. The subjective value attributed to a particular variant is expected to appear in these styles. As shown by the percentage of occurrences of variant [a] , an important style shifting is found for [a] in a non-final and final free syllable. Whereas all the informants used only 4% of the open back unrounded vowel in formal conversation, the use of this vocalic element rises to 50% and over in the more formal styles. This large discrepancy between formal and informal speech indicates that, generally, people consider the open back unrounded variant as being a feature of more formal styles. The style shifting for [a] in a final closed syllable is much less important. The use of [a] increased by 13.5% as opposed to 40% and over 50% in the other environments.

From the general picture given by table 9, it can be observed that, in the two careful styles, no phonetic conditioning seems to affect the use of [a] as opposed to [ɔ̄] . In all three environments, the open back unrounded vowel displays variability and the rule for selection of [a] or [ɔ̄] is optional, although [a] is favoured at a lower degree

in a final free position. In formal conversation, the informants favoured a half-open back rounded variety in a non-final and final free position far more than in a final closed syllable. The discrepancy between these environments has been explained in terms of the choices offered to the speaker. However, since no phonetic conditioning applies in more formal styles, since in these styles [ɑ] and [ɔ] co-vary at about the same level in all three environments, and since the use of [ɑ] increases considerably in more formal styles, the discrepancy between the environments found in formal conversation might also be explained in terms of awareness of [ɑ]. In final free and non-final positions, [ɔ] is widely selected compared to its use in a final closed position. The awareness of [ɑ] seen in the more formal styles does not seem to have had an effect on a less formal style of speech in these two environments. On the other hand, use of [ɑ] seems to have gained favour in formal conversation, when it occurs in a final closed syllable. It might be that [ɑ] and [ɔ] co-vary in formal styles in all three environments, whereas this co-variation affects only the vocalic segment in a final closed syllable where a less formal speech style is concerned. This phonetic conditioning seen in formal conversation might indicate a linguistic change, in which [ɑ] would be in a process of being more widely selected in everyday speech. A more detailed discussion on this matter will be given in the following sections.

This general table demonstrates that variable (a)-1 is subject to stylistic conditioning and to phonetic conditioning, when formal conversation is considered. However, in order to see if the variable is also subject to social differentiation, different social groups will be considered.

2.2.3 Differentiation by education

Table 10 shows the proportional responses to sound [a] as opposed to sound [ɔ] by educational groups.

Educational groups	non-final position			final free position		final closed position		
	RS	CS	FC	CS	FC	RS	CS	FC
ed.1	.769	.653	.061	.656	.000	.923	.831	.584
ed.2	.715	.718	.062	.681	.086	.694	.745	.606
ed.3	.700	.400	.000	.107	.000	.363	.214	.000
ed.4	.153	.180	.000	.023	.000	.064	.049	.095

Table 10: Proportional responses to [a] by environment, education and style.

The variations found in the general table 9 still hold good in this more detailed table. Taking first formal conversation into account in a comparison of the behaviour of the four groups, the following observations may be made: Statistically speaking, a significant discrepancy is found only when a comparison is made between ed.1,2 and ed.3,4 in their use of [a] in a final closed syllable. The gap between these two educational groups is very wide in that the informants having 10 or more years of education used the open back unrounded variant around 50% of the time, whereas those with 9 or fewer years of education almost never used this variety. Although no big discrepancy exists between the groups when [a] is considered in non-final and final free syllables,

there are nevertheless interesting factors to be noted.

In a non-final syllable, the same opposition as that found in a final closed syllable is maintained, in that ed.1,2 used the open back unrounded [ɑ] at least occasionally, as opposed to ed.3,4 who never used this variant in formal conversation. When variable (a)-1 is in a final free syllable, three groups show a categorical non-use of [ɑ], i.e. ed.1, 3 and 4. Only those aged 25 and over and having 10 or more years of education used the unrounded variant, although at a very low level.

If an ordering of the behaviour of the groups is made, accounting for the importance of [ɑ] in each phonetic environment for each group, the following occurs:

[ɑ] in a final closed and non-final syllable → ed.1,2
 [ɑ] in a final free syllable —————→ ed.2

It is only in these environments that an appreciable use of [ɑ] is found. The main environment favouring the use of an unrounded variety is here when the phoneme is found in a final closed syllable, but this holds true only where ed.1 and ed.2 are concerned.

A categorical use of the rounded variant applies for: ed.3,4 in a non-final syllable, ed.1,3,4 in a final free syllable, and ed.3 in a final closed syllable. The position where [ɔ] is more favoured is in a final free syllable, although its use is almost as extensive in a non-final syllable. Only ed.1 and 2 used the unrounded variety to a large extent in a final closed syllable. It is only in this environment that [ɑ] gains in importance, whereas elsewhere the rounded variant has the advantage over the unrounded one.

The informants with 9 or fewer years of education behave quite consistently towards this variable in formal conversation. In fact, they never (except for a 9% use for ed.4 in a final closed syllable) use the unrounded back [ɑ], whatever its place in the syllable. The older and more usual, or more natural, back rounded variety maintains the strong position.

On the other hand, informants with 10 or more years of education do not behave so consistently. When the three environments are compared, different reactions towards [ɑ] occur. Where these groups almost never use [ɑ] in a non-final and final free syllable, like their less educated counterparts, they move to near 60% use of the unrounded variant in a final closed syllable. This indicates a very large difference. Whereas [ɔ] is dominant in the two first phonetic environments, it loses its position in favour of [ɑ] in the remaining one. In order to assess whether this discrepancy indicates a possible linguistic change, the more careful styles must be investigated. In these styles, the subjective value accorded to a variable will in fact appear, or what people consider to be the form associated with formal styles of speech.

In careful style, the picture derived from the study of formal conversation differs considerably from that obtained from an investigation of careful style. In the latter style, it can clearly be seen that the open back unrounded [ɑ] is considered as the form to use when attention is focused on pronunciation. It is interesting to note that the tendency towards [ɑ] by ed.1 and 2 in all three phonetic environments comes near to that which obtained for formal conversation in respect of a final closed syllable.

When the four educational groups are compared for careful style, strong evidence exists against the hypothesis that all groups will behave in the same way towards sound [ā]. Ed.1 and 2 are not differentiated. These two together show a discrepancy when compared to ed.3 and thereafter with ed.4. In all three phonetic environments, the same significant difference between the groups occur:

- 1- ed.1 and 2 use the unrounded variety over 65% of the time.
- 2- ed.3 between 10% and 40% of the time.
- 3- ed.4 uses this form below 18% of the time.

This indicates clearly an educational differentiation. The age factor also plays a certain part in that those aged between 15-24 with 9 or fewer years of schooling move away from their older counterparts. They seem more aware of another variety which is related to a more "correct" or prestige pronunciation.

This tendency of the informants belonging to ed.3 group is illustrated when their behaviour in reading style for [ā] in a non-final syllable is considered. In this style, their use of an unrounded variety is equivalent to that of their more educated counterparts. This is relatively significant. In the more careful styles, this group always behave rather differently from their older counterparts. Most of the time, they fall in between ed.1,2 and ed.4. Only in reading style, for [ā] in a non-final syllable, have they succeeded in approximating significantly to the more educated groups.

The behaviour of the four educational groups towards variable (a)-1 in more formal styles of speech gives an indication of the different value attributed to the open back unrounded variety. All groups display in fact sharp stylistic variation when moving from a less formal speech to more formal

ones. For every group, the greatest stylistic variation is found where (a)-l occurs in a non-final and final free syllable. In these positions, the greatest variation concerns those having 10 or over years of education, although ed.3 shows great stylistic variation in a non-final syllable. It is also interesting to note that the informants with 9 or fewer years of education and aged 25 and over (ed.4) show almost no stylistic variation in either environment where variable (a)-l is found.

Another interesting fact is the behaviour of those aged between 15-24 towards variable (a)-l in a final closed syllable. Although ed.1 and 3 are clearly differentiated from one another in all contextual styles, they nevertheless present the same pattern of behaviour. They both use more of the unrounded variant in reading and careful styles compared with their older counterparts. However, in formal conversation, they use this variety rather less often than the older informants, although the differences are not very important. It is probably too early to talk about a linguistic change in progress as far as variable (a)-l is concerned. In fact, all groups behave in almost the same way in formal conversation, except when the variable is found in a final closed syllable. However, there are at least some indications that [a] is in the process of becoming more widely used, as indicated by its % of occurrence in a final closed syllable and in the two other environments where more careful styles are concerned.

The use of an open unrounded vowel as opposed to a rounded one is strongly focused on in circumstances where a more formal speech situation is concerned. This phenomenon is accentuated by the fact that at school, on television, radio, etc., i.e. in all situations where a more careful speech

style can be predicted, the variant [a] is preferred. The researcher's native knowledge of the language investigated in this study, together with personal experience at school and observations of radio and television speakers, make this assertion possible. The claim is moreover confirmed as one looks at the more careful styles elicited in the course of the interview. The use of the open back unrounded variety is strongly favoured by the more educated groups and even in some environments by the younger, less educated. [a] is certainly associated with careful speech. However, will this variety gain favour in everyday speech? Will a linguistic change take place? Since the rounded variety [ɔ] is used at almost a 100% level in two environments by all informants, it seems unclear whether such a change is taking place at present. Nevertheless, ed.1 and 2 show variation in using both [a] and [ɔ] in a final closed syllable. In this environment, variations are already present, whereas they have not affected to any marked extent the two other environments. The study of the age factor will give more details on this particular point.

At present, the following tendencies can be postulated:

- 1- ed.1 and 2 are differentiated from ed.3 and 4 when the two careful styles and all three phonetic environments are considered. They are also differentiated in formal conversation in the case of variable (a)-1 in a final closed syllable.
- 2- The amount of style shifting is very large, especially for ed.1 and ed.2. Their pattern of behaviour towards the variety [a] in the two careful styles is almost the opposite of that found in formal conversation. This might indicate linguistic insecurity (cf. P. Trudgill, (1974); W. Labov, (1966a)). While these groups are not to any large extent

differentiated from those who have had 9 or fewer years of education in formal conversation, they move far apart in more careful styles. In these styles, they are aware of a "norm", which they do not realize in a less formal style, although they obtain a certain success when (a)-l is in a final closed syllable.

3- The young, less educated informants also display considerable style shifting, sometimes nearing the more educated, sometimes approximating rather to their older counterparts, sometimes falling between both.

The type of educational grouping observed above accounts for important differentiations between informants and styles of speech.

However, this grouping concerns only two educational categories. Thus, in order to see if variable (a)-l is involved in more complex educational relationships, the grouping dividing informants in three groups, as described at the end of section 2.2., will be investigated.

Figures 1, 2 and 3 show the patterns of behaviour of these groups in respect of their use of the open back unrounded variety. It is immediately apparent that the statistically significant discrepancies concern informants with 13 or more years of education and those with between 10 and 12 years of schooling against respondents with 9 or fewer years of attendance at school. These significant discrepancies operate most clearly in the more formal styles, as was the case for the educational grouping taking into account the age parameter.

Nevertheless, the patterns of behaviour shown in figures 1, 2 and 3 demonstrate the tendencies illustrated

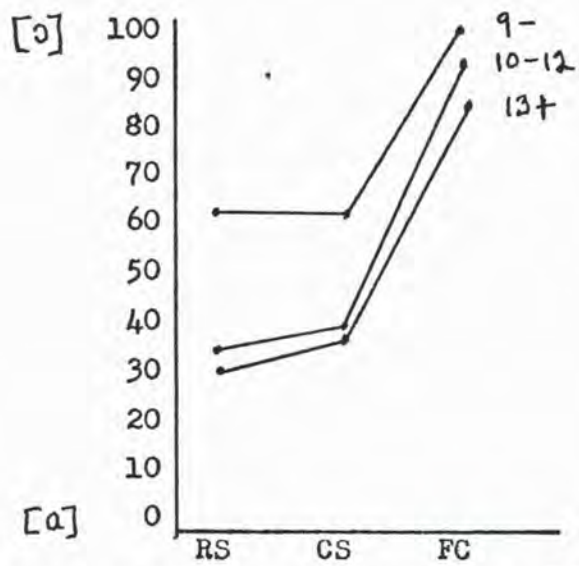

Fig.1 % of responses to [a] in a non-final syllable by education and style.

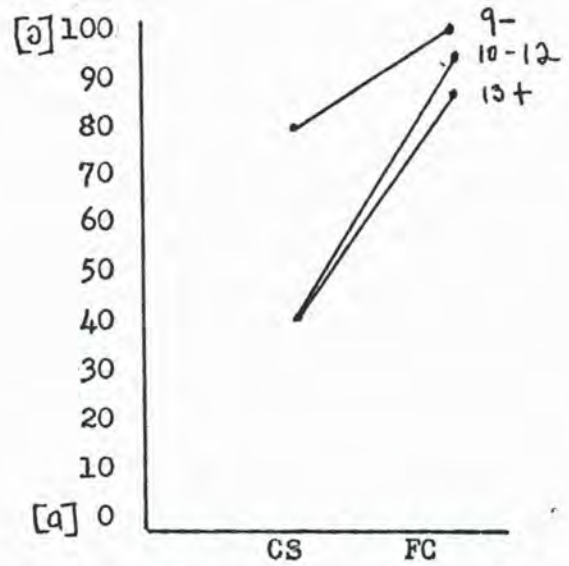

Fig.2 % of responses to [a] in a final free syllable by education and style.

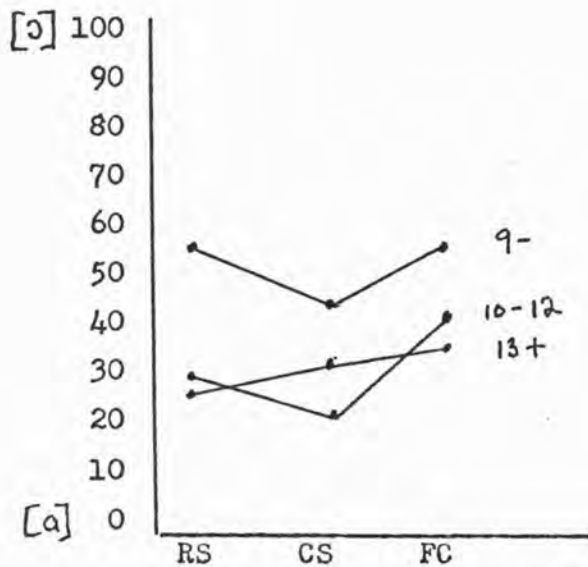

Fig.3 % of responses to [a] in a final closed syllable by education and style.

in the previous comparison of educational groups. In formal conversation, it is in fact when variable (a)-1 occurs in a final closed syllable that the most important differences are to be observed. It is also in this phonetic environment that the lowest degree of style shifting is found. However, whatever the phonetic environment considered, the significant ordering to account for a more frequent use of [a] in formal conversation is as follows : 13+ > 10-12 > 9-. In this ordering, a greater frequency of occurrence of [a] can be observed in the most educated group, with thereafter a regular decrease being encountered in informants having had between 10 and 12 years of schooling and finally in the least educated informants. The discrepancies between these three groups are very low, but they nevertheless indicate interesting tendencies, i.e. that in everyday life, the open back unrounded variety [a] functions as a prestige marker of the highest-ranking educational group.

However, as one follows the progression towards more formal styles, the second-ranking status group shows a rapid increase in the values of [a], until it has almost the same usage as that of the highest educational group and even surpasses the usage of this latter group. The crossover pattern observed for variable (a)-1 in a final closed syllable appears to be a deviation from the regularity of figures 1 and 2. To describe this phenomenon, the term hypercorrection (1) will be used, since the second highest educational group goes beyond the highest educational one in its tendency to use the form considered appropriate for formal styles. This group shows a pattern of hypercorrection in the phonological environment where variability in the application of the rule

(1) The term "hypercorrection" has been used by W.Labov; see particularly W.Labov, (1964b).

/ɑ/ → ⟨[ɔ]⟩ (1) is already present in everyday speech, i.e. in a final closed syllable. In addition, it is in this environment that indication of a linguistic change appeared as the informants aged between 15-24 used the unrounded variety more frequently than their older counterparts in more formal speech styles. This indication of a linguistic change affecting the social value attributed to [ɑ] was mostly represented in young, more educated informants.

The special hypercorrect pattern of behaviour of the second-highest educational group in a final closed syllable indicates the special role this group may have in a linguistic change, as represented by its sensitivity to social pressures from above (2).

Observation of the educational parameter has provided evidence for the assumption that the variety [ɑ] constitutes a feature associated with formal styles of speech. This variety is moreover a feature of higher educational groups, and indication of a linguistic change appeared most clearly in the usage young, more educated informants made of [ɑ] when the variable is considered in a final closed syllable. The indication of a linguistic change, especially in the latter phonological environment, seems to be confirmed by the pattern of hypercorrection observed in the second-highest educational group. However, before drawing more definite conclusions on this matter, the remaining sociological parameters will be considered.

-
- (1) For the use of the angle-bracket notation, see W.Labov, (1969a).
 (2) For similar patterns of hypercorrection by the second-ranking status group, see W.Labov, (1964b) and (1966a).

2.2.4 Differentiation by occupation

Figures 4, 5 and 6 give the relationship between professionals, white collar workers and manual workers, when their behaviour towards the open back unrounded variety is considered in its three phonetic environments.

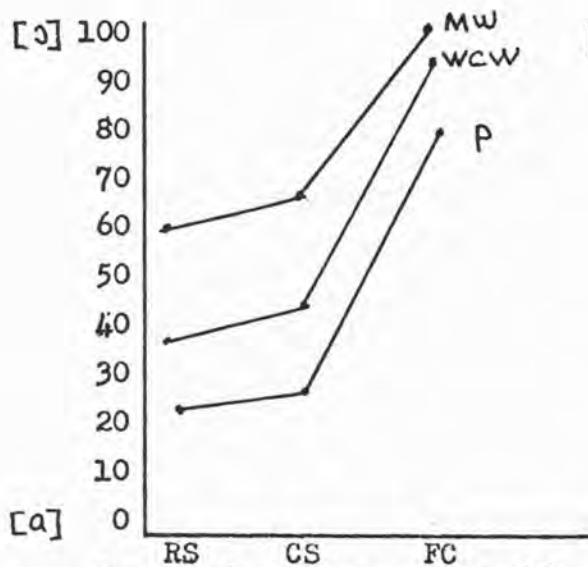

Fig.4 % of responses to [a] in a non-final syllable by occupation and style

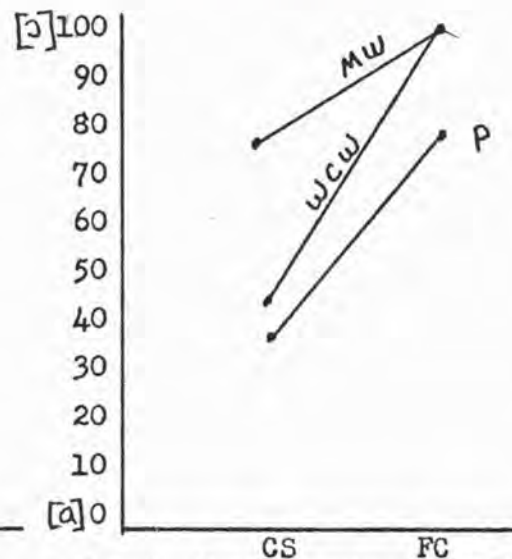

Fig.5 % of responses to [a] in a final free syllable by occupation and style

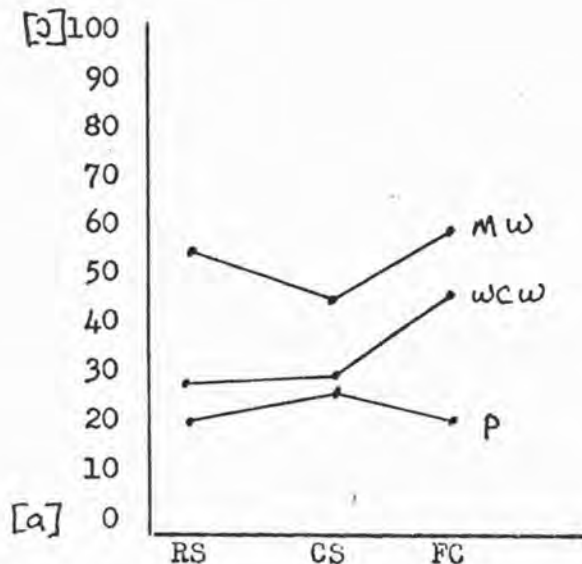

Fig.6 % of responses to [a] in a final closed syllable by occupation and style

As was the case for the education factor, the groups are not differentiated to such a marked degree when formal conversation is considered. However, a somewhat sharper stratification appears in that professionals behave differently from the other groups. White collar workers in fact tend to approach manual workers in this style for the three environments. In the case of (a)-l in a non-final and final free syllable, the use of a half-open back rounded variant is almost categorical for manual and white collar workers. Professionals stay apart in that they use this variant 82% of the time. As for variable (a)-l in a final closed syllable, the number of occurrences of the rounded variant is much less important than in the two previous environments. For manual and white collar workers, these rise to around a 50% level whereas they remain at the low level of 20% for professionals. Thus, in formal conversation, the significant discrepancy concerns professionals as opposed to white collar workers and manual workers.

In the case of the more careful styles, a large amount of stylistic variation appears for variable (a)-l in non-final and final free syllables. In these styles, white collar workers and professionals have the greatest stylistic variation, as shown by the lines which have the steepest gradient. Although the three groups are distinct in these careful styles, the important discrepancy now concerns professionals and white collar workers as opposed to manual workers. These last also show a small amount of stylistic variation, thus demonstrating that they too consider a wider use of an open unrounded variety as being more appropriate to formal forms of speech. But the subjective value accorded to [q] is better shown in the case of the two other occupational groups, who from an over 80% use of the half-open rounded

sound drop to about a 40% use in the more careful styles. These two groups certainly show more awareness of a "prestige" form. However, the degree of stylistic variation is generally less important when variable (a)-1 is in a final closed syllable.

From the pattern of behaviour of white collar workers, i.e. the second-ranking status group, conclusions similar to those made in the study of educational groups may be drawn. In fact, this group is the only one showing an important style shifting when the variable is in a final closed syllable. In addition, although there exists no pattern of hypercorrection, the fact that white collar workers hover between two extreme groups, by coming close to manual workers in formal conversation in their use of [ɔ] and on the other hand by approaching the pattern of behaviour of professionals in more formal styles, demonstrates the sensitivity of this group to a prestige form represented in the highest-ranking status group.

This phenomenon might indicate linguistic insecurity, which is at the highest level in the second-highest occupational group. The idea of linguistic insecurity, which can be viewed in the degree of stylistic variation present for a variable, is not a new one. Labov, Trudgill and many writers have discussed this matter in previous works. Variable (a)-1 constitutes a prestige marker, in which the open back unrounded [ɑ] is a feature of more formal speech styles mostly represented in the highest-ranking educational and occupational groups. This fact is confirmed by the social and stylistic stratifications found in these two sociological parameters.

All groups of speakers examined show their awareness of [ɑ] by displaying style shifting. However, this style

shifting, indicating linguistic insecurity, is the greatest in the second-ranking status group, decreasing thereafter in the highest one, and finally in the lowest-ranking status group.

In general, it can safely be assumed that two patterns of behaviour exist as regards variable (a)-1 : one which is associated with an everyday speech, favouring in this case the use of a half-open rounded variety [ɔ] , and one which is related to a more formal speech, i.e. favouring rather an open unrounded variety [a] . To what extent different groups of speakers use these two variants is a question of degree, rather than one of all-or-none. Variability is present in most cases, so that for almost all groups, the rule governing the use of [a] or [ɔ] is optional rather than categorical. For manual workers, however, as for those who have had 9 or fewer years of schooling, this optional rule becomes categorical when variable (a)-1 occurs in a non-final and final free syllable in formal conversation .

Occupation appears as an important parameter in accounting for variations within the sample. The distinction between the occupational categories is especially striking when the formal styles are considered, and even in formal conversation where (a)-1 is in a final closed syllable.

2.2.5 Differentiation by sex

Table 11 gives the proportional responses to the open unrounded variant by sex for the three phonetic environments.

As was seen for the two preceding sociological parameters, it is when careful styles are considered, that the differences between various groups become significant.

	Non-final syllable			Final free syllable		Final closed syllable		
	RS	CS	FC	CS	FC	RS	CS	FC
Male	.458	.450	.046	.382	.050	.447	.468	.367
Female	.747	.672	.040	.589	.033	.777	.801	.597

Table 11: Proportional responses to [a] by environment, sex and style

Except for (a)-1 in a non-final and final free position in formal conversation, the difference in the proportional responses to sound [a] between these two groups range from .200 to .330 . It was said in section 1.3.3 on statistical methodology that a difference in the proportions of the order .2 to .3 would be insufficient to indicate a clear-cut discrepancy between various groups. Therefore, in the case of sex groups, it cannot be said for certain that there is real evidence that these two groups have a statistically significant different behaviour in their use of the unrounded [a] . Nevertheless, the difference is sufficiently marked to be of interest. The relationship in the patterns of behaviour of the two groups is in fact consistent. For formal conversation where (a)-1 is in a non-final and final free position, no discrepancy occurs whatsoever. Both groups use the half-open back rounded variant [ɔ] over 95% of the

time. However, in all other cases (i.e. all styles, all phonetic environments) , the groups keep a constant proportional difference of .200 to .300. This shows a relatively regular pattern of behaviour. In all these cases, women seem to favour the open unrounded variety to the half-open rounded one to a greater extent than men. Trudgill (1974,p.94) suggested certain explanations to account for such a sex differentiation. He states for example, that because women cannot, most of the time, be rated socially by their occupation, they use other means like speech to identify themselves with a particular group.

Another factor which might explain a certain sex differentiation found in speech is that women and men in our society do not receive the same education. Women, for example, are expected not to swear, to dress more neatly, to behave with more "refinement", etc. All these social requirements imposed on women may explain why women are more aware of certain social attitudes and of certain forms of speech than men are.

As far as stylistic variation is concerned, both groups show a high degree of style shifting, although this shifting is more prominent for women. As for education and occupation, the significant stylistic variations do not concern reading style compared with careful style, but rather these two as compared with formal conversation. The emphasis is therefore put on the opposition of formal v. less formal situations. Especially for women, stress is put on the realization of an open unrounded variety in formal styles. In formal conversation, the half-open back rounded variant holds a very strong position when variable (a)-1 occurs in final free and non-final positions. It is thus in these environments that the sharpest stylistic stratification will be found.

In the case of variable (a)-1 in a final closed syllable, the same pattern occurs as those found for education and occupation. A certain balance between [a] and [ɔ] seems to have been obtained here. Women use the open unrounded variety [a] between 59% and 80% of the time. Men use it between 36% and 46%. The differences between men and women in this environment remain constant in the three different styles. In addition, the degree of stylistic variation is very low for both groups, compared with that found in the two other environments. It seems as though, in formal conversation, the use of the two varieties [a] and [ɔ] is so balanced that no need is felt to correct a too high percentage of [ɔ] in more careful styles. Co-occurrence of both forms seems to be appropriate since no high disproportion between both sounds is found in either styles of speech.

In a final free and non-final position, however, usage of [ɔ] is so high in formal conversation that it drops sharply in more careful styles. It is interesting to note that although [a] is used extensively in these careful styles, it still alternates significantly with [ɔ], so that both forms have an important percentage of occurrence.

2.2.6 Differentiation by age

Labov wrote that "[v]ariability itself is change: but some types of variation are themselves invariant from generation to generation" (1). It has already been observed that variable (a)-1 is involved in social and stylistic variations. Such variations lead immediately to the question

(1) W.Labov, (1966a), p.318

of linguistic change. The hypercorrect pattern of the second-ranking status group observed in section 2.2.3, together with the higher values [ɑ] is gaining in formal speech styles when younger speakers are considered, and finally the behaviour of women who demonstrate more sensitivity towards prestige patterns than men, have already given an indication of a linguistic change affecting the social value attributed to the open back unrounded variety, especially when this variable is found in a final closed syllable.

In order to see if this variable is variant from one generation to the other, it will be considered through the age variable. It remains to be seen whether the change observed in other groups is reflected in the values which each generation attributes to this variable, i.e. to observe it in what Labov has called "apparent time".

Table 12 portrays the behaviour of the three age levels towards variable (a)-1.

Age	Non-final syllable			Final free syllable		Final closed syllable		
	RS	CS	FC	CS	FC	RS	CS	FC
15-24	.750	.583	.044	.504	.000	.800	.710	.447
25-44	.597	.490	.022	.504	.000	.560	.613	.469
45+	.494	.597	.058	.458	.104	.500	.584	.488

Table 12: Proportional responses to [ɑ] by environment, age and style.

The only statistically significant differences found concern the younger informants and the older informants when variable (a)-1 is in a non-final and final closed syllable in reading style. This difference is of the order of .256 in a non-final syllable and of .300 in a final closed syllable. Such an order of discrepancy is lower than that found for education and occupation, for example. Reading style is the most careful of the styles elicited in this research. In this situation, young informants aged between 15-24 seem more aware of the form associated with "good" speech. While the latter use the open unrounded variant around the 75% level, those aged between 25-44 stay around the 55% level, and finally the older informants vary around a 50% mark. There is certainly a sign here that the younger the informants are, the more they will favour the open back unrounded variant in very careful speech.

However, if formal conversation is considered, there are no longer significant discrepancies to be found in either environment. The use of the half-open back rounded variety is the form favoured by all groups, mainly in a non-final and final free position. In the latter however, it is interesting to note that those aged 45 and over use the unrounded [ɑ] in a proportion of .104, whereas the two other groups have a categorical use of [ɔ]. But the differences between the age groups is so slight in formal conversation that no change in the value of the variable seems to be present at the moment.

Stylistic variation here again is mainly important in the case where variable (a)-1 occurs in a non-final and final free syllable. There is a slight stylistic variation to be found in a final closed syllable, but it is less striking than in the two other environments. Only those aged

between 15-24 show a different behaviour in that environment. They seem here to form the most insecure group, in which the sharpest stylistic variation occurs in most environments.

A conclusion which can be drawn from all preceding observations is that, if formal conversation is considered, i.e. the style approximating to everyday speech, a categorical use of the half-open back rounded variety [ɔ̞] can be predicted for almost all speakers when the variable is in final free and non-final positions. Examples of speech, as the following, seem normal for everyone:

- Inf.2 [se sy^ʰksa[•] de ptstrt bɔ[•]ʌjɛ:^ʰ]
 "C'est sûr que ça a des petites barrières".
- Inf.18 [sa mɛ[̣] deʒɔ[̣] vny a lide siʒgɔ̞pɛ[̣] kək {o[•]z̞}] (1)
 "ça m'est déjà venu à l'idée, si je gagnais quelque chose".
- Inf.24 [la frãsãe dz̞[̣] kɛbɛk / paʎle pɔ[•]tɔ̞]
 "Le français du Québec, parler "pâteux" ".
- Inf.38 [kɛkə {o:z̞ kɔ̞m sɔ̞ / lɔ̞}]
 "Quelque chose comme ça, là".
- Inf.1 [se bɛ̞[̣] biza:ɕ]
 "C'est bien bizarre".

(1) The following diacritical marks will be used in the phonetic notation:

- ˆ : = consonants and vowels partially devoiced
- : after a symbol = without audible release
- ◌̣ : below a symbol = completely devoiced
- ˜ = weaker articulation
- ʌ = vowel between /a/ and /ɑ/
- ɳ : beside a letter = nasal release

- Inf.32 [siʒ la gɔːpɛ / pøtəːt de ptʰit, gɔːtri]
 "Si je la gagnais? Peut-être des petites gâteries".
- Inf.34 [si ʒ rʰkʰɔːt ʏn pɛrsɔːn/ pɥɪ kɛl v tu pɥ la
 pɛrsɔːnalte / pi kɛl v v la bɥ / sa z gä:t /
 as mɔmÄ lɔ /]
 " Si on rencontre une personne, puis qu'elle a tout
 pour la personnalité, puis qu'elle ouvre la bouche:
 ça se gâte. A ce moment là, ..."
- Inf.53 [ʒÄ dönrÉ a ma mɛː / la tɾwɔ kɔːr]
 "J'en donnerais à ma mère, les trois-quarts".
- Inf.37 [pɔ syːf la fɛ lɔ / ʒe vy dɔ tʰip ä bʰisʰk gɔzəlɾn
 lɔ / etæ tʰbeä bɔ d lœ:r bisʰk]
 " Pas sur le fait, là. J'ai vu deux types en bicyclette
 (à) gazoline, là. (Ils) étaient tombés en bas de
 leur bicyclette".

2.2.7 Conclusions

The following conclusions can be drawn from the study of variable (a)-1.

1- In formal conversation, variable (a)-1 is not so involved in a process of variability. Indeed, no significant differences were found between either group, as far as their behaviour towards the variable in a non-final and final free position is concerned. In these two environments, only seven informants: (2 male professionals, 4 female professionals, 1 female white collar worker) showed an optional application

of the rule $[a] \rightarrow \langle [v, \text{ɔ}] \rangle$. The remaining 53 informants applied the rule categorically. This is significant, in that it shows that the majority of speakers favoured at a 100% level the 'half-open back rounded variety.

However, in a final closed syllable, the categorical value attributed to the half-open back rounded variant alters considerably. In fact, in this environment, only 16 out of the 60 informants used this variety categorically.

If individual speakers are considered, the picture for formal conversation is as follows: 2 informants show an optional selection of the rule $[a] \rightarrow \langle [v, \text{ɔ}] \rangle$ in more than one environment at a time; 16 informants show a categorical application of this rule in all three environments; 21 informants have a 100% use of $[\text{ɔ}]$ in a non-final and final free position, but 0% in a final closed syllable; and finally, 21 speakers use $[\text{ɔ}]$ categorically in a final free and non-final position but optionally in a final closed syllable.

This behaviour of speakers seems to support the view, as elaborated by Bickerton (1971), that for any particular speaker, variability in a particular rule can only exist in one environment at a time, and that after a rule has become categorical in one environment it can begin to be applied optionally in another environment.

This seems true in the case of variable (a)-1 . This view is however too extreme in that it does not account for the fact that selection or non-selection of a rule is determined not only by the phonetic environments in which it occurs, but also by the characteristics of a speaker and groups of speakers, and moreover by the type of situation the speakers face.

In fact, selection or non-selection of the rule $[a] \rightarrow \langle [v, \text{ɔ}] \rangle$ is determined by stylistic and sociological factors, and the application of the rule by various groups implies differences of degree rather than categorical differences. In the case of variable (a)-1 in a final closed syllable, significant differences were found between educational, occupational and sex groups. What the results demonstrate is that higher rates of use of $[\text{ɔ}]$ are a tendency of those having 9 or fewer years of education, and falling within the category of manual workers. In addition, men are more likely to favour this variant than women. The differences found between the groups is certainly a question of proportions in the degree of occurrences of the rule rather than of its total presence or absence.

Moreover, as a more careful speech situation comes into play, here represented by the two careful styles, the whole pattern given by formal conversation alters. In careful style, for example, only 1 informant showed a categorical selection of $[\text{ɔ}]$ in the three phonetic environments. 8 informants applied the rule categorically when the variable is in non-final and final free positions. However, what is more interesting is that 33 informants used $[a]$ and $[\text{ɔ}]$ optionally in more than one environment at a time. The situation no longer arises where variability in a particular rule can only apply in one environment at a time for a particular speaker. Indeed, more than half of the informants showed variability in more than one environment at a time.

Variability in the use of $[a]$ and $[\text{ɔ}]$ is here again a question of degree when differentiation between groups is concerned, and is also closely related to sociological parameters.

In the case of careful style, it can be said that, when facing a more formal situation, all informants are able to assign a different value to the variable, (i.e. giving [a] a higher % of occurrences) . The difference lies in the proportional response each group gives to this value.

Variable (a)-1 illustrates the fact that application of the rule $[a(:)] \rightarrow \langle [b(:), \text{ɔ}(:)] \rangle$ is a function of phonetic environment, of styles of speech (formal v. less formal), as well as of sociological factors. Speakers seem to have "internalized" different types of behaviour towards this variable. As Trudgill puts it: " They "know", as individuals, the probability of operation of this rule in particular social contexts" (1).

The idea developed by this discussion is that speakers are able to behave both in terms of categorical rules and of those of probability. According to the "true" and subjective value attributed to the variable, according to the type of situation faced, according to the social characteristics of a given speaker or group, and finally according to the phonetic environment concerned, use or non-use of a variant will be applied in a different way, sometimes showing categorical behaviour, sometimes variable behaviour, in which the differences are a question of degree. By "question of degree" is meant that speakers know when to use a variant at a very high degree of occurrence, at a lower level and at a very low level, and that representation of one or another level will be determined by sociological factors, and by the type of situation faced, i.e. very formal, less formal, the least formal.

(1) P. Trudgill, (1973), p.156

2- Where variability was found, differences between various groups also occurred. The most significant difference was provided by the comparison of educational and occupational groups, then by sex and finally by age. So that when the degree of significance is the factor considered, the sociological parameters follow the order: education & occupation > sex > age.

3- The degree of style shifting present in the behaviour of groups towards variable (a)-1 is very high. The greatest stylistic variation occurred when formal conversation was compared with the two other styles elicited. For all groups, there was a slight increase in the use of [ɑ] as they moved from careful style to reading style. But the difference between these styles remained low, so that the significant stylistic variation involved comparison of formal v. less formal situations. Moreover, groups were differentiated generally at about the same level of significance in the two careful styles, so that no real large discrepancy was found between the two styles in differentiating groups. The types of speech which will claim the most attention will be those of a formal type v. a less formal type.

It appears clearly from the results that the amount of style shifting is proportional to the use speakers make of the half-open back rounded variant [ɔ] in formal conversation, as well as to the degree of awareness they show of the variety associated with a more careful form of speech, i.e. [ɑ] .

As seen in the various tables, selection of [ɑ] and [ɔ] was made optionally when the phoneme occurred in a final closed syllable. In this environment also, the lowest amount of style shifting was found when this environment was considered

in more careful styles. However, in the two other environments, [ɔ] was selected categorically by almost all speakers in formal conversation, so that the amount of style shifting found was especially impressive as one moved to more careful styles.

The groups who showed the greatest awareness of [ɑ], also having the highest style shifting, are the more educated, professionals and white collar workers, women and young informants. In addition, the group composed of young informants with 9 or fewer years of schooling have a significant style shifting.

4- Inferences with respect to linguistic change are generally best based on the distribution of the value of the variables within the population sampled at one particular time. In the simplest case, the proportion of occurrence of a particular variant is correlated with age. As seen in the conclusions concerning the variable in formal conversation, no significant age differentiation could be found, but a small one did occur when the variable was considered in more formal styles. The unrounded variant [ɑ] is certainly gaining favour within the sample studied, since young informants, independent of their educational background, showed greater awareness of this variant than their older counterparts. It might, however, be too soon to postulate a linguistic change in progress.

Nevertheless it has to be remembered that the age distribution is very often complicated by the fact that a linguistic change may follow more complex patterns. It may originate in a particular class, occupational or sex group, etc., and spread from there to other groups, so that a change

may be found in one subgroup of the population, whereas it has barely begun in another segment.

The use of [ɔ̃] is a feature characteristic of Québec French in general. But it has always co-existed, albeit uncounsciously, with an open back unrounded [ɑ] in the speech of the community. Usually, [ɑ] has been the variant heard on radio and television, in speeches, etc. From the data obtained in this study, it seems that variant [ɑ] does in fact exist in the repertoire of most speakers. Therefore, both forms are part of the competence of any speaker. The behaviour of speakers or groups towards the two types of articulation is still strongly dependent on the type of situation in which they find themselves. A formal situation will lead to a greater use of [ɑ], whereas a less formal one will lead to its virtual disappearance. [ɑ] and [ɔ̃] already coexist at the performance level in the latter situation, as seen in the case where the variable occurs in a final closed position. In this environment, phenomenon of hypercorrection by the second-highest status group, sex and age differentiations have been found. It is possible that these above factors might indicate a linguistic change in progress.

It cannot be said that [ɑ] will one day replace [ɔ̃] completely, but some other predictions may be made. Since young informants showed a greater use of [ɑ] in a very careful style, since this variety is used quite often by certain groups in careful styles of speech, and since these same groups already alternate, in formal conversation, their use of [ɑ] and [ɔ̃] when variable (a)-1 is in a final closed syllable, the open back unrounded variety [ɑ] is likely to arrive at a certain degree of co-occurrence with the open or half-open back rounded one in later stages in all environments. There are at least good indications that the variety

[ɑ] is in the process of becoming more and more widely recognized (cf. young, less educated informants who show a pattern of behaviour very different from that of their older counterparts in more formal styles of speech).

The observation of data on variable (a)-1 has shown that, for each group observed, the frequency in the realization of [ɑ] rose in a final closed syllable and that each group followed the same pattern of stylistic variation. These factors demonstrate that the rule which makes possible the backing and rounding of [ɑ] is not simply a summary of the performance of particular groups. On the contrary, the phonological environment and the formality of the situation constitute general constraints reflecting the linguistic system of all Trifluvians interviewed.

The variability present in the data demonstrates that a "variable rule" (1) operates in the application of the rule [ɑ] → ⟨[ɔ]⟩. The output frequencies of this rule have been given in the various tables and diagrams and have served to indicate the proportional responses each group gave to [ɑ] in different phonological environments and styles of speech.

It is important to retain the phonological and stylistic constraints as factors in a variable rule model, since, following Cedergren and Sankoff's treatment, each of the variable constraints makes an independent contribution to the probability of the rule applying for any given sample. The model of Cedergren and Sankoff is founded on the hypothesis that the variable constraints are independent, and that each of them contributes to the probability of the rule irrespective

(1) For a variable rule treatment, see Labov, (1969a). However, for a more complete formulation of variable rules, see: H.Cedergren and D.Sankoff, (1974).

of the other constraints present. As has been seen in the various tables, each phonological environment, styles of speech, and social factors contribute in varying degrees to the application of the rule. Thus, in order to account for all these constraints, the following rules may be given.

Formal conversation

1. categorical rule : $[a] \rightarrow [ɔ]$ / — $\left. \begin{array}{l} \text{final free position} \\ \text{non-final position} \end{array} \right\}$
2. Variable rule: $[a:] \rightarrow \langle [ɔ:] \rangle$ / — $\left. \begin{array}{l} \text{final closed position} \\ \text{f (education, occupation, sex)} \end{array} \right\}$
(1)

Careful styles

- Variable rule $[a(:)] \rightarrow \langle [ɔ(:)] \rangle$ / — $\left. \begin{array}{l} \text{final free position} \\ \text{final closed position} \\ \text{non-final position} \end{array} \right\}$
f (education, occupation, sex, age)

Generally

- Variable rule $[a(:)] \rightarrow \langle [ɔ(:)] \rangle$ / — $\left. \begin{array}{l} \text{final free position} \\ \text{final closed position} \\ \text{non-final position} \end{array} \right\}$
f (phonological environment, style, education, occupation, sex, age)

(1) f means : function of

2.3 The study of archaic phonetic features

Thus far, the implications of various patterns of behaviour towards variable (a)-1 have been dealt with. In sections 2.1.1 to 2.1.4, other phonological variables have been described. Among the possible realizations which could affect any of the phonemes mentioned in these sections, there were those which referred to archaic pronunciations v. more common French forms. These archaic pronunciations concern variables (a),(è),(eu),(g),(ch), and the sociological values implied in their usage will now be considered.

2.3.1 Historical notes

Before dealing in more detail with the social distribution of these variables, some historical notes will be given in order to review the origins of some features of Québec French pronunciation. In fact, like all French dialects, Québec French has the overall characteristics of the general French phonetic system. However, there are also some differences between general French and Québec French, and some of them may find their explanation in history, while others are innovations.

The variables concerned here all have their origin in the speech of certain regions of France. French immigration to North America started in the 17th century and brought settlers of different origins. Though predominantly coming from the North and Northwest of France, the cultural and linguistic

customs of the settlers were not uniform. These settled down not according to their different origins, but freely throughout the colony, so that after a short period of time, the linguistic differences were sufficiently reduced to make communication possible. As it happens in linguistic contact situations, the common speech pattern developed in Québec was a product of a reduction of forms to the common forms shared by the majority of contributing dialects, and of a general acceptance of a prestige dialect, in this case French as spoken by the clergy, administration, etc.

Late 17th century Québec French can be assumed to have resembled very closely the standard French spoken by a minority group in France (1). The difference which exists nowadays between Québec French and Standard French is to be attributed to the forced isolation of Quebecers from their mother country after 1763. However, all forms nowadays found in Québec French are shared by the whole community, even though most of them will not be used by every speaker in the same way.

2.3.1.1 Variable (a)

A diphthong /ei/ in French, which later evolved to /oi/, finally becoming /wa/ , derived from a close /e/ (itself originating from è and ĩ), in a final free position, and from latin close e + yod (2). At the same time, another value was attributed to the diphthong /oi/, namely [wɛ̃] or [wẽ] . Examples of such pronunciation were mainly found in

(1) cf. E.Brent, (1971), p.110

(2) The information given here is to be found in N.Juneau, (1972), and in J.Gilliéron and E.Edmont, (1902-1910).

words ending in -oir (e.g. bouilloire, boire, avoir, etc.), and in words like soixante.

e.g. "souesante" in Archives du Couvent des Ursulines de Québec, l.c., p.66, 1677-78. (1)

The pronunciation [wɛ, we] from the spelling -oi was maintained in general French until the 18th century, even though the pronunciation [wa] could be found in Paris from the 13th century. Thus, it is not surprising to find both pronunciations in Québec French. The use of [wɛ, we] will appear in the spelling -oir (e.g. mâchoire, avoir, boire, etc.), and in words like toi, moi, il boit, froid, droit.

No occurrences of [wɛ, we] were found in a non-final position in the speech samples recorded. It seems as though this archaic pronunciation has disappeared in this environment. However, it is still probably possible to find realizations such as [swesã:t] soixante in everyday speech. The use of [wɛ, we] in this environment is limited to such a small number of lexical items that no examples were found in the samples studied. The pronunciations used to realize the spelling -oi are various. As previously indicated, a half-open front unrounded vowel, originating from dialects of France, may be used mainly in a final closed and final free position. Apart from this realization, the spelling -oi is realized in various ways along the low axis of the phonetic trapezium, i.e. [wa, wã, wä, wA, wã, wa, wö, wo]. The glide /w/ may have a certain effect on the vowel, in that this latter is usually more or less backed and labialized.

(1) M. Juneau, (1972), p.60

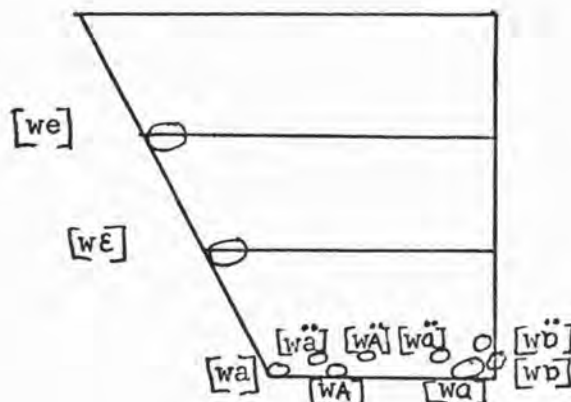

As shown on the trapezium some realizations may go as far as an open back rounded vowel. This realization affects the vowel when found in a non-final, final closed and final free position. It might be explained by the effect of /w/ on the vowel, but since no acoustic tests have been carried out to account for such a phenomenon, and since such distinctions are hard to establish on purely auditory grounds, the only possibility left is to mention that such a feature is possible.

In addition, very few informants used the variety [wö, wɔ]. What is interesting to note is that those who used it were often users of the half-open front unrounded variant also. Some informants therefore alternate their pronunciation by using all three possible sets of pronunciations in a careful speech style.

e.g. inf.29 [mɔ̃ʷ] wö] Mâchoire, [bulwö:r] bouilloire
 [abrœ vwö:r] abreuvoir, [mu] wÄ] mouchoir
 [nwÄ] noir [swɛ:r] soir

inf.30 [mu] wü] mouchoir, [swÄ] soir
 [abrœ vwÄ:] abreuvoir, [mɔ̃ʷ] wɛ] mâchoire
 [bujwɛ] bouilloire [nwɛ] noir

The use of an open back rounded vowel is certainly not very common. Another possible explanation would be related to a phenomenon of hypercorrection. Since this variety is used mainly in careful style, and since especially speakers who used [wɛ,we] used also [wʊ,wɔ], the reason of such a backing and rounding of the phoneme could be that, in order to obtain the feature associated with "good" speech, namely [wa,wa], these speakers would overcorrect [wɛ,we] and fall to [wɔ].

The use of [wɔ] is however only sporadic and sometimes hard to determine because of the preceding glide. Therefore, it is not possible at the moment to draw conclusions as to the possible effect of /w/ on the vowel or on the phenomenon of hypercorrection. Nevertheless, it is still worth noting that such features are possible.

The study of variable (a) will therefore concern the co-variation of the archaic pronunciation [wɛ,we] with the more common French form [wa]. Usually, [wɛ] is to be expected before a consonant, while [we] will occur mainly in a final position, though it is possible to hear [mirwe:r] miroir. Most of the time, however, [wɛ] will be used for [swɛ:r, nwɛ:r] soir, noir, etc., and [we] for [mwe, i bwe] moi, il boit, etc. It should be noted here, that utilization of [we] instead of [wa,wa] does not affect all lexical items. For example, the words voix, toit, roi, foi, loi, doigt, croix will always be realized as an open front to back unrounded vowel, i.e. [wa...wa]. No occurrences of [we] may affect these lexical items. Therefore, the study of co-variation of [wɛ] and [wa] will concern only the lexical items where both pronunciations can be used to realize them.

As noted by Juneau (1), the pronunciation wè or wé is one of the archaic features which is most implanted in popular speech. In using it, people stay "faithful" to the archaic French pronunciation (2).

2.3.1.2 - Variable (è)

The features associated with an archaic type of pronunciation for variable (è) are the opening of the half-open front unrounded /ɛ / into [æ] , when the phoneme occurs in the sequence /ɛ + r + C / and in a final position, and also the closing of /ɛ / into [e] when the phoneme is in a final closed syllable checked by /r/. In these environments, words like serviette, paix, père, could be pronounced [særvjɛt, pæ, pe:r] .

The opening of /ɛ / into [æ] before /r+C/ has a popular origin and was important mostly in Middle Old French. This feature was still widely spread in popular Parisian French in the 17th century. This Parisian French pronunciation has had a strong influence on Québec French, together with forms of speech coming from Poitou, the Charentes area, and Centre of France, where the opening of /ɛ / into [æ] before /r+C/ was often used. This pronunciation was common in Old Québec French, as many examples can be found in Archives.

e.g. serviette : " 17 sarviette" Documents de la Prevôté de Québec, vol.17, 1750, Québec. (3)

(1) M.Juneau, (1972), p.64

(2) J.D.Gendron, (1966), pp.82-83

(3) M.Juneau, (1972), p.40; see generally, pp.39-46

The opening of /ɛ / in a final position is a more common feature in present day Québec French. This pronunciation also has its origin in the period of immigration of French people to "New France". This pronunciation was in fact typical of the popular Parisian French of the 17th century. To this should also be added a possible influence of the Western and Northwestern regions of France. The 94th map of the ALF of tu avais notes a final a in certain areas of Northwestern France, such as Côtes-du-Nord, l'Ile-et-Vilaine, la Mayenne and Vendée. On the map 807 j'en mangerais, and the map 143 il buvait, a appears in certain areas of the Deux-Sèvres and of Charente (1).

This opening of /ɛ / into [æ] in the two environments described, is easily perceptible auditorily. Acoustic tests carried out by Gendron indicate that this opening gives a segment nearer cardinal 4 than cardinal 3 (2). It will be noted here as [æ] .

The remaining archaic feature affecting the realization of /ɛ / involves a closing of the phoneme into [e], when it is followed by /r/ in a final closed syllable. Gendron notes that this pronunciation also comes from archaic forms of speech and that it is nowadays rejected or considered as vulgar by educated people (3).

Thus, the opening and closing of /ɛ / in specific environments can be said to be features which have their origin in different dialects, mostly those of the 17th century, period of the French settlement.

(1) M. Juneau, (1972), p.50; J.D. Gendron, (1966), pp.65-66

(2) J.D. Gendron, (1966), p.69

(3) Id., p.61

2.3.1.3 Variable (eu)

The half-open front rounded phoneme /œ/, like its unrounded counterpart /ɛ/, may be closed, thus nearing [ø], when placed in a final closed position checked by /r/. Words like peur could therefore have the phonetic realization [pœ:r] .

This phenomenon has not been accounted for either by Gendron, Juneau or most of other writers on Québec French phonology. It is true that this variety is rarely used nowadays, especially when people focus their attention on pronunciation. Nevertheless, it is still present in the speech of some informants and its origin could easily be the same as that accounting for the closing of /ɛ+r/ into [e̞].

In French, there are three half-close vowels, i.e. /e, ø, o/, and three half-open vowels, i.e. /ɛ, œ, ɔ/. The front-back and rounded-unrounded contrasts are more important in differentiating these phonemes, than the close-open contrast. Emphasizing this, is the fact that half-open segments may be realized as half-close ones, as in père [pe:r] and peur [pœ:r] without creating any semantic confusion, whereas père would never be realized as peur or port, i.e. changing its front and unrounded features into rounded and back ones. Only pronunciations involving tongue height features are possible.

A change such as half-open vowels going to half-close vowels is not frequent in the speech of Trifluvians. It comes from an archaic type of pronunciation, as previously stated, and is probably one of the archaic features which is regressing more in present day Trois-Rivières French. Nevertheless,

it will be interesting to observe speakers' behaviour in respect of these features compared with other more common ones, such as the use of [we] in the personal pronouns toi, moi.

2.3.1.4 Variables (g) and (ch).

The realizations of the two palato-alveolar fricatives have been described in section 2.1.4 . It will therefore be sufficient here to repeat that the velarization of both segments, i.e. /ʒ,ʃ/ → [ɣ,x̠] , or the glottalization of /ʒ / into [h̠] can occur in initial, medial between two vowels, and final positions. These pronunciations have their origin in some areas of France, such as Poitou, and the North of the Gironde.

2.3.2 Archaic phonetic features viewed as stereotypes.

Different variables may exhibit different behaviour with respect to both their social and stylistic distribution. These differences mainly concern the categorical versus the variable nature of the social and stylistic markings involved.

Labov distinguishes between "stereotypes", "markers", and "indicators". While linguistic indicators are involved in social distribution only, linguistic markers show both social and stylistic stratification. These seem most of the time to

stem from social awareness. Stereotypes, on the other hand, "which have risen to full social consciousness, may represent older cases of variation which may in fact have gone to completion; or they may actually represent stable oppositions of linguistic forms supported by two opposing sets of underlying social values" (1).

The use of archaic phonetic features, such as [mwe] instead of [mwa] moi, [h mā:h] instead of [ʒ mā:ʒ] je mange, corresponds to this type of linguistic feature, referred to as a linguistic stereotype by Labov. As will be seen later, it represents stable oppositions between more common French forms and archaic ones, themselves supported by two different sets of social values. These are underlined by the subjective attitudes of groups towards both sets of forms.

The social value attributed to archaic phonetic features has risen to full social consciousness. This point is illustrated by the fact that when informants were asked if they noticed any differences in the speech of different members of the community, some answered positively by pointing out some of the following features.

Many of these informants gave examples concerning the personal pronouns moi, toi, saying that less educated members of the community would use [mwe,twe] as opposed to their pronunciation, which they felt more correct, namely [mwa,twa]. Others referred to the use of [x] and [h] instead of [ʃ] and [ʒ] by people they referred to as less educated. Other informants referred to the use of an open segment [æ] instead of /ɛ/.

(1) W.Labov, (1970), p.205

These phonetic features, especially the closing of /wa/ into [ɛ or ɛ̃], and opening of /ɛ/ into [æ] are the phonetic features which are more widely in use in modern Trois-Rivières French. It is therefore not surprising to find informants referring to these rather than referring to less widely used forms such as [pe:r] père, [pø:r] peur, etc.

Not only did the more educated informants seem aware of the values attached to such forms, but also the less educated speakers. A shoemaker, informant M.3.4, was conscious of the forms such as [æ] instead of /ɛ/. Indeed, he mentioned, that in everyday life, he would say [d^{zy} læ] du lait, rather than [d^{zy} lɛ], for example. On the other hand, when talking in public or with strangers, he admitted to correcting his language by pronouncing words with /ɛ/ rather than with [æ].

Another informant referred to the personal pronouns moi and toi and said:

[jã de mwe / pⁱja de twe / ʃ nã pø äbɥt^sɥë ä sɔ / se py to
mwa pɪtwã]

"Il y a des moé, puis des toé. On n'est pas habitué à ça. C'est plutôt moi, puis toi".

What is interesting to note is that this informant was very aware of a value attributed to such a pronunciation. He saw it as something to be rejected. This was his conscious attitude towards this archaic feature. However, when he shifted to a less formal form of speech, he himself used [mwe] instead of [mwa].

e.g. [mwe/ hëm otã lä lã.g / la lã.g bjë päfle]

"Moi, j'aime autant la langue, la langue bien parlée".

What the case of this informant shows, is that users

of forms such as [mwe,twe] moi,toi will use this variety when speaking spontaneously, probably within their peer group. However, their conscious attitude towards such a form is the opposite of that which they use. They view it as incorrect and to be rejected. These speakers are aware of the social significance attributed to stigmatized forms, which are discouraged by the educational institutions.

An awareness of forms rejected by educational institutions may nevertheless lead to different attitudes. They may be felt as erroneous and therefore to be rejected; but even though regarded as incorrect, they may be consciously retained in the speech of some informants. The answer of a 20 year old female factory worker illustrates this point.

[sa depã WI / kõm kã kõ võ a lekɔl/ u kekã ʃo:z damɛ^r:m/
 ʃ sɛrmaʃke bokv / ʃ ne tapɔ^r de zo^t / mã sãb kɪ. davɛɛ
 avwɛ: dla ʒust^sis pʊr sɔ/ bẽ svã sa depã dla parwɛ:s
 vs kã tɛ^y RE:s / n^y zo:t ã tɛ^y kɔ / kã mwe / kã ʒalɛ:
 ekɔl/ ʒe^te bẽ mi d ko^te pʊ sɔ / ʒRESTÈ nɔ^tra dam dla pɛ /
 ʃparlæ pɔ bjẽ kõm le zo^t / ʒe^te elve d mɛ^r:m / ʃpʊvæ
 pɔ sɔ^rtɛ^r de mwa/ pi de twã / ʒe ʒamẽ dzi^z sɔ / dɔⁿa Rjẽ dã
 s fɔ^rse]

"Ca dépend, oui. Comme quand on va à l'école, ou quelque chose de même, on se fait remarquer beaucoup. On est à part des autres. Il me semble qu'il devrait avoir de la justice pour ça. Bien souvent, ça dépend de la paroisse où ce que tu restes. Nous autres, en tout cas, quand moi, quand j'allais à l'école, j'ai été bien mise de côté pour ça. Je restais (dans) Notre-Dame-de-la-Paix; je ne parlais pas bien comme les autres. J'ai été élevée de même. Je ne pouvais pas sortir des moi puis des toi. Je n'ai jamais dis ça. (Ca) ne donne rien de se forcer".

This young girl is very well aware that, by using forms, such as [mwe] instead of [mwa], she has been rejected

at school. She comes from a very poor area of Trois-Rivières, and through her speech has been recognized as belonging to a less favoured group. However, even though aware of more prestigious forms such as [mwa], she consciously keeps in her speech the less favoured [mwe]. As she says: "Ca ne donne rien de se forcer". In other words, she feels more herself, more natural, when using certain features which are rejected by others. She also feels that there should be a more tolerant attitude in this regard, i.e. that people should be allowed to speak in their own way, without being rejected socially for doing so.

The case of this young girl reflects the presence of different social values towards language within a society.

Educational institutions, other institutions such as radio, television, etc., avoid the use of archaic phonetic features now associated with rural and less educated speech. Certain social groups follow this tendency by consistently rejecting these forms of speech.

Other groups also reject these forms consciously, by trying to avoid them in careful speech, although they may be present in everyday speech.

Whatever the attitude towards such linguistic stereotypes, it can be seen that in a social context members of a community may be set apart, by the mere fact of their belonging to a particular social group, this being reflected by their language. Linguistic stereotypes, such as those involved in the linguistic variables here under study, are certainly the linguistic features which are more likely to identify a speaker as being a member of a particular social group.

As has been seen through the informants, all are aware of the negative social value attributed to some archaic linguistic features.

Those who represent the category of speakers using these "negative" linguistic markers are likely to be the most linguistically insecure. They know that their use of such features is not highly regarded socially and they will therefore be expected to try to avoid them in a formal style of speech. However, others, such as the young girl, might react strongly to such social pressure, by consciously using these features, probably in order to show that they belong to a particular group, and that they have the right, socially, to be so.

As the shoemaker puts it:

[nɔ̃ sil mɔ̃:d palræ̃ tut avék œ̃ n aksãply pwët^sy / palræ̃
kôm ø zo• / kĕssjɔ̃ dãturã:x]

"Non, si le monde parlerait tout avec un accent plus pointu, je parlerais comme eux autres. Question d'entourage".

This man is very conscious of what the use of archaic phonetic features may represent socially. However, he is also conscious of the values of his own neighbourhood and peer group, so that he retains the use of these features because his own group does so and does not talk with this "accent", i.e. the one not customary in his own group, which he calls: "plus pointu". He does not feel the need systematically to correct his everyday speech, since it would be artificial for him to do so, his own peer group not recognizing such a need. It is a question of group loyalty.

Thus far, it has been primarily the less educated

informants who have been considered, with regard to their subjective attitudes towards linguistic stereotypes. It might be interesting here to focus on attitudes of younger, more educated informants. Older informants in this group, generally aged 30 years and over, showed a very negative attitude towards forms represented by linguistic stereotypes. They viewed them as features to be completely rejected from the language.

Younger informants, on the contrary, were far less categorical in their judgement. They felt that these forms were part of Québec French, and that people who used them were right to do so. For them, this "popular" language was far more creative and lively than a more Standard French, which they felt was not really natural for many Quebecers, but rather a learned variety.

Some of these young informants admitted that they sometimes used forms, such as [mwe], etc., when they were in particular contexts. They saw themselves as being able to adapt their language according to the social group in which they moved.

Two young professional men particularly emphasized this fact. They said that they would swear with people who swore, and that they would use forms such as [mwe,twe], etc., when with people using these forms. They added that, by doing so, they could not be accused of snobbery, by using too careful speech.

Young, more educated informants might look at forms associated with "good" speech as being irrelevant in certain contexts. This attitude allows them to select archaic phonetic

features when it is felt appropriate to do so. As one of these informants puts it:

[ʃek de fwä i maʁi:v de dʒiːb de mo kɔ̃ə / kɔ̃m mwa / ʒvɔ dʒiː
kɔ̃m mwe / pi mɔ̃ frɛːb se mɔ̃ frɛːb / pi sã tʁo savwaː / me
sa depã ẽ pɔ̃ dʒy miljɔ̃ / ə dʒiːzɔ̃ kse sã tʁo savwaː ʁ ɔ̃
sadaɓt ase fasilnã / ə / a œ n aksã v dʒy fasɔ̃ d pãble
kjegzɪs dãzœ mijɔ̃]

" Je sais que des fois, il m'arrive de dire des mots comme: comme moi, je vais dire comme moé, puis mon frère, c'est mon frère, puis cela sans trop savoir. Mais ça dépend un peu du milieu. Disons que, sans trop savoir, on s'adapte assez facilement à un accent, ou d'une façon de parler, qui existe dans un milieu".

The basic attitude of such informants is very close to the one expressed by the shoemaker. Both attitudes recognize forms associated with "good" speech, and also forms related to a more casual form of speech. Choice between both forms is a question of surroundings and context.

Speakers, like the shoemaker, are expected to select these archaic phonetic forms more often than the more educated informants, since they move in a group which uses such forms, whereas the more educated interact most of the time with speakers who reject them.

The social attitudes towards linguistic stereotypes can be summed up in four main categories:

- 1- some speakers consider them as a negative marker in all contexts (mainly older, more educated informants);
- 2- others do not admit them, on a conscious level, but nevertheless may use them in everyday speech (probably older, less educated informants);

3- some recognize these features as carrying a negative value but nevertheless use them consciously in order to react against social pressure (more likely younger, less educated informants);

4- and finally, speakers who usually do not use these features could also select them when placed in particular social contexts (probably younger, more educated informants).

2.3.3 Co-variation of linguistic stereotypes and sociological parameters.

Thus far, we have dealt with historical notes and different social attitudes towards archaic phonetic features. It remains to consider the behaviour of different groups towards these linguistic features, in order to establish more precisely their social and stylistic distribution.

2.3.3.1 Differentiation by education and sex

Table 13 gives the proportional responses to the sounds having their origin in old French dialects, by education, sex and style. Two styles of speech will be considered in the treatment of these variables, namely careful style and formal conversation, since not enough examples were present in reading style to represent all of the variables. The two styles considered are nevertheless sufficiently differentiated in their formal versus less formal characteristics,

to enable a fair study of these variables in different speech situations.

Environments	styles	ed.1		ed.2		ed.3		ed.4	
		M	F	M	F	M	F	M	F
/ɛ+r+C/ → æ -(ɛ)#	CS	3%	0%	1%	0%	15%	16%	29%	12%
	FC	5%	0%	20%	4%	76%	75%	83%	80%
-(wɑ)+r# → [we:]	CS	11%	0%	1%	1%	83%	77%	40%	49%
	FC	0%	0%	0%	0%	90%	90%	90%	85%
-(wɑ)# → [we]	CS	0%	0%	0%	0%	12%	50%	15%	28%
	FC	0%	0%	0%	0%	95%	83%	32%	64%
-v(ɜ)v- #(ɜ)- → [h] -(ɜ)#	CS	0%	0%	3%	0%	17%	0%	28%	0%
	FC	.8%	0%	7%	0%	33%	0%	54%	5%
-v(ɪ)v- #(ɪ)- → [x] -(ɪ)#	CS	0%	0%	0%	0%	0%	0%	8%	0%
	FC	0%	0%	.4%	0%	16%	0%	35%	.8%
-(ɛ)+r# → [e:]	CS	0%	0%	0%	0%	9%	6%	6%	0%
	FC	0%	0%	0%	0%	51%	33%	46%	7%
-(œ)+r# → [œ:]	CS	0%	0%	7%	0%	19%	0%	10%	0%
	FC	0%	0%	6%	0%	10%	0%	25%	0%

Table 13: Percentages of responses to 7 archaic phonetic features by education, sex and style.

As the table illustrates, use of archaic phonetic features is strongly correlated to sociological parameters. The use of these pronunciations has almost disappeared from

the speech of more educated informants, at least in the interview situation, while they remain at a relatively high level of usage in the case of less educated speakers. Where these varieties occur in the speech of more educated members of the sample, it is generally due to a small number of informants.

Table 13 is complex, in that it gives the results of various phonetic features. However, it can clearly be seen that the most important feature in differentiating groups is the education factor, i.e. when those having 10 or more years of schooling are compared with those having 9 or fewer years attendance at school.

Statistically speaking, Chi Square and Exact Value test give the strongest evidence against the assumption that each group will behave in the same way towards these variants, when the two main educational groups are compared. These tests of significance apply in fact for each phonetic variable studied, in differentiating both educational groups.

The results clearly represent what was referred to as linguistic stereotypes by Labov, in that the phonetic features concerned "represent stable oppositions of linguistic forms supported by two opposing sets of underlying social values" (1). These linguistic features have almost disappeared from the speech of more educated informants, whereas they are retained in the speech of less educated ones. Two opposite patterns of behaviour are present.

From the results it can safely be assumed that a high selection of one or more archaic phonetic features will

(1) W.Labov, (1970), p.205

be largely dependent on the educational level of the speakers.

'This is not to say that more educated members of the community would never select these features. As has been seen in the case of some young, more educated informants (cf. section 2.3.2), selection of some of these variants could also be possible in specific social contexts. In fact, any one member of the speech community could select one or more archaic variants, though not necessarily, but their use would involve degrees of occurrence in differentiating speakers.

Since the interview situation provided no examples of strong emotions, such as those provoked by anger, joy, etc., almost no occurrences of archaic features appeared in the speech of more educated speakers. The domains where such features would be more likely to occur in the speech of these informants will have to be determined hypothetically. They would probably be domains where spontaneous interaction between speakers is favoured, and situations where strong emotions are likely to occur, such as in discussions about politics, etc.

There are sufficient indications in the recorded speech sample to suggest that some archaic phonetic features are present in the speech of more educated informants, although at a very low level of occurrence, thus permitting the assumption that there could be other linguistic and social situations, in which another value attributed to these features would appear. In the course of an interview, one cannot expect to find the "vernacular" used. No matter how natural the speaker is, it can always be assumed that he has a more casual speech, which he uses when he argues or jokes with friends, etc.

It would be interesting to observe the behaviour of speakers towards linguistic stereotypes in less formal situations. Another value could appear, namely one which would recognize the use of stereotypes as a means to reinforce emotions. If a father is exhausted by a noisy child, for example, he might very well say: [faerm twe] ferme-toi, instead of using a more common form [færm twa] to render his command more effective.

The assumption that domains could exist, in which selection of linguistic stereotypes would increase not only by less educated speakers, but also by more educated ones, is here hypothetical. Nevertheless, native knowledge of Trois-Rivières French, enables one to assume that a study of these phonetic features in less formal situations would provide interesting indications of the whole range of values present in them. A study of this kind could make use of approaches such as those used by Blom and Gumperz, by Labov, Cohen et al., etc.(1).

Now that the limitations of the linguistic situation created by the one-to-one interaction of subject and interviewer have been determined and that other possible ways of studying linguistic features, especially those which have risen to full social awareness, have been focused upon, the data obtained in the type of interview conducted will be considered further.

(1) In Blom and Gumperz's work, (1972), the data were obtained through recorded sessions with natural groups. Labov, Cohen, et al., (1968), used group observations as well as personal interviews with members of these groups to collect their data in South Central Harlem.

2.3.3.1.1 Linguistic stereotypes and more educated informants

Each variable cannot be treated in exactly the same way. In fact, there is no reason to assume that each stigmatized feature is rejected to the same degree by the various groups.

As shown by table 13, some features occur in the speech of more educated informants, whereas others are absent. The one which is most often used is the opening of /ɛ/ into [æ], and is mainly to be observed in the older male group in formal conversation. In this particular style, opening of the vocalic segment mainly affects verbs ending in /ɛ/, i.e. verbs in the imperfect, conditional, etc. tenses. This is the only stigmatized feature in which an interesting difference between more educated speakers is to be seen. Older men in this group have a more conservative attitude towards this feature, in that they use a significantly higher percentage of the open variety than women and younger informants. This variety is also the only one where almost all groups used a certain amount of a linguistic stereotype in formal conversation, and where style shifting is to be observed.

There is also a certain sex differentiation present. Younger women never used, in either style, any of the linguistic stereotypes. Older women used [æ] in formal conversation and [wɛ:] in careful style only infrequently.

Younger men used [æ], [wɛ:] in careful style and [h] in formal conversation occasionally. Older men used [æ] the most frequently; some had [wɛ:] in careful style, a limited usage of [h] and [x] in formal conversation and finally the occasional [œ:]

Although all occurrences of linguistic stigmatized features by more educated informants are at a very low level, the mere fact of their presence suggests the possibility of a higher percentage of usage of some of these stereotypes in other stylistic contexts.

Another indication which underlines this possibility is the use of [wɛ:] in careful style by three groups. The use of a stereotype in careful style rather than in formal conversation seems to contradict the opposition formal v. less formal styles of speech, where one would expect rather higher usage of [wɛ:] in formal conversation, as in the case of less educated informants.

This apparent contradiction is however easily explained. Usage of [wɛ:] by more educated informants affects only one lexical item in careful style. This lexical element occurred in the context of an idiom, where the informants had to say Il fait noir comme chez le diable. The pronunciation of this idiom was for some informants: [i fɛ nwɛ:r kɔm ʃel dʒa:b] , as was the case for 11 of the 17 informants with 9 or fewer years of schooling.

This very specific context, given by an idiom, explains the use of [wɛ:] by some of the more educated informants in careful style. The idiom has probably been learned with its archaic pronunciation features, and has been kept unchanged. These informants have probably felt no need to correct the pronunciation of noir in this particular context, since the fact of saying an idiom in its archaic phonetic form was regarded as normal.

The context, illustrated by an idiom, provides a good indication that there might be cases where selection of

linguistic stereotypes could occur at a higher level by more educated informants, if other contextual styles and other inter-relationships could be determined and studied. The case of an idiom is one among many where such behaviour could be expected. In this context in fact, less attention is likely to be focused on pronunciation, and moreover, the meaning carried through it might be thought as being better conveyed if the pronunciation reflected it also.

Nevertheless, the attitude towards linguistic stereotypes by more educated informants is very clearly underlined by their behaviour in the interview situation. The use of such features, when present, is at a very low level, and most of these features have disappeared in the speech of these informants. This is a case where subjective attitudes towards linguistic features are perfectly represented by linguistic behaviour.

2.3.3.1.2 Linguistic stereotypes and less educated informants

Table 13 shows that each stigmatized form is not rejected or used to the same degree by these informants, in that the co-variation with sociological parameters, such as sex and age, is not the same for each stigmatized feature.

Sex differentiation

If the behaviour of men and women is considered, differences occur between sex groups. A certain discrepancy is to be seen for most of the variables. The only cases where

the differences between men and women are not significant concern the use of [æ] and [wɛ:].

Elsewhere an interesting discrepancy occurs. For most of the remaining variables, men use significantly higher percentages of the stigmatized forms than women. Whereas the use of features such as [h,x,ɔ:] has almost disappeared in the speech of women, it is still largely present in the speech of men (note that the 5% [h] and .8% [x] present for older women in formal conversation is based on the evidence of 1 informant only). Also in the usage of [e:], even where young women used a relatively high percentage of this variety in formal conversation, a significant difference is to be seen, in that women used this variety less frequently than their male counterparts.

The pattern emerging from the behaviour of sex groups towards linguistic stereotypes, such as [h,x,ɔ:,e:], is the one which might be expected. Indeed, women are usually more likely to be sensitive to prestige features than men (1). It is therefore not surprising to find women using these features less than men. However, it should be added here that features, such as [h] and [x], are also associated with men's speech. Indeed, not only have these variants risen to a level of social consciousness, but also they have another connotation or value in the mind of the speakers, namely that these are features usually used by men and not by women. This value has been underlined in the answers of four women. It is moreover emphasized by the fact that only 1 woman used these two varieties, and that generally, [h] and [x] are used by men (also more educated ones) and not by women.

(1) cf. P.Trudgill, (1974), pp.93-95 and W.Labov,(1970),p. 197, where women, usually, show greater awareness of prestige patterns than men.

The pattern offered by variables (g),(ch),(è) and (eu) is however not the same when the remaining variables are considered.

Women and men behave in the same way where use of [æ] and [wɛ:] is concerned. Moreover, women use [we] much more than men, except for younger women who, in formal conversation, used this feature slightly less frequently than their male counterparts. Where women would be expected to make more restricted use of the features associated with "old-fashioned" and even "uneducated" speech, they display the opposite pattern of behaviour towards certain features, by using either the same percentage as men, or an even higher percentage, as in the case of -oi in a final free syllable.

To allow a feasible explanation for such behaviour, variable (a)-1 will be considered again. If this variable is considered in a final free position, where [ɔ] was more often used, the degree of co-variation of [a] and [ɔ] in careful style, according to a sex and educational grouping, gives the following results:

Men (with 13 or more years of schooling)	: 45% usage of [ɔ]
Women (id.)	: 12%
Men (with 9 or fewer years of schooling)	: 100%
Women (id.)	: 93%

This table shows clearly that it is women of higher educational background who have the greatest awareness of the open back unrounded variety [a] .

Women of a lower educational level, on the other hand, do not display a behaviour pattern as significantly

different from that of their male counterparts as do women of a higher educational level. The evidence is therefore not clear, as to whether women of a lower education are, like women of a higher education, more sensitive than men to some social norms of speech (1).

In the case of variable (a)-1, as well as for the use of [æ], [wɛ:] and [wɛ̃], women of lower educational level use speech to identify themselves with their social group. This is marked by a pattern of behaviour similar to that of the men. Such behaviour can also be due to the fact that women, who do not work, stay more closely tied to their neighbourhood than men, who usually leave it for their work. The latter are therefore more liable to have more extensive contact with other speech forms, therefore using them more than women.

In conclusion, women seem more aware than men of forms which are generally less used in formal conversation. In fact, [h̃], [x̃], [e:] and [œ:] are the less widely used forms of all features by all groups. On the other hand, the archaic phonetic features which still hold a strong position in the less formal speech of men are used by women with the same frequency as men, and sometimes more often. Sex differentiation seems therefore to be dependent on the position each phonetic feature occupies within this educational group, and the study of the age parameter will help to clarify this differentiation.

(1) cf. W.Labov, (1970), p.197

Age differentiation

a) No linguistic change in progress

The linguistic features under study have been socially stigmatized as a mark of uneducated, or at least old-fashioned speech. If such features have no linguistic change in the social value they carry, a sociological distribution such as the following would be expected: members of higher educational groups would show no trace, or very little, of these features, whilst less educated speakers would use them extensively. Younger and older informants of this latter group would probably show a relatively similar degree of use of these features (1).

This is the case for [æ], where there is no significant discrepancy between younger and older less educated informants, and also for [wɛ:] in formal conversation.

However, for [wɛ:] in careful speech, [we] in both contextual styles, and [e:] in formal conversation, young informants use these archaic features significantly more often than their older counterparts.

The presence of an age gap for these linguistic features may be explained in terms of contact with the prestige forms and also by a subjective attitude towards these same features. As Labov writes, older speakers "would surpass the younger members of their own group, who would not have had as wide an exposure to the structure of social stratification, and its consequences" (2).

(1) cf. W.Labov, (1966a), pp.324 et seq.

(2) W.Labov, (1972b), p.134

Older informants, having mixed with other groups over a longer period of time, may be more sensitive to the social value attributed to archaic features than are the younger ones. This fact is emphasized by a sharp style shifting observed in older informants in the case of [wɛ:] . Thus, even in a static linguistic situation, some variations between age groups are possible.

On the other hand, the age differentiation present may be explained in terms of the subjective attitudes towards certain features found particularly amongst the young. For [wɛ] and [e:] young informants have a sharper style shifting than their older counterparts. From a similar percentage of usage in careful style, young informants are clearly differentiated from their older counterparts in formal conversation. The considerable reduction in their use of these two features in careful style demonstrates that young informants are as aware of prestige features as older members of their group.

Their higher usage in formal conversation may be due to the following factors:

- 1- having been in contact over a shorter period of time with linguistic features which carry more prestige, they have not yet acquired the habit of using these forms more widely in their everyday speech;
- 2- their subjective attitudes towards these features have led to a greater conscious use of these forms in their everyday speech.

The attitude of the 20 year old woman (cf. section 2.3.2) illustrates this assumption. The pattern of behaviour of this young woman is not meant to be extrapolated to that of all young, less educated informants. It is only mentioned in order to focus on another possible explanation.

The woman in question clearly stated that she did not want to correct her use of [mwe,twe] moi,toi, in that it was felt useless for her to do so. Other young informants might have the same feeling, since such usage is condemned by educational institutions, the mass media, etc., and since they too could be socially categorized because of their use of such forms. They may therefore deliberately react against this social pressure from above, by outdoing their older counterparts and by making frequent use of archaic features, i.e. by consciously retaining them in their everyday speech.

Whatever explanation may account for various patterns of behaviour towards these linguistic stereotypes, it remains obvious that not all of them are involved in the same process. As has been seen up to now, there are differences between age groups, in which young informants use some features more often than their older counterparts, even if no linguistic change seems to be present.

b) Linguistic change in progress

If, on the other hand, linguistic change in the social value attributed to some features is in progress, the effect of "increasing stigmatization", as Labov states, may be reversed. In fact, where no such change seems present, young and old informants are expected to behave in the same way, and if they do not, it is the older informants who are expected to show less usage of certain archaic features.

When there is change in progress, on the other hand, younger informants may be expected to make less frequent use of these features. This is the case for [h], [x], [œ:].

These features, as previously seen, have disappeared from the speech of all the women in the sample, with one exception. On the other hand, men still show a relatively high percentage of usage of these forms. There exists however an age differentiation between them, in that older speakers used these features more frequently than younger informants, and this applies in the two contextual styles.

Style shifting

Needless to say, users of stigmatized linguistic features are very well aware of other linguistic forms associated with "good" speech. In fact, all groups using archaic features displayed a very important style shifting when they moved to a more careful form of speech. When the amount of style shifting is related to the amount of linguistic insecurity, it appears clearly that less educated informants are the ones who are in this case insecure, since they make extensive use of those linguistic features which are socially considered as being more or less correct.

Knowledge of forms carrying more prestige however, is certainly part of the "communicative competence" (1) of these speakers, since they recognize these forms as being more appropriate to careful and "good" speech.

2.3.3.1.3 Summary

Usage of archaic phonetic features is a function of the educational level, sex, and age of the speaker.

(1) The notion of "communicative competence" has been elaborated by D.Hymes. cf. D.Hymes, (1971c).

Higher selection of any of the seven phonetic features studied is primarily dependent on the educational level of the speakers.

Sex can also account for some variation, in that higher selection of some phonetic features may be related to men, as seen in the case of [h], [x], [e:], and [œ:]. This sex differentiation is true for more educated and less educated informants.

Since usage of archaic phonetic features by more educated informants is so low, it need only be said that these informants are less likely to display variable patterns of behaviour towards these variables. In the type of speech styles elicited in the interview situation, more educated informants, and especially women, are likely to display a categorical non-selection of archaic linguistic features, rather than a variable selection of them. Some features, however, are more likely to be selected than others, as seen for usage of [æ].

Archaic phonetic features being associated socially with "uneducated" speech, higher selection and therefore variable behaviour is to be expected by less educated members of the community. This is exactly what is demonstrated by the results.

Behaviour of less educated speakers is also expected to be more complex, since in a variable pattern of behaviour, different relationships between sub-groups are more likely to emerge than when a categorical behaviour is displayed for almost all variables, as has been the case for more educated informants.

Considering again the groups represented by less educated speakers, the following assumptions can be made:

- 1- Linguistic change in the social value attributed to stigmatized features is to be observed when usage of [h], [x], and [œ:] is considered. Younger male speakers in fact used these forms significantly less than their older counterparts.
- 2- No linguistic change is to be observed in the use of [æ], [wɛ:], [we], and [e:], since in both contextual styles younger informants used these linguistic features at the same level, and sometimes at a higher one, than the older members of that group.
- 3- Apart from this age variation, a certain sex differentiation was present for some of these linguistic features.

What is interesting to note is that this sex differentiation can be closely related to the presence or absence of a linguistic change in progress.

As Trudgill says: "Speakers are more aware of the social significance of forms which are currently involved in linguistic change" (1). Since women often appear to lead in particular linguistic changes (2), in that they seem to be more sensitive to conflicting forms they hear from people of different ages within their own social group, it is not surprising to find that the forms where they show less usage of stigmatized features than men are exactly the ones which are in a process of linguistic change within their social group.

On the other hand, for features which are not involved in linguistic change, women behave in the same way as men, or overdo them by using these features more frequently

(1) P.Trudgill, (1974), p.99

(2) cf. P.Trudgill,(1974), p.95 and W.Labov,(1966a),p.568

than men (cf. use of [æ] , [wɛ:] , and [wɛ̄]).

This factor tends to demonstrate that women of a lower educational background are more likely to be sensitive to features which are involved in linguistic change within their own group than their male counterparts. Moreover, the pattern of behaviour of women towards these features is similar to that of the more educated informants, since they show a categorical non-selection of these forms in all styles (only 1 older woman used [h̄] and [x̄]).

4- Where variable behaviour is to be observed, an important style shifting takes place when informants move to more careful speech. It proves their knowledge of "prestige" features, although this knowledge is not present to the same degree for all groups (e.g. the case of [wɛ:] for younger informants).

5- Some stigmatized features hold stronger positions than others in the speech of the informants. The use of [æ] , [wɛ:] , and [wɛ̄] is still at a high level for every group, whereas [h̄] , [x̄] , and [ɔɛ:] seem to be represented only in masculine speech. [e:] is the only awkward case in that the more educated speakers never used it, and older less educated women almost never used it. Therefore, higher selection of this variable follows the order: younger women < older men < younger men.

Now that education, sex, and age have been considered, a brief study of the remaining sociological parameter will be presented.

2.3.3.2 Differentiation by occupation

' In order to present the differences existing between the three occupational groups, seven diagrams will be given. As shown by these diagrams, the differences are less striking, although it remains evident that manual workers are significantly differentiated in their behaviour towards each phonetic variable from white collar workers and professionals. If the differences seem less marked than those found between educational groups, it is merely due to a less refined grouping, i.e. that here no sex nor age subdivisions have been considered.

Nevertheless, the results obtained by comparing occupational groups confirm those found when educational, sex and age groups were considered.

[æ], [wɛ:], and [we] are obviously the stigmatized features most widely used among all stereotypes.

Professionals and white collar workers are not significantly differentiated from one another. Neither group displays any important style shifting, and their use of any stigmatized feature is restricted to a very low degree, although [æ] was selected more often. This feature probably has either a less negative value associated with it, or it is simply regressing at a lower rate.

The only feature which has not been selected at all by professionals and white collar workers is [we]. This probably shows that this feature is the one on which most attention is focused and which possibly carries the highest negative social value.

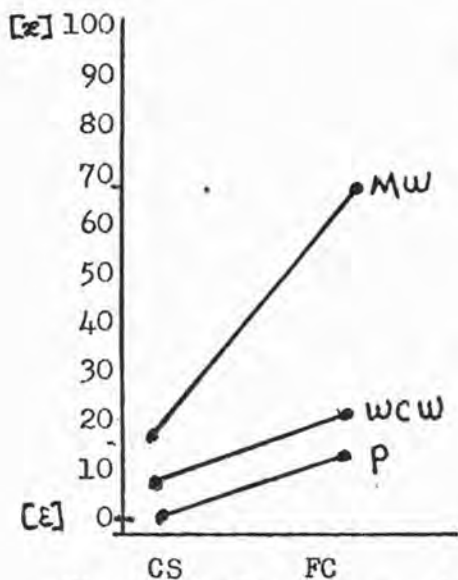

Fig. 7 % of responses to [æ] by occupation and style.

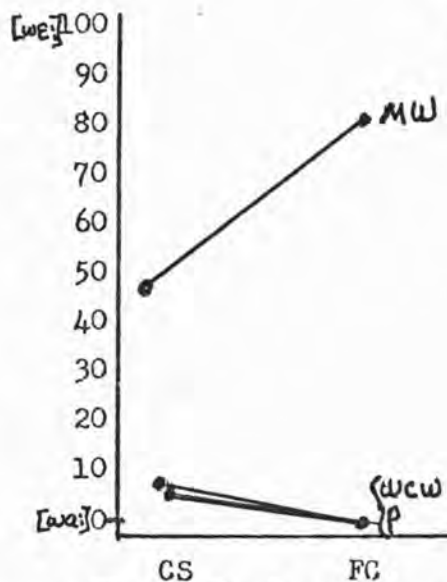

Fig. 8 % of responses to [we:] by occupation and style.

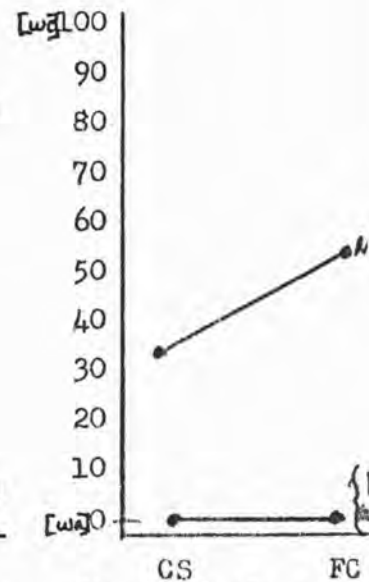

Fig. 9 % of responses to [we] by occupation and style.

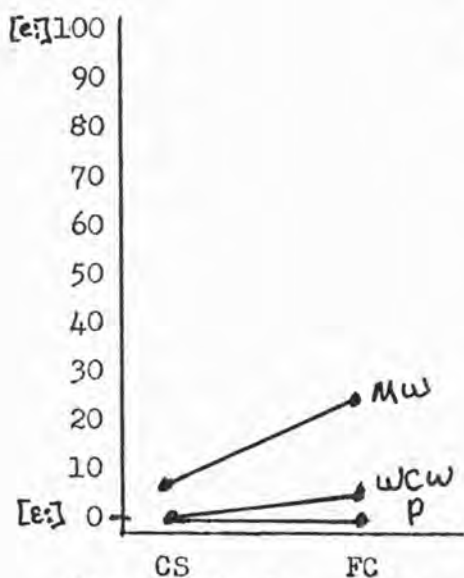

Fig. 10 % of responses to [e:] by occupation and style.

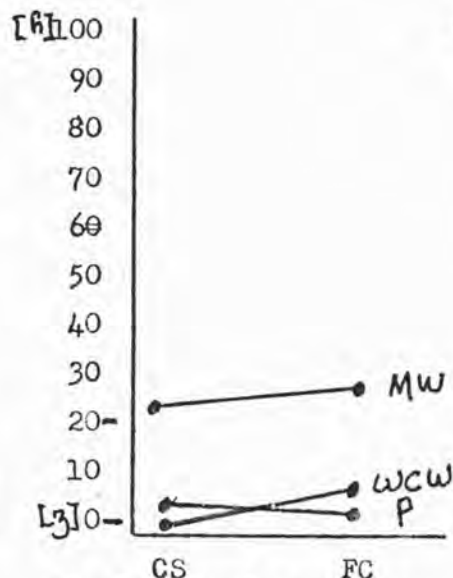

Fig. 11 % of responses to [h] by occupation and style.

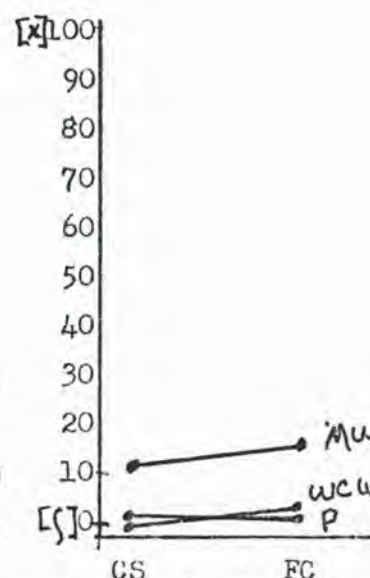

Fig. 12 % of responses to [x] by occupation and style.

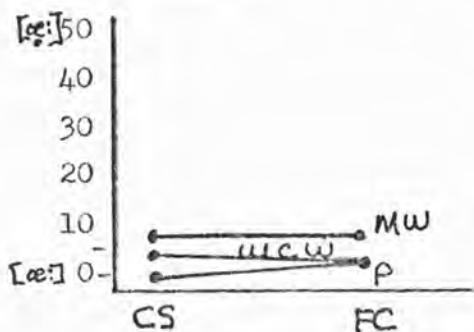

Fig. 13 % of responses to [æ:] by occupation and style.

However, all other stigmatized features have been selected, either in careful style or formal conversation, by these two occupational groups. What is interesting to note is the fact that selection of negative social markers is also made by higher-ranking occupational groups. A very low selection of these seems to be acceptable, whereas a high selection of any or all of these features would probably be felt as incorrect. The degree of selection of these stigmatized forms seems here to be the relevant feature in accounting for various patterns of behaviour.

The fact that workers are clearly differentiated from the two other occupational groups largely depends on the degree of selection of the stereotypes. In fact, selection of these is significantly higher by manual workers, in both contextual styles, although they are less differentiated from other groups in careful style. Their awareness of prestigious features is shown by the downward slope of the lines, as they move from a less formal to a more formal style of speech. In addition, the degree of style shifting is closely related to the higher or lower degree of usage they make of a feature in formal conversation. The more they select a feature in formal conversation, the more they avoid it in careful style, thereby displaying a great degree of style shifting. This is the case for [æ], [wɛ:], [we] and [e:]. On the other hand, a fairly low usage of a feature in a less formal speech situation leads to a less significant style shifting, in that the need to correct is not felt as strongly. In the case of [h], [x], [ɔ:], for example, a less important style shifting is to be observed. Use of these stereotypes remains at a fairly low level in both styles, compared with the one observed in the case of [æ], [wɛ:], [we], and [e:].

It has been said that high selection of any of the stereotypes studied is likely to be made by manual workers and less educated members of the community. Thus, high usage of forms which have risen to full social consciousness and to which a negative social value has been applied may be enough to enable prediction of the speaker's status. That is, if someone uses several forms which are rejected by educational institutions, mass media, etc., he is likely to be judged socially as being less educated and belonging to a lower social group.

This assumption depends largely on the subjective attitudes members of the society may have: not only their attitudes towards other members of the community, and how they view their own relationships with them, but also their attitudes towards language, i.e. if language is seen as a mirror of society.

There are good indications, as demonstrated by answers from informants (cf. chapter 3 and section 2.3.2), to justify the assumption that language is seen as the mirror of the society. People are aware that, through language, they can recognize others and be recognized themselves as having certain particular social characteristics.

Whatever idea one has of society, i.e. seeing present society as bad, good, to be changed or not, it remains true that members of a similar community are differentiated by their ideas, by factors such as occupation, level of education, etc., in industrialized societies such as Trois-Rivières. Language (the use of language and the subjective attitudes towards it) certainly provides a very good means of portraying such differences.

Linguistic features, such as linguistic stereotypes, clearly reflect the differences found within a society, as usage of these varies not only from speaker to speaker, but also from one group to another. Examples of the speech of individuals will be given here at some length in order to show that the behaviour of an individual towards linguistic features, such as stereotypes, reflects faithfully the tendencies of the group to which he belongs.

2.3.3.3 Examples of speech illustrating use of linguistic stereotypes

M.3.1.3 : Young male manual worker with 9 or fewer years of years of schooling.

[wɪ / sa deβã de plas/ kôm a lɔ / ʒ dwë bẽ äwɛ:r ʏn plas pʊ trävãje/ [ʃã:ʒ] ma manjɛ: də parle / pɪ tsɔ]

" Oui, ça dépend des places. Comme là, je voudrais bien avoir une place pour travailler. Je change ma manière de parler, puis tout ça".

M.3.2.3 : Young male manual worker with 9 or fewer years of schooling.

[päl tvhv də mɛ̃ / tvhv ge /.../ mwe ʒʒyʒ pɔ kɛlkœ a sa manje də parle / pʊr mwe/ se pɔ sɔ ki kɔ:t]

" Je parle toujours de même. Toujours gai... Moi, je(ne) juge pas quelqu'un à sa manière de parler. Pour moi, c'est pas ça qui compte".

M.3.9.3 : Older male manual worker with 9 or fewer years of schooling.

[ʒamɛ fiɔrɛŋ mezɔ / ʒamɛ / fæ kə / æ travajræ pʊr mwa /.../ arɛtɛ/ pɪt̪ ale vwɛ:ɔ kəs ki spɔsæ / tʃys kə se kə fi vɪ/

stæ pɔ̃ trə bo/ fæ kohvuzyü/ .../ kã h vwë këkõë ä ko•te
dɔ̃ rvt / ʒarɛ•t py /]

" Jamais 'j'aurais une maison. Jamais. (ça) fait que, elle travaillerait pour moi.(...) Arrêter, puis aller voir qu'est-ce qui se passait. Tout ce que j'ai vu, c'était pas très beau. (ça) fait que aujourd'hui, quand je vois quelqu'un à côté d'une route, j'arrête plus."

[twë ppa / te t õë vjɔ̃ hɔ̃ / tɕy kɔ̃prãdræë hamæ]

"Toi, papa, t'es un vieux-jeu. Tu comprendrais jamais".

M.3.4.3 : Older male manual worker with 9 or fewer years of schooling.

[ɔ̃n etæ syr ɣn notorvtɔ̃ / pi stæ la premjɛ• tãpɛ:t dʒivɛ• /
pur netwɔ̃je la rvt / ɔ̃ s mefjæ pɔ̃ / læ skrɛpɔ̃•r avæ ãbarke
õë pɔ̃ syl bö•r dla gravel / ɔ̃ nãʒys pɔ̃pe læ ko•te/ɔ̃ nɔ̃ pri•¹
{ã /.../ pærsɔ̃n ẽ•te blɛse/ dʒizæ se fini/ɔ̃ moɔ̃ : ɔ̃ tarive
ɣys dabvt sɣn sv}]

" On était sur une autoroute. Puis c'était la première tempête d'hiver. Pour nettoyer la route, on se méfiait pas, le scraper (i.e.grattoir) avait embarqué un peu sur le bord de la gravelle. On a juste poigné le côté. On a pris le champ. Personne a été blessé. (je) disais: c'est fini, on meurt. On (est) arrivé juste debout sur une souche".

[mwe hapɛlræ læ frãsãë dʒy këbɛk / parlɛ pɔ̃•tɔ̃ / ɣn patat
dã: bu}]

" Moi, j'appellerais le français du Québec "parler pâteux". Une patate dans (la) bouche".

F.3.2.3 : Young female manual worker with 9 or fewer years of schooling.

[nɔ̃ / kɔ̃m ɪstɪt a twɔ̃ rvjɛ:ɾ / ɔ̃ dʒi lava:ʒ / ã kãpã:p i
dʒi:z lava^v :ʒ / bujwɛ: / japɛl sɔ̃ õë kana^v :]

" Non. Comme ici à Trois-Rivières, on dit lavage. En campagne, ils disent "lavaouge". Bouilloire, ils appellent ça un "canard".

F.3.6.3 : Older female manual worker with 9 or fewer years of schooling.

[õ nã vwa./ mɛ•m dzɣ mõ:d ki võ {ɛ}e az dõne do:t manjɛ:/
põ• sã n apɛrswã t^{sy} sɣrt / mwe sa me t egal]

" On en voit, même du monde qui vont chercher à se donner d'autres manières. Puis on s'en aperçoit tout de suite. Moi, ça m'est égal".

[sõ vɔ dã õe bɣ•ro/ kək {o:z kõm sɔ / i võ puvwɛ: nɣ
zɣzɛ/ mwe zma d^{zi} sõ]

" Si on va dans un bureau, quelque chose comme ça, ils vont pouvoir nous juger. Moi, je me dis ça".

F.3.8.3 : Older female manual worker with 9 or fewer years of schooling.

[ɛtarive l mɔmã dõne/ kə mwe / zɛ dmãde/ zɛ d^{zi} ã tɣ kɔ /
me zari:v ã kanado / zɣvɔd mã•de a me zã•s/ də kɛl lã:ɛ̃ kõ
pa•l/ pas^t kə {pã:s kə se mwe kɣ_l fae defo dã tv / paç kə
le zo:t sə kõpranæ tut / pi ø zo:t mə kõpranæ pɔ]

" Est arrivé le moment donné, que moi, j'ai demandé, j'ai dit: en tout cas, mais (quand) j'arrive en Canada, je vais demander à mes gens, de quelle langue qu'on parle. Parce que c'est moi qui fait défaut dans tout. Parce que les autres se comprenaient tout, puis eux autres me comprenaient pas".

[zɛ dmãde ɣn sɔrt dafɛ^e: / hɛ d^{zi} / mã:h pɔda tsɔ/ mwe /
tvhv la go ɛtæ lɔ / mə rgɔrdæ/ setæ põl mãzɛ kə zavæ
dezire davwɛ:]

" J'ai demandé une sorte d'affaire. J'ai dit: (je) mange pas de ça, moi. Toujours, le gars était là, (il) me regardait; c'était pas le manger que j'avais désiré d'avoir".

The examples given up to now illustrate how some people use archaic phonetic features. Most of these features are present in the speech of these informants. What has to be remembered is that although less educated informants very

often select one or more stigmatized features, their usage of such forms is always in co-variation with the more prestigious features, such as [ʒ] instead of [h], [wa] instead of [wɛ,we], [ɛ] instead of [æ], etc. Both varieties, i.e. standard French ones and archaic ones, are part of their speech. However, they select archaic ones sufficiently often to differentiate them from more educated informants. Speech samples of more educated informants will illustrate the differences in selection of these features.

M.1.2.1 : Young male professional with 13 or more years of education.

[javɛ yn otomobil kʲatãdɛ ä œ n arɛ obigatwã / o kwɛ dʲn
 ry / pʲi a / jayɛ bokud glas / salʲi kʲi sã vne ã narʲe:v /
 a pb frɛ·ne atã / pi/ je rãtre dʲiãk dadã]

"(il) y avait une automobile qui attendait à un arrêt obligatoire, au coin d'une rue. Puis, (il) y avait beaucoup de glace. Celui qui s'en venait en arrière a pas freiné à temps, puis (il) est rentré direct dedans".

M.1.8.1 : Older male professional with 13 or more years of education.

[le zɛksprɛ sjõ kõ na / la vokabulɛ kõ na / (pã:s kõ na pa
 a sa la rprõ) e /.../ evidamã i fo admet ka o kõtak avɛk
 lãglɛ /.../ laksã ne pb la mɛ·m ka (e z ø / õ nɛ sista pb /
 õ prõnõ·s pa a la fasõ kʲil fõ ã frã:s]

"Les expressions qu'on a, le vocabulaire qu'on a, je pense qu'on a pas à se le reprocher. Évidemment, il faut admettre qu'au contact avec l'anglais, l'accent n'est pas le même que chez eux. On n'insiste pas, on prononce pas à la façon qu'ils font en France".

M.2.2.1 : Young male white collar worker with 13 or more years of education.

[sõ prã legzãp dɛ sɔ kʲi puã damœne syr la ko·to/ pi sɔ
 kʲi damœ:v sy la ry sɛ pɔl / la fasõ d parle e dʲiferãt
 œ pɔ / i võ parle pʲys kõm / sã frɛ·r atãsjõ tro tro /

mrljə/ edʒykasjɔ̃]

" Si on prend l'exemple de ceux qui pourraient demeurer sur le côteau, puis ceux qui demeurent sur la rue St-Paul, la façon de parler est différente un peu. Ils vont parler plus comme, sans faire attention trop trop. Milieu, education.

M.2.4.2 : Young male white collar worker with between 10 and 12 years of schooling.

[nɔ̃ / mjə parle lɔ̃ / mwã {trɔ̃ se fɔ̃rse ẽ pə tro/ɔ̃ pə
ãplwãje le tɛ̃rm ʒyst / dakvʳ: / da dlɔ̃ a ale prã:d nẽpɔ̃rte
ki/ pɔ̃i i dʒr / tɔ̃ã tʳy vɔ̃ bjẽ parle / la gɔ̃ ki trava.j dã
zy nyzin / tœ pakæ d gɔ̃ ɔ̃tu: dalɔ̃i/ se pɔ̃ dʒy tu l mɛ̃m
parle kã kã tʳy vɔ̃ dã œ byro]

"Non, mieux parler, là, moi je trouve c'est forcé un peu trop. On peut employer les termes justes, d'accord. De là à aller prendre n'importe qui, puis lui dire: toi, tu vas bien parler! Le gars qui travaille dans une usine, t'as un paquet de gars autour de lui. C'est pas du tout le même parler que quand tu vas dans un bureau!"

F.1.6.1 : Young female professional with 13 or more years of education.

[ʃʀe ptɛ̃t pɔ̃ pur kə sa swa la fɔ̃rm də lã:g ki swã ãsepe
dã le z ekɔ̃l par egzã:pə / me dœ no:t kõte / ʒmã dʒi skje
tẽpɔ̃rtã / se ptɛ̃t kə le ʒã:s sã:t bjẽ]

" Je serais peut-être pas pour que ce soit la forme de langue qui soit enseignée dans les écoles, par exemple. Mais, d'un autre côté, je me dis: ce qui est important, c'est peut-être que les gens se sentent bien".

F.2.5.2 : Older female white collar worker with between 10 and 12 years of education.

[me otrãfwa le ʒã / ʒmã rapel ply ʒœn / le ʒã ki parle bjẽ
avɛ lɛ̃r snɔ̃b / avɛ lɛ̃r œ ptʳi pə a pa:r / me ɔ̃ʒvɔ̃zɔ̃r ʒan
pã:s pɔ̃ / ... / sa dʒimɛ̃ny sœ]

" Mais autrefois, les gens, je me rappelle plus jeune, les gens qui parlaient bien avaient l'air snob, avaient l'air un petit peu à part. Mais aujourd'hui, je ne pense pas...; ça diminue ça!"

As the speech samples illustrate, individual speakers generally follow the pattern characteristic of the group to which they belong, i.e. the statistical tendencies of each individual are reflected in the statistical tendencies of the group with which he associates himself. At least in the case of linguistic stereotypes, the grouping of speakers according to their social characteristics appears to be justifiable.

In fact, all speakers who made a high selection of one or more linguistic stereotypes were the ones who spent fewer years at school and who were unemployed or unskilled workers. The speakers who selected these forms very rarely all had at least 10 years of schooling and were mostly skilled workers, white collar workers or professionals.

The level of education is probably the most significant factor in accounting for different uses of such linguistic markers. The less contact a speaker has had with educational institutions, the more likely he is to conserve these forms in his speech.

However, despite having been in contact with educational institutions over a shorter period of time, such a speaker is nevertheless aware of the existence of other forms. He will more often use the forms associated with "good" speech when the situation requires it, as illustrated by careful style.

Linguistic stereotypes are one of the many facets characterizing what is referred to as "joyal" in Québec. This form of language could be compared with "Cockney" in London or "Argot" in Paris. A brief commentary on "joyal" will be given here, in that it is closely related to usage of linguistic stereotypes. This description may also further enlighten the social significance which language carries.

2.3.4 "Joual": a speech variety of Québec French

. The term "joual" is used to designate the popular speech in Québec. This form of language has two main sources: the first source is the speech inherited directly from French settlers in the 17th century. The mere use of the term "joual" illustrates these origins, in that it reflects the popular pronunciation of that time for the word cheval. This form of language, characterized by extensive use of archaic pronunciation features, such as icitte (ici), moé, toé (moi,toi), etc., was, until recently, the language mainly used by peasants. However, with the process of industrialization, there has been a considerable population shift from the country to the towns, and this form of language has been brought more widely into the cities.

The second source is related to the influence of English on French since 1759. For a long period, this influence of English on French was only superficial. With industrialization, however, the working class moved into towns, and especially into Montréal, where, because of daily contact with the English language and an obligation to use it more or less extensively for work, a form of speech developed which was full of English terms. This form of speech is what is now called "joual", i.e. a language characterized by usage of archaic phonetic features and influenced by English, not only in the lexical field, but also in the syntactic and phonetic ones.

Many of these anglicisms have been perfectly assimilated not only in the speech of those who speak "joual", but also in the speech of all Quebecers. Examples of such anglicisms are words like appointment (rendez-vous),

intermission (entr'acte), etc.

If "joual" is in a process of becoming more and more anglicized, it still remains closer to French than to English. Its basic structures are French and, even though its syntax is influenced by English, it retains basically the same syntax as Standard French. "Joual" is not a language in itself but rather a level of language.

This level of language can be compared with another one, namely Québec French. No precise markers exist between these two levels of language, it is only a question of degree which differentiates them both. For example, Québec French would rarely have forms such as moé, toé, etc., and the use of English terms is more controlled in Québec French than in "joual". The term "joual" has moreover a negative value attached to it, in that it is considered by the majority of Quebecers as bad speech, i.e. a form of language free from rules, spoken in some circumstances by a part of the population.

What is interesting to note is that most people who are likely to use "joual" do not think or say of themselves that they speak "joual", but that they speak French. "Joual" is a term used rather by the bourgeoisie to qualify a form of language which it does not use, a form which it holds in some contempt.

However, who speaks "joual" ? First, it should be said that this variety is present everywhere in Québec, in that all Quebecers understand it and use it occasionally. It is however not present to the same degree in the language of every speaker. Usage of "joual" or Québec French is closely related to social factors. It is certain, as shown by the

results concerning use of archaic features by Trifluvians, that "joual" is more widely used by workers for example, than by professionals. From this point of view, language, in Trois-Rivières as elsewhere, reflects the social differences present in a society.

It would be false to think, however, that manual workers or less educated informants use "joual" exclusively. As is also shown by the results, these speakers use also Québec French, but use of both varieties by them is more frequently in co-variation than in the speech of more educated and middle-class members of the community.

A number of external factors, such as educational institutions and mass media, have contributed recently to a diminution in the use of "joual". Indeed, a more standard French is taught or used by these institutions (1), and it has certainly had an influence on the language. Not only have they had an influence on the language, but in addition, they are themselves a reflection of what is considered by the population as the best means for communication. Québec French is the variety used, since "joual" is rejected by these institutions. Newspapers, for example, need to establish contact with their readers. The fact that they use Québec French rather than "joual" to obtain this contact implies clearly that "joual" is not nowadays the important vehicle of communication.

Of course, it remains true that "joual" is still spoken in Québec, mainly by less educated speakers, but both forms of speech are used by them, as seen in the above study of archaic phonetic features. It is only that "joual" appears

(1) The word "institution" has been chosen to represent both educational institutions and mass media, since both are considered as transmitter and creator of values.

more frequently in their speech, than in the speech of middle-class members of the community.

"Joual" is certainly a form of speech which is regressing in Québec, especially when anglicisms are considered. There is a strong movement to "frenchify" terms in the language, as the danger of the American and English-Canadian cultures overcoming the French culture is felt more and more acutely. With this view in mind, considerable efforts have been made recently to use French words in sports, for example, where before English terms, such as goaler, puck, pitcher, etc., were used. This attempt to use French words is seen in one answer to the questionnaire. People were asked the question: On allume une cigarette avec une allumette ou un...? The answer being briquet. Some of the less educated informants in the sample answered spontaneously by the word lighter, one of the English loan words widely used in "joual". What is interesting, is that, as soon as they gave the answer, they immediately corrected themselves by saying: "Non. Briquet".

The need to change back to French many lexical items which were replaced by English loan words is felt acutely by these speakers, as proved by their spontaneous correction of the word lighter.

They also begin to use less archaic forms, as has been seen for [h], [x], [œ:], where a linguistic change is in progress, and for all other forms when careful style is considered.

Whatever the status of "joual" or Québec French, however, it is clear that language in Québec is passing through a period of relative instability, all of which is due to subjective attitudes towards language.

Very different tendencies are to be seen in this regard. Some purists try to eliminate from Québec French all features which do not conform to official usage in France. They go as far as to eliminate words like noirceur (obscurité), magasinage (shopping), poudrerie (tempête de neige), etc., i.e. all Québec French innovations which reflect the life, personality and reality of Quebecers. They try to approach the Parisian accent as closely as possible.

On the other hand, the majority of Quebecers try to eliminate inappropriate anglicisms and to correct their pronunciation by eliminating archaic features, as has been illustrated by the patterns of behaviour of most Trifluvians interviewed. They also try to discover their own norm, i.e. a Québec French norm (cf. chapter 3).

A final tendency could be called "joualisante". This tendency is marked by the emergence of extensive usage of "joual" by some playwrights, who view "joual" as the best means of expressing a Québec reality. In addition, some young students are seen to be returning to "joual" either as a reaction against the establishment, or in order to identify themselves as truly Quebecers, and not as French, Canadian or whatever else.

This conscious usage of "joual" made by some Quebecers is not surprising. Québec French is indeed considered by some to be inferior to the French used in France, especially that of Paris. A strong feeling of inferiority is felt when language comes into play. This is true of many of the informants interviewed. Although they all rejected the idea of using a Parisian accent, many of them felt the need to correct Québec French, i.e. to approach a more international

French. This last point will be more thoroughly discussed in a special section on attitudes towards language (cf. chapter 3).

For the time being, however, it is interesting to note this reaction, since it reflects a strong insecurity towards one's own culture. Some Quebecers react strongly to such attitudes, by extensive use of "joual". These moreover react against a purism, which tries to eliminate all characteristics of Québec French.

All these different attitudes towards language show that the problem is far from being resolved. Whatever reactions towards language there may be, however, it is true that, in general, "joual" is nowadays a form of speech characteristic of the less educated members of the community. It may also be a characteristic of some more educated speakers, mostly intellectuals, who are searching for a proper identity.

Québec French remains, however, the main form of language used for communication. The true character of this language remains to be determined, i.e. a norm proper to Québec French is still to be found, and official recognition of this "accent" must be achieved, if insecurity towards one's own language is to disappear (1).

(1) For discussions about attitudes of Quebecers towards Québec French, see: E.Brent, (1971), pp.113-115 ; W.E. Lambert, (1972).

2.3.5 Conclusions

From this description of "joual" and Québec French, and also from the patterns of behaviour of Trifluvians towards either form of language, it appears clear that the use of archaic phonetic features, related to "joual", is closely linked with social factors. The use of stigmatized features is characteristic of less educated members of the community, and its use is viewed in general as something to be rejected from everyday speech.

Since contact with educational institutions is growing, the average attendance at school being higher, and since the mass media, especially television, is more and more important in the lives of members of the community, the use of archaic forms is likely to diminish considerably, such forms not being used by these institutions.

Attitudes towards language, however, may have an effect upon the time it will take for these forms to regress in the speech of individuals, as has been seen in the case of the young, female manual worker.

Since the use of anglicisms is seen more and more as a threat to French culture in Québec, these are probably the features most likely to disappear in the speech of Québécois.

On the other hand, usage of archaic phonetic features do not represent such a threat. On the contrary, they may be seen as a means of identification with a Québec culture or a specific social group. Therefore, if considered as

such, there may also be an increase in their usage (cf. young, less educated informants in their behaviour towards [wɛ:] and [we] for example).

It is therefore difficult to predict what will happen to linguistic features, which have risen to full social consciousness and which carry so many different subjective attitudes.

For the present purpose, however, and also taking into account the limits of the interview situation, the following conclusions may be drawn as regards the use of linguistic stereotypes by the Trifluvians interviewed.

1- High selection of all linguistic stereotypes studied is closely related to the level of education and occupation of the speaker, i.e. manual workers of 9 or fewer years of education are expected to select highly stigmatized features.

Comparing these latter together, the following conclusions may be drawn:

a) linguistic change in progress:

High selection of linguistic stereotypes undergoing linguistic change is moreover a function of sex and age, i.e.

$$(1) \left\{ \begin{array}{l} -v \text{ (z)} \text{ (f)} v- \\ \#(z) \text{ (f)} - \\ -(z) \text{ (f)} \# \end{array} \right\} \longrightarrow \langle [h, x] \rangle$$

$$(2) \left\{ -(œ) + r\# \right\} \xrightarrow{f \text{ (sex, age)}} \langle [œ:] \rangle$$

In these cases, older men are likely to select these variants more often than young men, and men in general are expected to use these varieties more often than women.

b) No linguistic change in progress:

High selection of linguistic stereotypes not undergoing linguistic change are likely to be selected at about the same level by all sub-groups of less educated speakers. This is the case for [æ] and [wɛ:].

However, even in a static linguistic situation, older members may select these features less often than younger members, because of a longer contact with more "prestige" forms. This may be observed for [wɛ:] in careful style, and for [we] and [e:] in formal conversation.

2- All speakers are aware of the social significance attached to usage of archaic linguistic features.

More educated speakers have almost completely rejected usage of any of these forms, at least in the styles of speech elicited in the interview.

Less educated informants, although making considerable use of some features in formal conversation, show their awareness of speech forms considered to be more correct, by reducing their use considerably in a more careful style of speech.

3- There is also here the question of degree which is very important in differentiating speakers. Although most of the

stigmatized features are absent from the speech of more educated members of this community, it may be postulated that there are domains of interaction where selection of these could be made at a higher level of occurrence by these speakers.

In fact, the selection of stigmatized features is probably dependent to a marked degree on the situation in which a speaker finds himself. The more formal the situation, either because of the type of relationship between the interlocutors involved, or because of external factors, such as the environment in which the interaction takes place, the topic, etc., the less likely these features are to be selected by any member of the community.

On the other hand, a higher selection of linguistic stereotypes may be expected by less educated speakers and manual workers in any speech situation.

Linguistic features which have risen to full social consciousness and to which a negative social value is attached constitute markers worthy of consideration. They offer in fact the possibility of examining subjective attitudes of speakers towards such forms and of comparing their attitudes with their linguistic behaviour. As seen by the discussion and results above, linguistic stereotypes are involved in different social processes, and they are certainly one of the most interesting linguistic features enabling observation of the society in which they are used, and also reflecting the social tensions and differences which are present between various members of a society. Identification with any social group can best be viewed through the use people make of language.

2.4 The study of long vocalic segments, i.e. /ɛ, a, œ, ɔ/

2.4.1 Vowel length

Differences of quantity as well as of quality are often significant in distinguishing words. For example, Québec French maître and mettre are distinguished quantitatively, the former having a long vocalic element, the latter a short one.

In addition, variations of length may be related to different phonetic (qualitative) realizations of the same phoneme. For example, pâte may be realized as [pa:t], [pa:t̃], [pa^v:t] , [pɔ:t] , etc. In this case, the length of the vocalic segment has an effect on the quality of the phoneme, to which four different phonetic realizations may be given. It is this type of investigation which will be considered in this study, namely the effect of the length feature on the phonetic realization of a given phoneme. The quantity of a sound will therefore be of interest when implying different surface realizations (such comments on quantity being based on auditory judgments).

2.4.2 Québec French long vowels

Vowel length in Québec French is either phonetic or lexical.

When phonetic, vowel length is predictable in Québec French. /a/ and half-open vowels /ɛ, œ, ɔ/, i.e. vowels investigated in this study, are predictably long when followed by one of the lengthening consonants /v(r), r, z, ʒ/ before word boundary. The glide /j/ is traditionally included in this group, as being a lengthening consonant. However, studies like those of Gendron tend to demonstrate that /j/ does not have as much a lengthening effect on vowels as /v(r), r, z, ʒ/. In fact, Gendron compared words like soude, souille, soupe, fille, fil, fiche, in which /u/ and /i/ do not become longer before /j/ and moreover are articulated with the more open and less spread variety characteristic of Québec French, namely [v] and [ɪ]. In these cases, /j/ has exactly the same phonetic effect as all other word final consonants, excluding /v(r), r, z, ʒ/, in that /i, u, y/ are realized as more open and with less extreme lip action, i.e. [ɪ, v, ʏ] (1). Gendron adds that /ɛ/ is slightly open and long before /j/, as in soleil, whereas this vowel is realized as very open and long in words like collège, père, etc. In the case of /a/, a front open unrounded /a/ is used in words like bail, in which /j/ has no lengthening effect on the vowel, whereas in words like baille, a long back /a/ is used. For this latter case, Gendron states that "cette durée provient de "l'affaiblissement de ɥ palatal en y et de l'amuissement de l'e final" " (2).

Since /j/ has been proved in many studies not to have as much lengthening effect upon vowels as /v(r), r, z, ʒ/, it is now excluded by all Québec French phoneticians from this group. Moreover, the vowels investigated in this study can undergo a process of diphthongization and of opening or

(1) J.D.Gendron, (1966), pp.140-41

(2) Id. p.141, in which Gendron quotes G.Straka; the symbols ɥ and y stand for ʎ and j in the IPA notation.

closing when in a lengthening consonantal context. No such phonetic realizations have been found when the vowels were followed by the glide /j/, with the exception of /a/ in words like baille, etc. Thus, the glide /j/ will not be considered as one of the lengthening consonants, and only /v(r), r, z, ʒ/ will be concerned in the following vowel lengthening rule:

$$v \longrightarrow [+long] \quad / \quad - \quad \left\{ \begin{array}{l} v(r) \\ r \\ z \\ ʒ \end{array} \right\} \#$$

There may be some exceptions to this rule in that these vowels are often shortened before /v/ and /vr/. For example, /œ/ in veuve often appeared to be shorter than in beurre.

Lexically determined vowel length, i.e. vowel length operating phonologically, is however unpredictable. Open back unrounded /a/ and half-open unrounded front /ɛ/ are the only lexically determined long vowels. These two vocalic segments may be long before any word final consonantism.

The areas where back /a/ is used instead of front /a/ were described in section 2.2. In this section, studies on this vocalic segment were mentioned, in which length was said to play an important role in determining the quality of the vowel. The environments favouring the use of a long segment were said to be also the ones favouring the use of an open back unrounded phoneme. The use of a long segment is not only phonetically determined but also lexically determined.

As was stated in section 2.2, a long [a:] is to be expected in words like accable, diable, cable, but a short [a] in aimable, agréable, etc.

The length of the phoneme /ɛ/ is also lexically determined. With the spelling -ê, -ef, -af, /ɛ/ will always be long, independent of the following consonant. In these cases, words like mettre and maître are distinguished by means of the length feature.

When written -ai, -e+sse, however, the length of the vocalic segment is likewise lexically determined. In the environment -ai +sse, words like caisse, baisse, graisse will have a long allophone, whereas in laisse, etc., a short one will occur. In the environments -ai + l,g,d,b,n,m,gn, a long /ɛ/ will occur in haine, vinaigre, but a short one in aille, laine, baigne, etc. Finally, when written -e + sse, the vocalic segment will usually be long in cesse, confesse, etc., but short in tesse, messe, etc. The length of /a/ and /ɛ/ is therefore lexically as well as phonetically determined, but only when length is phonetically determined will it also be predictable.

Québec French long vowels are manifested by a marked prolongation of the vowel. The length feature of any vowel may be emphasized by the fact that vowel length may also imply a segmentation of the vocalic element into a lower nucleus and a closing segment in the same vocalic area. This diphthongization affects all long vocalic segments, although not all are liable to be diphthongized to the same degree. Another effect of length on the quality of the vowel is the opening of the half-open segments and the closing of the open back unrounded phoneme. Gendron (1966) gives good evidence of this feature in the vowel /ɛ/, which is very open in

words like fève, less open in sève, and the least open in fait (1). Brent also notes that, especially before /r/, [a:] frequently replaces long /ɔ/, this last segment being therefore realized as very open, and concomitantly, /a/ is backed when lengthened (2). Jackson (3) refers also to the opening of the segments /œ/ and /ɔ/ and to their diphthongization.

The feature [+long] has therefore various phonetic effects on the quality of the vowels:

- 1- /ɛ, a, œ, ɔ / , in the environments favouring the feature [+long] , may be realized with near cardinal vowel values and are usually very long;
- 2- All four syllabic segments may be liable to become diphthongized by means of opening the initial segment and moving to a closed element in the same vocalic area;
- 3- The half-open segments may be more open and accompanied by less lip action so as to give articulations described as:
/ɛ:/ → [ɛ̃:] ; /œ:/ → [œ̃:] ; /ɔ:/ → [ɔ̃:] ;
- 4- The open back unrounded vowel may be backed and rounded and be replaced by [ɔ̃:] .

The following table illustrates the phonetic effects of the feature [+long] on the vowels under study. However, it should also be noted that in a syntactically nonprominent position, lexically or phonetically determined vowel length may or may not be realized. An example of recorded speech will illustrate this point:

(1) J.D.Gendron, (1966), pp.69 and 197 (fig.28)
 (2) E.Brent, (1971), p.48
 (3) D.M.Jackson, (1968), p.71

Phonemes	Short allophones	Simple long allophones	Simple long open allophones	Diphthongal long allophones
/ɛ/	[ɛ] <u>mettre</u>	[ɛ:] <u>maître</u>	[ɛ:] <u>maître</u>	[ɛ ^r :] <u>maître</u>
/a, a/	[a] <u>malle</u>	[a:] <u>mâle</u>	[ɔ:] <u>mâle</u>	[a ^v :] <u>mâle</u>
/œ/	[œ] <u>peuple</u>	[œ:] <u>peur</u>	[ʌ:] <u>peur</u>	[œ ^y :] <u>peur</u>
/ɔ/	[ɔ] <u>forte</u>	[ɔ:] <u>fort</u>	[ɔ:] <u>fort</u>	[ɔ ^v :] <u>fort</u>

Table 14: Phonetic effects of the length feature on the realization of /ɛ, a, œ, ɔ/.

Inf.34 [i v^o saksprime patɛ·t ʔ ʒwal]
 "Il va s'exprimer peut-être en joual".

[bɛ̃ / pøtɛ^r:t]
 "Bien, peut-être".

In the first case, the length of phonetically determined long /ɛ/ is shortened when in a nonprominent position, whereas in the second example, /ɛ/, in the same environment but in a syntactically prominent position, is fully realized as long and moreover diphthongized. As seen in this example, the same speaker gives two different surface realizations to the phoneme, according to its place in the utterance.

In the first part of the questionnaire, words were said in isolation, thus all being in a syllabic prominent position. The following lexical items were used to study the

phenomenon of diphthongization of long vowels in careful style, as well as that of the opening of half-open segments and closing of open back unrounded /a/.

/a/	/ɛ/	/œ/	/ɔ/
baille	tête	veuve	gorge
taille	fête	oeuvres	horloge
tasse	fenêtre	fleuve	corps
pâte	maître	heure	castor
pâle	vêlé	beurre	fort
as	graisse	couleur	mort
basse	carême	fleur	dort
âne	scène	peur	nord
gagne	chêne	soeur	bord
réclame	seize	humeur	mords
condamne	chaise	coeur	
âme	soustraire	menteur	
soir	première	cultivateur	
mâchoire	dernière	balayeur	
bouilloire	hiver	chanteur	
abreuvoir	hier	largeur	
mouchoir	verre		
noir	cuillère		
fromage	neige		
lavage	mère		
garage	père		
repassage	frère		
âge	cher		
pages	bière		
nuage	rêve		
tard			
gare			

In connected speech, either in a reading passage or in conversation, long vowels occurred in both nonprominent and prominent positions. Although diphthongization and opening or closing of the vowels affected long vocalic elements in nonprominent positions, the degree to which these phenomena occurred was far more important when the long vowels were found in a syntactically prominent position, as the example given above illustrates.

Thus, the environments in which diphthongization and opening or closing of the phonemes studied will be favoured are:

- 1- when the vocalic elements are followed by /r, v(r), z, ʒ/ before word boundary;
- 2- when lexically determined long /a/ and /ɛ/ occur;
- 3- when the long vocalic segments are in a syntactically prominent position.

2.4.3 Diphthongization: general outline

Table 15 and diagram 14 give an overall view of the phenomenon of diphthongization for all informants in the three contextual styles.

As /ɛ/, being [ɛ̄long] when written ei, ai, eɪ, aɪ, ê, ê̄, and when followed by any of the lengthening consonants, except /r/, was diphthongized significantly more often than when followed by /r/, study of the phenomenon of the diphthongization of this phoneme had to be considered separately in both environments. The same distinction was made for /a/,

but no discrepancy between both environments appeared to be significant. Diphthongization of /a/ was therefore studied as a whole, without any distinction of phonetic environments.

/œ/ and /ɔ/, being [+long] only when followed by one of the lengthening consonants, i.e. /v(r),r,z,ʒ/, were diphthongized in the examples obtained in the interviews only when followed by /r/. In the other environments, these two half-open vowels were generally realized as slightly more open and with less lip action than the cardinal vowels. Since diphthongization of these two vocalic segments occurred only before /r/ in the speech recorded, /r/ was the only environment retained in the study of diphthongization of /œ/ and /ɔ/.

Environments	Styles		
	RS	CS	FC
/ɛ/ → [+long] / - {lexically determined spelling: ai, ei, è, af, } # ef, ê /v(r),z,ʒ/	35%	48%	40%
/ɛ/ → [+long] / - /r/ #	6%	17%	20%
/a/ → [+long] / - {lexically determined /r, v(r), z, ʒ/ } #	10%	21%	16%
/œ/ → [+long] / - /r/ #	9%	17%	16%
/ɔ/ → [+long] / - /r/ #	---	18%	4%

Table 15: Averaged percentage of diphthongization for all informants by environment and style.

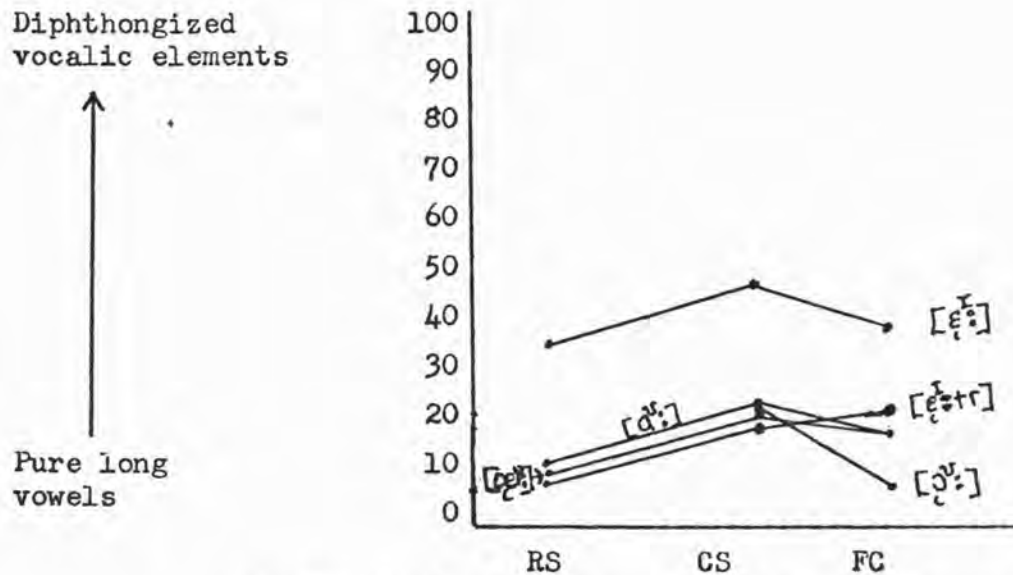

Fig.14 : % of diphthongization of each vowel by style, for all informants.

The phenomenon of diphthongization is examined in conditions ideally favouring its appearance, i.e. lengthening consonantal context and vowels in syllabic prominent position. It is immediately apparent that realization of a diphthongized element does not affect all long vocalic segments to the same degree.

From all long vowels studied, the half-open front unrounded vowel is the most diphthongized. Moreover, it is diphthongized the most often when long historically, whereas its percentage of diphthongization when followed by /r/ nears the percentages of diphthongization of all other vocalic elements.

Jackson, in his study of the vocalic system of Gravelbourg, arrives at exactly the same conclusions. As

he states: "La diphtongaison du E... résiste le plus à l'influence "corrective" du français standard, surtout dans le cas des graphies: ai, ei, af, ef, è, ê, en syllable accentuée fermée " (1). A high rate of diphthongization in these environments was found amongst his informants.

Juneau also refers to the diphthongization of /ɛ / in his historical study of Québec French phonology. The ALF maps 129 bêtes, 169 braise, 1300 tête, demonstrate that this phenomenon was found in the West part of Northern France, from Normandie to the Charentes, but being widespread mainly in Poitou.

Archives give indications that diphthongization of /ɛ / has existed in Québec French from the 18th century. e.g. faire: "Je donne plaien pouvoier de faier" Archives de la Province de Québec, Petites Collections, Rodrigueux J. 19 mai 1772, Québec (2).

/ɛ /, in the environments favouring the length feature, except /r/, is the most diphthongized vowel. It is stratified from the other vocalic elements to the same degree in all contextual styles.

The other vowels, i.e. /ɛ,œ,ɔ / + /r/, and /a /, long historically and + /r/, are diphthongized at about the same level in all styles. No phonetic conditioning in the nature of the vowel, as [[±] round] features, etc., seems to affect realization of the diphthongization in these environments. Only /ɔ / in formal conversation is significantly less diphthongized than the other vocalic segments.

(1) D.M.Jackson,(1968), p.72

(2) M.Juneau,(1972), p.84

What is also interesting to note is that in almost all cases, the phenomenon of diphthongization is not involved to an important degree in a process of stylistic variation. Usually, in careful style and formal conversation, the percentage of diphthongization is realized to a similar degree. Only in reading style is a decrease in the phenomenon to be regularly observed. However, the degree of style shifting is far less important than the one found in the study of variable (a)-1 and that of archaic phonetic features.

Moreover, in these studies, it was rather the opposition of reading and careful styles v. formal conversation which accounted for interesting differences. In the case of diphthongization, the same does not apply. If more diphthongizations are to be found, it is rather in the careful style in which words were pronounced in isolation that they might occur.

On the other hand, most vowels are diphthongized at about the same level in careful style and formal conversation. There is no significant shifting from one style to the other, except for the half-open back rounded phoneme /ɔ̞/.

It seems as though diphthongization of long vowels is not accidental, i.e. a phenomenon which would occur sporadically, but rather a general mode of articulation which is realized regularly and proportionally according to contextual conditions.

Gendron mentions this phenomenon of diphthongization and attributes it to a vowel which has become "too long" (1). As the vowel is "too long", weakening of the muscular contraction takes place, therefore producing diminution in the

(1) J.D.Gendron,(1966), p.61 and p.95

opening of the vowel in the final part of the vocalic holding. This applies to all long vocalic segments.

Diphthongization, not existing in Standard French, would be one of the features distinguishing Québec French from Standard French. According to Ferguson's model (1), diphthongization in a diglossic situation would occur in the low variety of language, rather than in the high variety of language, low and high varieties being defined by Ferguson as:

" For convenience of reference the superposed variety in diglossias will be called the H ("high") variety or simply H, and the regional dialects will be called L ("low") varieties or, collectively, simply L" (2).

The results obtained in this study demonstrate that a situation of "diglossia" is not involved. Reading style and careful style are the contexts in which the high variety is expected, rather than the low, because of attention being specially focused on pronunciation. In these styles, especially in careful style, diphthongization is realized at a high level, therefore being an element of the high variety, as well as of the low.

It seems as though the phenomenon of diphthongization is not so involved in differentiating styles of speech, and therefore has not risen to social consciousness, as much as variable (a)-1 and archaic phonetic features. It is a phenomenon realized by all speakers in a regular manner, and may be due to what Gendron calls a vowel which has become "too long".

(1) C.A.Ferguson, (1959).
 (2) Id., p.234

Even though diphthongization in this general table seems a regular linguistic structure, i.e. affecting all long vocalic elements to about the same degree in all styles, it is nevertheless involved in social stratification, as the study of sociological parameters will demonstrate.

2.4.3.1 Differentiation by age

Statistical tests do not provide significant discrepancies between age groups, since diphthongization of all phonemes always occurs at a low level. The differences between age groups never go beyond a proportional difference of the order .250 . Nevertheless, young informants diphthongize all vocalic segments less often than their older counterparts in all styles. Reduction in the incidence of diphthongization by young informants probably gives a good indication of a linguistic change in progress.

As seen in table 15, long / ϵ /, historically and lexically determined, is the most diphthongized of all long vocalic elements. This vowel will first be considered in order to examine which tendencies each age group seems to follow.

Informants aged 45 and over diphthongize / ϵ / almost twice as much as those aged between 15-24 in all styles. The middle-age group falls in between these two latter except for formal conversation, where their use of a diphthongized element is at exactly the same level of occurrence as that of their older counterparts.

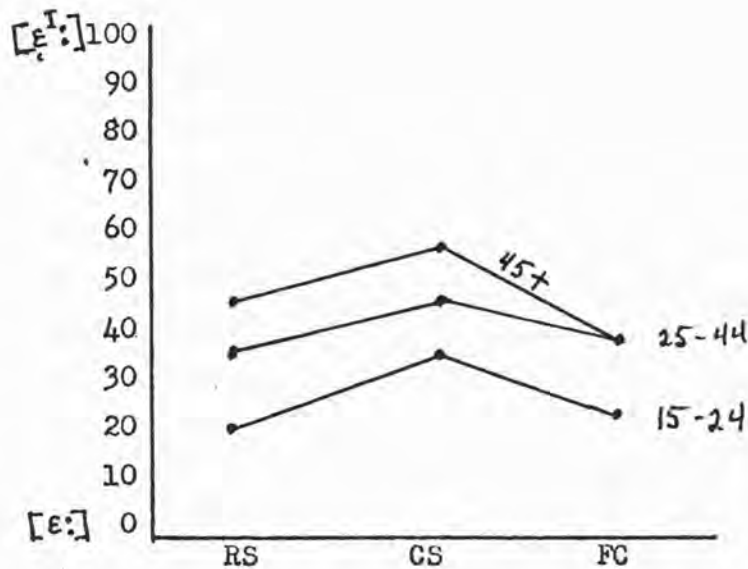

Fig.15: % of diphthongization of /ε/ by age and style.

Diphthongization of long /ε/ offers a type of structure which may be qualified as regular. By "regular structure" is meant that all groups are differentiated in all styles to the same degree, when proportional differences in the realization of a diphthongized element are considered. Another factor is that incidence of diphthongization can be predicted as the highest in careful style, where words were spoken in isolation, whereas it will be predictably realized to a lower or about equal degree in reading style and formal conversation, i.e. when words containing long /ε/ occurred in connected speech. The same predictions can be made for all age groups. All of them indeed seem to follow the same tendency, by diphthongizing the most often in careful style, and the least often in connected speech.

Style shifting is not very important as far as awareness of a linguistic feature is concerned. The opposition of formal v. less formal situations is not likely to be the

most relevant feature in accounting for differences between various speech styles. Diphthongization of /ɛ/ does not seem to have risen to social awareness, since all groups diphthongized more often in a formal speech situation (careful style), and at an equal proportion in two opposite speech situations, i.e. reading style and formal conversation. The relevant feature is rather syntactic, i.e. words spoken in isolation v. words pronounced in connected speech, this distinction applying to all age groups.

Thus, this variable has no social significance, i.e. is not so much involved in stylistic variation, but shows a uniform change from one age level to the other. Observation of the behaviour of different age groups towards diphthongization of /ɛ/ shows that, the younger the informants are, the less often diphthongization will be realized and vice versa.

The other vocalic elements must now be examined in order to discover whether the tendencies of age groups are the same when diphthongization of other vocalic elements is considered.

Age	/ɛ/ +r			/a/			/œ/ +r			/ɔ/ +r		
	RS	CS	FC	RS	CS	FC	RS	CS	FC	CS	FC	(1)
15-24	.037	.109	.068	.073	.150	.060	.000	.062	.100	.083	.000	
25-44	.074	.171	.230	.073	.210	.100	.056	.160	.120	.190	.073	
45+	.070	.160	.143	.082	.145	.266	.205	.181	.193	.190	.041	

Table 16: Proportional responses to diphthongization of four vocalic elements by age and style.

(1) There were no examples provided by reading style to represent long /ɔ/

The phenomenon of diphthongization is very stable for each group in all contextual styles. The younger informants diphthongize between 6% and 15% of all vocalic elements in careful style, between 0% and 10% in formal conversation, and between 0% and 7% in reading style. The informants aged between 25-44 diphthongize between 16% and 21% of all vocalic elements in careful style, between 7% and 23% in formal conversation, and between 5% and 7% in reading style. The older informants use diphthongization around 14% and 19% of all vocalic segments in careful style and formal conversation, and between 7% and 20% in reading style.

Apart from the half-open back rounded phoneme /ɔ / in formal conversation, which is significantly less diphthongized than the other vocalic segments, all other cases, where diphthongization is likely to occur, reflect a very regular structure. Each age group uses diphthongization regularly according to the contextual style. When, for example, young informants diphthongize /ɛ / +r at a 10% level in careful style, they also diphthongize /ɑ /, /œ / +r, /ɔ / +r at about the same level in the same style.

A vowel may be more or less diphthongized according to the context in which it occurs, but a vowel does not seem to be more diphthongized because it is half-open, or unrounded, etc., i.e. because of its phonetic characteristics. Thus, all vowels are equally liable to become diphthongized.

As for /ɛ / [+long] historically and lexically, an interesting difference between age groups is to be observed; in all contextual styles and for all vocalic elements, young informants diphthongize the long vocalic elements less often than their older counterparts.

The differences between informants aged between 25-44 and those aged 45 and over are not regular. Sometimes these two groups behave in the same way towards diphthongization, sometimes the older group uses diphthongization more often than the middle-aged one, and sometimes the latter exceeds the older group in its use of a diphthongized segment.

However, what appears clearly from figure 15 and table 16 is that young informants use diphthongization less often than all older informants whatever the vocalic element and the contextual style involved. A linguistic change seems to be in progress as far as diphthongization as a whole is concerned. Reduction in the incidence of the phenomenon takes place when young speakers are considered.

Before drawing more definite conclusions, however, the remaining sociological parameters will be investigated.

2.4.3.2 Differentiation by education

Chi Square and Exact Value tests give strong evidence against the hypothesis of similar behaviour by all educational groups. As for variable (a)-1 and archaic phonetic features, the most important discrepancy affects ed.1,2 compared with ed.3,4. The results obtained in studying the behaviour of these four groups towards diphthongization of long vocalic segments can be seen in table 17.

Tendencies revealed earlier in the two preceding tables still hold good. Thus, it can be observed that each

		/ɛ/	/ɛ/tr	/a/	/æ/tr	/ɔ/tr
ed.1	RS	.100	.000	.000	.000	---
	CS	.270	.028	.055	.036	.048
	FC	.139	.000	.000	.031	.000
ed.2	RS	.270	.060	.000	.052	---
	CS	.390	.069	.078	.075	.125
	FC	.342	.069	.130	.054	.066
ed.3	RS	.466	.110	.265	.000	---
	CS	.730	.334	.400	.134	.175
	FC	.620	.200	.200	.280	.000
ed.4	RS	.720	.139	.220	.364	---
	CS	.760	.382	.440	.381	.355
	FC	.600	.384	.350	.427	.125

Table 17: Proportional responses to diphthongization by environments, education and style.

group diphthongized /ɛ/ much more when it is long historically and when its length is lexically determined, than when it is followed by /r/. It is also true that diphthongization affects /ɛ/ more often than any other vocalic element.

It can moreover be noticed that, almost without exception, the diphthongization rate for each form follows the order: ed.1 < ed.2 < ed.3 < ed.4, i.e. more educated informants generally diphthongize long vocalic elements less often than less educated informants, and young informants make use of diphthongized segments less often than their older counterparts.

Once more, a very regular structure appears. Ed.4, for example, is the group using diphthongization the most often in all styles and for all vocalic elements.

Another tendency similar to that seen in the comparison of age groups is that careful style seems the style favouring the highest incidence of diphthongized vocalic elements. This tendency can be seen in table 17 in fourteen cases out of twenty. In the remaining six cases, a group displays either a similar pattern of behaviour in all contextual styles (cf. ed.2 for /ɛ/ + r , and ed.4 for /œ/ + r) , showing no style shifting, or an increase in their use of diphthongized elements as they move to a less formal speech situation. This is the case for ed.3 for /œ/ + r , and for ed.2 when long /a/ is considered. Or else, there is no difference between careful style and formal conversation, as this can be observed for ed.1 for /œ/ + r and ed.4 for /ɛ/ + r.

Generally, however, careful style, in which attention is focused on pronunciation and words are spoken in isolation, appears to be the most favourable context to elicit higher occurrences of diphthongization.

On the other hand, reading style is also a style in which special attention is focused on pronunciation, but where words occur in connected speech. If attention given to pronunciation was the main factor in explaining stylistic differentiations, similar results as those found for careful style would be expected in reading style. This has been the case in the study of co-variation of [a] - [ɔ] , in which no important differences were found between the two more careful styles of speech. Groups behaved in the same way in these two contextual styles, i.e. in a formal speech situation, as opposed to their pattern of behaviour in a less formal context.

The pattern offered by the study of diphthongization is however different. In reading style, diphthongization is nearly always the least often realized by all groups, and therefore attention focused on pronunciation has certainly a part to play when reading style is considered.

On the other hand, the fact that words are pronounced in connected speech is also an important factor to be taken into account. In six cases out of twenty, i.e. ed.1 towards /ɛ/, /ɛ/ + r, and /a/, ed.2 towards /ɛ/ + r, /œ/ + r, and ed.3 towards /a/, the percentage of diphthongized elements is about the same in reading style and formal conversation. In these cases, connected speech seems the important factor accounting for less incidence of diphthongization, and not attention paid to pronunciation.

Another fact which confirms this relationship is that, in ten cases, diphthongization of a vocalic element is realized at almost the same level in formal conversation and careful style. In formal conversation, the percentage of diphthongized elements may be somewhat lower or higher than in careful style, but the results are nevertheless sufficiently close to prevent a clear distinction being drawn between these two styles. This lack of discrepancy between two different speech situations is probably explained by the following factors.

Words pronounced in isolation combined with attention focused on pronunciation lead to a level of diphthongization which is different for every educational group in careful style. Less or no attention focused on pronunciation combined with words occurring in connected speech lead to a similar pattern, in which diphthongization may be realized

in formal conversation at a similar level to that obtained in careful style, and where groups are differentiated at the same level of significance in both styles. In formal conversation, lack of attention paid to pronunciation seems to be compensated for by the fact that words occur in connected speech, so that a similar pattern of behaviour occurs as that observed in careful style.

The stylistic variations can thus be explained both in terms of awareness of the phenomenon of diphthongization and syntactic conditioning. It nevertheless remains true that differences between the three contextual styles are often very low and not significant from a statistical point of view. The slight differences present might only indicate tendencies of speakers and not real discrepancies, as those found in the study of variable (a)-1 and archaic phonetic features.

There is only one instance where a significant style shifting is to be observed, i.e. for ed.3 towards /œ/ + r. In this case, the percentage of diphthongization increases significantly as one moves from the most careful speech style to the least formal one. Since less educated informants use diphthongization more often, they might also be more aware of it and try to correct it in more careful styles. This awareness seems however represented only in one case out of ten, in which diphthongization decreases according to the formality of the speech situation. In addition, four other cases are of interest, in that speakers of ed. 3 diphthongized /ɛ/ and /ɛ/ +r , and ed.4 /ɑ/ and /ɛ/ +r significantly less often in reading style compared with formal conversation. In these five cases, less educated speakers show awareness of this linguistic phenomenon by using less diphthongized vocalic elements when realizing long vocalic segments in reading style.

Indications of a linguistic change observed in the study of the age variable are confirmed in this latter study. The age factor again plays a part, in that young informants generally diphthongize less often than their older counterparts, although the differences are not always very important. Depending on the vowel concerned, the differences between the two age groups can be striking or not. When more educated informants are compared for example, the most important age difference occurs when the vowel most often diphthongized is considered, i.e. phonetically and lexically determined long /ɛ/. Where less educated informants are concerned, indications of a linguistic change in progress are seen in the case of /œ/ +r, and /ɔ/ +r, in all contextual styles, with long /a/ and /ɛ/ +r in formal conversation, and finally in the case of long /ɛ/, except when followed by /r/, in reading style. In the remaining environments and contextual styles, both age groups display a similar pattern of behaviour. Generally, however, there are sufficient indications to permit the assumption that the younger the speaker, the more diphthongization of long vocalic segments is decreasing.

The age factor is however complicated here by an educational factor, since more educated informants in general use diphthongization significantly less often than less educated informants in all cases. A brief investigation of another type of educational grouping will further illustrate this fact.

As the following table illustrates, the speakers are greatly differentiated according to their educational background. Those having 13 or more years of education show the least diphthongization of all vocalic segments in all contextual styles. Those who have had 9 or fewer years of

schooling use diphthongized vowels the most often for all vocalic elements and contextual styles. Finally, the informants who have had between 10-12 years attendance at school fall in between these two groups, sometimes showing a pattern of behaviour approaching that of the more educated informants, sometimes one which approaches more that of the less educated informants.

	13+			10-12			9-		
	RS	CS	FC	RS	CS	FC	RS	CS	FC
/ɛ/	10%	38%	19%	40%	45%	47%	58%	58%	50%
/ɛ/ +r	2%	10%	7%	8%	19%	10%	13%	40%	37%
/a/	0%	12%	6%	9%	26%	20%	31%	42%	37%
/œ/ +r	0%	11%	7%	11%	30%	10%	22%	60%	37%
/ɔ/ +r	--	12%	0%	--	28%	5%	--	37%	13%

Table 18: % of responses to diphthongized vocalic segments by environment, education and style.

The regularity of the structure is striking. All groups are differentiated at the same level of significance in all styles of speech and in the realization of each vocalic element. There is no deviation from the regular structure. All groups are coherent in their use of diphthongization.

There is not only a regularity in educational stratification, but also an interesting consistency in the percentage of diphthongized elements each group uses. In each contextual style, except for /ɛ/ not followed by /r/, the use of diphthongized vocalic segments remains constant. The informants who have had 13 or more years of education, for example, diphthongize all vocalic elements between 10% and 12% of the time in careful style. This again confirms the assertion that diphthongization is a general mode of articulation which is regularly realized for every group. The rate to which it is realized depends on the contextual style in which it occurs and on the social characteristics of the speakers.

Not all contextual styles are significant in accounting for the awareness speakers may have of a linguistic feature carrying prestige. If this were the case, one would expect a decrease in the use of diphthongization in both more careful styles. Such a reduction can be observed in reading style; but usually there is either no style shifting, or, when a style shifting is observed, it is rather the opposition of words in isolation v. words in connected speech which accounts best for the style shifting present.

Now that phenomenon of diphthongization has been correlated with the educational and age parameters, occupation and sex factors will be considered in order to determine whether the same relationships between styles and groups as those found in the study of the preceding sociological parameters still hold good.

2.4.3.3 Differentiation by occupation and sex.

		Professionals		white collar workers		manual workers	
		M	F	M	F	M	F
/ɛ/	RS	10%	9.9%	33%	33%	50%	83%
	CS	28%	20%	36%	47%	68%	82%
	FC	10%	17%	37%	50%	52%	70%
/ɛ/ +r	RS	0%	0%	6.6%	6.6%	10%	16%
	CS	6%	6%	3%	3%	15%	54%
	FC	5%	3%	6%	6%	6%	54%
/ɑ/	RS	0%	0%	3%	0%	13%	30%
	CS	3%	2%	9%	8%	35%	47%
	FC	5%	11%	6%	14%	6%	50%
/œ/ +r	RS	0%	0%	0%	5%	20%	30%
	CS	5%	2%	6%	9%	14%	42%
	FC	0%	0%	8%	6%	18%	50%
/ɔ/ +r	CS	8%	5%	13%	11%	23%	34%
	FC	0%	0%	10%	0%	0%	15%

Table 19: % of responses to diphthongization by environment, occupation, sex and style.

Diphthongization of long /ɛ/, except when followed by /r/, is the only case offering a clear-cut discrepancy between the three occupational groups. Professionals are those who diphthongize the least, followed by white collar workers and finally by manual workers. As seen in the study of the age

and education parameters, speakers do not seem to be aware of their use of a diphthongized /ɛ/. They show either no important style shifting, or they use diphthongization to an equal proportion in reading style and formal conversation, or in careful style and formal conversation. The groups who use diphthongized segments less in reading style, probably also show an awareness of this type of articulation, since this style is the most formal of all styles elicited in the interviews.

Generally, however, groups do not demonstrate by their behaviour that they are much aware of a necessity to use diphthongs less when realizing /ɛ/ in more formal speech situations.

When considering the remaining vocalic elements, groups are not differentiated in the same way. The important differences now concern professionals and white collar workers as opposed to manual workers. This latter group is the only one behaving differently from the two others towards diphthongization. Thus generally, use of more diphthongs would be expected from manual workers.

The sex differentiation is not so important where professionals and white collar workers are concerned. Men and women usually have a similar pattern of behaviour towards diphthongization. Only female white collar workers diphthongize long /ɛ/ significantly more than their male counterparts in careful style and formal conversation. In all other cases, no sex differentiation affects professional and white collar worker groups.

When manual workers are considered, however, strong

evidence is provided against equal proportional response by each sex group towards diphthongization. Women of this occupational group diphthongize all vocalic elements significantly more often than men in all styles of speech. This again confirms the finding that groups are very consistent in their use of the phenomenon of diphthongization. Women of this occupational group form the sub-group accounting for the most important discrepancy. Their male counterparts, in fact, behave very similarly to the two other occupational groups, mainly in formal conversation.

The study of occupational and sex groups gives less clear-cut indications of social stratification than did educational groups. On the other hand, study of these two factors demonstrates that use of diphthongization seems to be decreasing significantly within the population. Only women of the manual worker group diphthongize all vocalic elements frequently. All other groups make use of this type of articulation at a low level, except for /ɛ/ which is still strongly diphthongized.

Another fact which is interesting to note is that male manual workers have a pattern of behaviour approaching that of other occupational groups when formal conversation is considered. In the two careful styles, however, they are differentiated from them by diphthongizing significantly more often. This behaviour is probably due to a lack of awareness of the phenomenon of diphthongization observed in all groups.

Examples of speech will illustrate how speakers use diphthongization when they realize a long vocalic element. The first series of examples concerns words spoken in careful style. Since these words were the same for all speakers, it will illustrate different patterns of behaviour towards

diphthongization more effectively. All words given as examples occurred in a syntactically prominent position and were spoken in isolation by the informants. The words taken as examples are : tard, pâte, baille, seize, tête, verre, fleur, peur, cœur, corps, mort, dort.

Professionals

15-24 years of age

M.1.2 [ta:ʋ pb:t bʋ:j sɛ^I:z tɛ:t vɛ:ʋ flœ̃:ʋ pœ:ʋ
kœ̃:ʋ kɔ:ʋ mɔ:ʋ dɔ:]

F.1.2 [tä:ʋ pa:t ba:j sɛ^I:z tɛ:t vɛ:ʋ flœ̃:ʋ pœ̃:ʋ
kœ̃:ʋ kb^v:ʋ mɔ:ʋ dɔ:ʋ]

25-44

M.1.4 [tɔ^r:r pɔ^t:t bɔ:j sɛ^I:z tɛ^I:t vɛ:ʋ flœ̃:ʋ pœ:ʋ
kʲœ̃:ʋ kɔ:ʋ mɔ:ʋ dɔ:ʋ]

F.1.5 [ta:ʋ pa:t ba:j sɛ:z tɛ̃:t vɛ̃:ʋ flœ̃:ʋ pœ̃:ʋ
kœ̃:ʋ kɔ:ʋ mɔ:ʋ dɔ:ʋ]

45+

M.1.7 [tɔ:ʋ pa:t ba:j sɛ^I:z tɛ:t vɛ^I:ʋ flõ:ʋ pœ^Y:ʋ
k^hœ̃:ʋ kɔ:ʋ mɔ:ʋ dɔ:ʋ]

F.1.10 [tA^v:ʋ pA:t bA:j sɛ^I:z tɛ^I:t vɛ^I:ʋ flœ̃:ʋ pœ^a:ʋ
kœ:ʋ kɔ:ʋ mɔ^v:ʋ dɔ:ʋ]

White collar workers

15-24

M.2.1 [ta^o pa:t bɔ̃:j sɛ:z tɛ²:ʋ vɛ^o flA^o pœ̃:
kœ^o kɔ^o mɔ^o dɔ^o]

F.2.1 [tä:ʙ pa:t ba:j sɛ̃^I:z tɛ̃^I:t vɛ̃:ʙ floe:
pœ̃^h: kœ̃^ʙ: kɔ̃:ʙ mɔ̃:ʙ dɔ̃:ʙ]

25-44

M.2.4 [ta^v:ɹ pa^v: bɔ̃:j sɛ̃^I:z tɛ̃^I:t vɛ̃: floe:ɹ
pœ̃^ʎ: kœ̃^ʎ:R kɔ̃^v: mɔ̃^v: dɔ̃^ʙ]

F.2.4 [ta:ʙ pa^v:t ba:j sɛ̃^I:z tɛ̃^ʙ:t vɛ̃:ʙ flœ̃^ʙ:ʙ
pœ̃^ʙ:ʙ kœ̃^ʎ:R kɔ̃:ʙ mɔ̃:ʙ dɔ̃^ʙ]

45+

M.2.10 [tɔ̃:ɹ pa^v:t bɔ̃:j sɛ̃^I:z tɛ̃^I:t vɛ̃:r floe:
pœ̃^ʎ: kœ̃^ʎ: kɔ̃: mɔ̃:ɹ dɔ̃:ɹ]

F.2.10 [ta:ʙ pa:t ba:j sɛ̃^I:z tɛ̃^I:t vɛ̃:ɹ floe:ɹ
pœ̃^ʎ: kœ̃^ʎ: kɔ̃: mɔ̃^ʙ:ʙ dɔ̃:ɹ]

Manual workers15-24

M.3.1 [tɔ̃^ʙ pɔ̃:t ba:j sɛ̃^I:z tɛ̃:t vɛ̃: flɔ̃:
pœ̃^ʙ kɔ̃^ʎ kɔ̃:h mɔ̃^ʙ dɔ̃^ʙ]

F.3.1 [ta^v:ʙ pa^v:t ba^ʙ:j sɛ̃^I:z tɛ̃^I:t vɛ̃^ʙ: flɔ̃^ʙ:
pœ̃: kœ̃: kɔ̃^v:ʙ mɔ̃^v:ʙ dɔ̃:]

25-44

M.3.4 [tɔ̃:ɹ pa^v:t ba^v:j sɛ̃^I:z tɛ̃^I:t vɛ̃^I:ɹ flœ̃^ʙ:
pœ̃^ʎ:ɹ kœ̃^ʎ: kɔ̃^v: mɔ̃^ʙ:ɹ dɔ̃^v:ɹ]

F.3.4 [tɔ̃:ʙ pa^v:t ba^v:j sɛ̃^I:z tɛ̃^I:t vɛ̃^I:ʙ flœ̃^ʙ:ʙ
pœ̃^ʙ:ʙ kœ̃^ʎ:ʙ kɔ̃:ʙ mɔ̃:ʙ dɔ̃:ʙ]

45+

M.3.10 [t^h: pa^v: b^h:j s^h:z^h t^h: v^h: fl^h:
 .p^h:h k^h: kb^v: mv: d^h:]

F.3.7 [ta^v: pa^v:t b^h:j sae^h:z^h t^h:t v^h:r^h fl^h:^v:
 p^h: k^h: kb^v:r^h mv^v: dv^v:]

These examples of a few speakers give a somewhat arbitrary idea of the phenomenon of diphthongization. In fact, not all speakers are represented and furthermore, not all the words containing long vocalic elements could be given as examples. One speaker may for example diphthongize /a/ in pâte, but not in pâle, etc. Nevertheless, the few examples given above illustrate what has been found when groups of speakers were considered. Young speakers usually appear to diphthongize less often than older informants for example, and less educated speakers and manual workers use diphthongized segments much more often than more educated informants, etc.

A second series of examples will now be given in order to illustrate the behaviour of different speakers towards diphthongization in formal conversation.

Professionals15-24

M.1.1 [se ävek so ʒ-vom sät^siR la p^hy z a l^h:z^h]
 "C'est avec ça que je vais me sentir le plus à l'aise".

[l^hfb:ʊ k^h v^h met lb / sa va ɛt l^hfb^h p^hu^h
 ɛsɛje da bjɛ p^hɔn^hɔse]

"l'effort qu'on va mettre, là, ça va être l'effort pour essayer de bien prononcer".

F.1.1 [pi lɔ̃ javɛ œ nɔ̃m dã• fnɛ•t]
 "Puis là, il y avait un homme dans la fenêtre"

[ø RAVNE VE•R TRWA RIVJË:]
 "Eux revenaient vers Trois-Rivières".

25-44

M.1.5 [zavɛ rãkɔ̃tre ʏn frãsɛ:z / setɛ ʏn mart^sinikɛ•z]
 "j'avais rencontré une française. C'était une martiniquaise".

[pɔ skɔ•se la tɛ•t]
 " Pas se casser la tête".

F.1.4 [jɔ̃ tvʒv:f la pɛrsɔ̃n ki pa•l dʏn setɛn manjɛ:r]
 "Il y a toujours la personne qui parle d'une certaine manière".

[pʃɔ̃ tvʒv la lã:g sʏpɛrjœ:r]
 "puis, il y a toujours la langue supérieure".

[bɛ pɔtɛ^I:t]
 "bien, peut-être".

45+

M.1.9 [me t^hud mɛ:m]
 "mais tout de même".

[se bjɛ pɛɾsɔ̃nɛl / me t^hud mɛ^I:m]
 "c'est bien personnel, mais tout de même".

[ɔ̃nɛ t ale vwa•l de pjɛs də teɑ^v:t]
 " on est allé voir des pièces de théâtre".

F.1.7 [ʏn sɛɾtɛn glwã:d]
 " une certaine gloire".

[wɪ pɔtɛ^I:t]
 " Oui, peut-être".

[lə ply dla ba^v:z lɔ̃]
 "le plus de la base, là".

[t^sy pø tə fɛ̃ː rəkɔ̃nɛ̃ːt]
 "tu peux te faire reconnaître".

White collar workers

15-24

M.2.2 [a lɛksterjœ:] "A l'extérieur"
 [le kuzɛ̃ dma mɛ̃ːb] "Les cousins de ma mère".
 [ssãtsɪ pøtɛ̃ːt ply z a lɛ̃ːz avɛk lui]
 "se sentir peut-être plus à l'aise avec lui".

F.2.2 [mɛ̃ːm / sa labɛ̃ːs {truv}]
 "même, ça l'abaisse, je trouve".
 [parle a la frãsẽːz] "Parler à la française".
 [ɛlarʒɪr nõtɾa vokabyɛ̃ːr] "Elargir notre vocabulaire".

25-44

M.2.5 [mɛ̃ːm nɔ̃] "même, non".
 [loːtra mɛ̃ːr] "l'autre mer".
 F.2.4 [wi pøtɛ̃ːt] "Oui, peut-être".
 [sɛ̃t manjɛ̃ː lb̃] "cette manière là".
 [me kã mɛ̃ːm] "Mais quand même".

45+

M.2.7 [i fazæ katra vɛ̃ degre d̃ {alœ̃ː}]
 "Il faisait 80 degrés de chaleur".
 [kɔ̃ n ãliːz dã la nɛ̃ːʒ]
 "qu'on enlise dans la neige".

On two other occasions, he pronounced neige as [nɛ̃ːʒ]

- F.2.9 [sʏr ʏn bʏt də nɛʔ:z] "Sur une butte de neige".
 [fɛ̃ ivɛ:r] "fin hiver".
 [ʒ dʒirɛ kle mɔ̃realɛ:z u le kɛ̃bɛ̃kwa:z]
 "je dirais que les montréalaises ou les québécoises..."

Manual workers

15-24

- M.3.3 [sa ko:z patɛ•t œ prɔ̃blɛʔ:m]
 "ça cause peut-être un problème".
 [ɔ̃pɔ•s pʏr de ʒã kɔ̃mœ u vʏlgɛ:ɛ]
 "on passe pour des gens communs ou vulgaires".
 F.3.3 [ʒã dɔ̃nrɛ̃ ä ma mɛʔ: / la trwɔ kɔ̃•r] [a ma me:]
 "j'en donnerais à ma mère; les trois-quarts". "à ma mère".
 [tʂʏt sɔ̃rt dafɛ• da mɛ̃ʔ:]
 "toute sorte d'affaires de même".

25-44

- M.3.6 [kɔ̃m nu ɔ̃ twɔ rivjɛʔ:r]
 "comme nous de Trois-Rivières".
 [pi ki vɔ̃ mɛʔ:m / kɔ̃ vɔ̃ mɛʔ:m pʔy lwɛ̃ k kebɛk]
 "Puis qui vont même, qu'on va même plus loin que Québec".
 [sa vɔ̃ dʒɪ• la mɛʔ•m ɔ:z]
 "ça veut dire la même chose".
 [ʏn klɔ̃:s uʋrijɛ:]
 "une classe ouvrière".
 F.3.5 [pɔ̃ dʒɪrɛktɔ̃mã ɔ̃ twɔ rvjɛ:R]
 "pas directement de Trois-Rivières".

[puvɛ pɔ dʒɪ kə ʃ vnɛd̥ tʷo rʋjɛɪ̯]

"(ils ne) pouvaient pas dire qu'on venait de Trois-Rivières".

[sɑ depã osi dla klaʋ:s]

"ça dépend aussi de la classe".

45+

M.3.9 [nʃ / avɛk sã vɛtʳɛ mɪ dʃɪbʋ: / ɛ n afɛ kə x frɛ /
/.../ ɛ noʔt afɛɪ̯:]

"Non, avec \$125,000 dollars, une affaire que je ferais...
Une autre affaire..."

[ɛ n arjɛɪ̯]

"En arrière".

[setɛ pakæ d̥ flaʋ:m]

"c'était un paquet de flammes".

F.3.8 [pax kəlahã fæ pɔl bɔnɔɛ:]

"parce que l'argent (ne) fait pas le bonheur".

[ʒanne y dlɛglatɛ:]

"j'en ai eu de l'Angleterre".

[əʒe dʒi sɛd valɔɛ:]

"j'ai dit, c'est de valeur".

[dlɛ likɔɛ:]

"de la liqueur".

[ʒe dmãde ʋn sɔrt dafɛɪ̯:]

"j'ai demandé une sorte d'affaire".

[mɔ grã rɛ:v]

"mon grand rêve".

These examples illustrate that, in general, long vowels will be more liable to be diphthongized when occurring in a syntactically prominent position. Differences between various speakers according to their social background are also portrayed through these examples, although they are not always easy to see, since not all words containing long vowels could be given for each informant.

From the study of the phenomenon of diphthongization, conclusions can be drawn on the type of linguistic, social and stylistic structures emerging from this type of articulation.

2.4.3.4 Conclusions

1- Linguistic structure

When studying diphthongization, four different vocalic elements have been considered. These vowels are formed from various combinations of the three principal characteristics involved in vowel formation, i.e. $\begin{bmatrix} + \\ - \end{bmatrix}$ round, $\begin{bmatrix} + \\ - \end{bmatrix}$ front, and $\begin{bmatrix} + \\ - \end{bmatrix}$ open. All of these vocalic elements are liable to various phonetic realizations, diphthongization being one of them.

One phonetic conditioning seems to affect the degree to which diphthongization will be realized, when the vowels are found in a lengthening phonetic context. The half-open unrounded /ɛ/ is in fact the only vocalic segment segregated at a significant level from the remaining vowels. When this vowel is long, i.e. when followed by /v(r),z,ʒ/ and when its length is lexically determined, it is diphthongized significantly more often than when it is followed by /r/ and all other long vocalic elements. It is the most frequently diphthongized segment in all contextual styles and by all informants.

In formal conversation, the half-open back rounded vowel is the least diphthongized of all vocalic elements by all groups. Since diphthongization of /ɔ/ is not often used

in this contextual style, it is also in this vocalic element that the differentiation between speakers is at the lowest level, whereas with long /ɛ/, the most frequently diphthongized segment, the highest discrepancies between various groups of speakers were found.

The remaining vocalic segments, i.e. /ɛ/ +r, long /a/, and /œ/ +r, are diphthongized to about the same degree by all groups in this contextual style.

As for the study of variable (a)-1 and that of archaic phonetic features, two stylistic structures should be considered: one for formal conversation, approximating to the native speech pattern acquired in early years, and one for the more formal speech styles, which approximate to the subjective norms of the speaker in so far as he has attained some degree of control over them.

The linguistic structure given by formal conversation, in which /ɛ/ is the most frequently diphthongized element, and /ɔ/ the least, and in which the remaining vocalic segments are diphthongized to nearly the same degree by all groups considered, does not alter considerably where careful style is concerned.

In this contextual style, the percentage of usage of diphthongization increases, probably due to the fact that words were spoken in isolation, but the linguistic pattern remains more or less the same. /ɛ/ remains the most frequently diphthongized segment, while all others are consistently diphthongized to the same degree by all groups. For example, ed.4 diphthongized /ɛ/ +r at 38%, /a/ at 44%, /ɔ/ +r at 35% and /œ/ +r at 38%; professionals diphthongized these vocalic segments in the order 13%, 13%, 16%, and 13%, etc.

The regularity is striking for most groups considered.

In reading style, the percentage of diphthongized vocalic elements decreases compared with that of careful style. Nevertheless, the linguistic structure remains the same. /ɛ/ is still the vowel most frequently diphthongized, whereas /e/ +r, long /a/, and /œ/ +r are usually diphthongized to about the same degree by various groups. There are few exceptions in this style, in that ed.3, for example, never diphthongized /œ/ +r in this contextual style, while using diphthongization at a fairly high level for the other vocalic elements. In addition, ed.4, manual workers and those with 9 or fewer years of schooling diphthongized /ɛ/ +r less often than /a/ and /œ/ +r.

It is nevertheless the case that the phenomenon of diphthongization can be viewed as stable, i.e. that each group diphthongizes long vocalic segments to about the same degree depending on the context involved. The phonetic realization involving segmentation of a long vocalic segment by means of opening the initial segment and moving to a closer element in the same vocalic area has affected all long vocalic elements to the same degree. Whatever the contextual style involved, all long vowels are liable to be diphthongized and moreover, except for long /ɛ/ not followed by /r/, all are diphthongized at the same rate. This indicates a regularity in the phonetic system, by means of which all segments of the vocalic system are equally affected by the length feature, as far as diphthongization is concerned.

2- Social structure

Through a sampling of the speech of individuals charted along the axis of social variation, another structure

has emerged.

The most important discrepancies are found when educational groups are compared. The type of grouping offering the most regular structure is that obtained when the three educational groups are considered, i.e. the informants having 13 or more years of schooling, those who have had between 10 and 12 years attendance at school, and finally the speakers having 9 or fewer years of education. The relationships between any of these three groups with the others, in all contextual styles, and for all long vocalic elements studied, remain constant. The significant ordering has always the same pattern, i.e. 13 + < 10-12 < 9-. A very regular social structure emerges when comparison of these three educational groups is made. All groups are in fact differentiated at the same level of significance whatever the contextual style and the vocalic element considered. Thus, the relations between any given term and the others could be predicted if that term were missing from the data.

This is the only type of grouping displaying such a regular social structure. Elsewhere, some deviations from this structure are to be observed, i.e. the inequalities or differences between groups are either reversed or become equalities.

When taking the four educational groups into account, the following patterns of behaviour occur. Usually, ed.1 and 2 are clearly differentiated from ed.3 and 4. Only for /œ/ in reading style and for /ɔ/ in formal conversation is an equality to be seen, in that young, less educated speakers (ed.3) make use of a diphthongized segment at the same level as the more educated informants. This can be

considered as a deviation from the regular structure, since less educated speakers are generally expected to diphthongize long vowels more often than more educated informants.

This expectation is nevertheless true most of the time in that older, less educated speakers diphthongize all vocalic segments consistently the most frequently in all styles. Younger, less educated informants are differentiated from their older counterparts by diphthongizing significantly less often for /ɛ/ in reading style, /a/ in formal conversation, and for /œ/ and /ɔ/ in all styles.

Younger, more educated informants are also differentiated from their older counterparts by consistently diphthongizing the least often. The differences between ed.1 and ed.2 are, however, not always significant. They are important in the case of long /ɛ/ in all styles, of long /a/ in formal conversation, and finally in the case of long /ɔ/ in careful style. Elsewhere, young, more educated informants, although using diphthongization less often, are not differentiated that much from their older counterparts, since these latter diphthongize at a very low level.

Although some deviations from a regular structure of the type : ed.1 < ed.2 < ed.3 < ed.4 are to be observed, it is the case that the structure offered by this type of grouping also has regularity: ed.1 is always the group diphthongizing the least and ed.4 always the one making the most frequent use of a diphthongized segment. Ed.2 behaves either as ed.1, or falls in between ed.1 and ed.3. Ed.3 behaves either as ed.1 and ed.2, either as ed.4, or falls in between these two groups.

When occupational and sex groups are considered, some deviations also occur in the structure. It is when the most frequently diphthongized vocalic element is considered that the most regular inequalities between groups are to be observed. Long /ɛ/, not followed by /r/, is the only case in which a very clear difference between occupational groups is to be seen. Professionals diphthongize the least, followed by white collar workers, then by male manual workers, and finally by female manual workers.

For the remaining vocalic elements, the differences present between groups are often below a 10% level, and are therefore not very significant. Nevertheless, it can regularly be expected that professionals and white collar workers, male and female, will make use of a diphthongized segment at about the same level, whatever the contextual style or the vowel involved, except for long /ɛ/, when not followed by /r/.

In addition, it can be regularly expected that female manual workers will use diphthongization significantly more often than any other group.

Male manual workers behave usually like the other occupational groups when realizing a long vocalic element in formal conversation. Furthermore, male manual workers will usually fall between the two other occupational groups and their female counterparts, by diphthongizing long vocalic elements in careful style and reading style more often than the former and less often than the latter.

From the observation of various types of grouping, regular relationships between groups of speakers appear, although deviations are to be seen:

a) there are no groups who never diphthongize a long vocalic element; nor are there any who always preserve diphthongization: it is a case of inherent variation.

b) for every group, diphthongization is regularly realized. The degree in the incidence of diphthongization indicates significant differences between groups of speakers.

Young, more educated informants, more educated informants in general, professionals and white collar workers use diphthongization significantly less often than less educated informants, female manual workers, etc. The differences between groups is significant because of the degree to which diphthongization is realized and not because of categorical differences.

When considering the age factor, indications of a linguistic change in progress appear. Although differences between age groups are not always very large, it is evident that informants aged between 15-24 always diphthongize a long vocalic segment the least whatever the contextual style involved.

If the process of linguistic change was regular, a decrease in the incidence of diphthongized segments would also appear where informants aged between 25-44 are compared with the oldest group. This is the case only for long /ɛ/ in reading and careful styles, for /ɑ/ in formal conversation, and for /œ/ in reading style and formal conversation. Elsewhere, these two age groups behave either in the same way, inequalities becoming equalities, or inequalities are reversed, i.e. older informants diphthongize significantly less often than the middle-age group.

A sound change, or rather a change in the degree to which a certain phonetic phenomenon will be realized, usually originates with a restricted sub-group of the speech community: Diphthongization of long vocalic elements has probably existed for a long time, co-varying with other phonetic realizations of these vocalic segments. The degree to which it will be used seems to be decreasing significantly, especially with young, more educated informants.

Although not presenting a regular decrease from one generation to an other, incidence of diphthongization is nevertheless decreasing in younger speakers. This group can be seen as the leading one in the change affecting diphthongization.

3- Stylistic structure

When behaviour of groups of speakers are charted along the axis of stylistic variation, another type of structure emerges.

In the study of variable (a)-1 and archaic phonetic features, it was observed that the opposition of formal v. less formal styles of speech was the important factor in accounting for stylistic variation. As one moved from more careful styles to less formal ones, a significant increase in the incidence of [ɔ] and of archaic features occurred. In more careful speech styles, it appeared that open back unrounded [ɑ] became the favoured form as well as more common standard French forms rather than archaic ones.

When studying the phenomenon of diphthongization, however, a different relationship between speech styles appears.

The only style in which reduction in the incidence of diphthongization is regularly to be seen is reading style. In this style, attention is focused on pronunciation and words occur in connected speech. The combination of these two factors permits the assumption that, in the context of reading a prepared text, speakers are generally expected to diphthongize long vocalic elements the least often.

In careful style, however, attention is also focused on pronunciation, but words are spoken in isolation by the informants. Most of the time, it is in this style that the occurrence of diphthongized segments is at the highest level. This is probably due to the fact that the phenomenon of diphthongization has not risen to social awareness so much, at least not as much as variable (a)-l and archaic phonetic features. Awareness of this phonetic phenomenon can probably be viewed best through the behaviour of informants in reading style.

Formal conversation, in which the least attention is focused on pronunciation, gives results nearing those obtained either in reading style, or in careful style.

Differences in the percentage of occurrence of diphthongized segments occur between these various speech styles. Most of the time, however, these differences are very small, being near a 10% level of discrepancy.

From the analysis of speech styles, the following conclusions may be drawn:

- most of the time, diphthongization is realized more often when words are spoken in isolation than when they occur in connected speech.

- in connected speech, diphthongization is realized less often when words occur in a prepared reading text (reading style) , than when they are spoken in a more spontaneous context (formal conversation) .

Diphthongization of long vowels is a phenomenon in co-variation with other types of articulation. It is a mode of articulation realized by all groups and the degree to which it will occur depends on the contextual style and the social characteristic of the speaker.

Speakers seem relatively unaware of the social implications of diphthongization and therefore show either little stylistic shifting, or when style shifting is present, there is generally no consistent progression in the incidence of diphthongization from reading to careful style, and thereafter to formal conversation.

Diphthongization of long vowels is not a phenomenon overtly stigmatized or discouraged by educational institutions, at least not as archaic phonetic features are. This type of articulation is involved in linguistic change, in which younger, more educated informants appear to be the leading group. However, this change does not seem to have affected all groups to the same degree. These two factors probably explain the irregular distribution of diphthongization along the axis of stylistic variation. The change in the habit of articulation involving reduction of diphthongized segments has not completely risen to full consciousness and has not affected all speakers to the same degree. Therefore, an irregularity in the relationships between different speech styles is understandable.

2.4.3.5 Summary

The study of diphthongization has revealed regular types of structure:

- 1- a regular phonetic structure in which all long vocalic segments are equally liable to become diphthongized, and in which all long vocalic segments are diphthongized to the same degree depending on the contextual style, except in the case of long /ɛ / , not followed by /r/;
- 2- groups of speakers are differentiated in their use of diphthongized segments in a regular way. The more they diphthongize , i.e. in careful style, the more the differences are striking and vice-versa. In addition, a group diphthongizing the most will usually diphthongize all long vocalic elements the most often in all styles, and conversely.
- 3- the relationship between speech styles is generally as follows: reading style is the style in which less incidence of diphthongized segments is to be expected; careful style is the one in which the most occurrences of diphthongization are to be expected; and formal conversation is the style in which similar patterns of behaviour either to that of reading style, or to that of careful style are to be predicted.

When describing Québec French long vowels in section 2.4.2, another effect of the length feature over the quality of vowels has been mentioned, namely the opening of the half-open vowels and the backing and rounding of the open back unrounded vowel.

Since, however, an extensive study of backing and rounding of long /a/ was given in section 2.2, there is no need to repeat here tables concerning this phenomenon. Nevertheless, backing and rounding of /a/ will be referred to when necessary, since it is closely related to the opening of the half-open segment /ɔ/ .

Thus, in order to complete the study of the long vocalic segments considered, a brief investigation of the opening of half-open segments will now be made.

2.4.4 Opening of half-open segments

2.4.4.1 Phonetic conditioning

/œ/ and /ɔ/, being [ɪlong] when followed by one of the lengthening consonants, i.e. /v(r), r, z, ʒ/ (1), were found to be diphthongized only when followed by /r/ (cf. section 2.4.3). In the remaining environments, these two vocalic segments were generally realized as more open and with less lip action than the cardinal vowels. In the consideration of the opening of /œ/ and /ɔ/ in this section, however, it is not the realization of these two vowels before /z, v(r), ʒ/ which is of interest, but rather another quality attributed to the vowel when in the presence of a final /r/. Very open varieties, described here as [ʌ:] and [ɔ:], were in fact found in this environment. Therefore, as for the study of diphthongization of /œ/ and /ɔ/, /r/ will be the only phonetic environment considered in the study of the opening of these two vocalic segments.

In the study of diphthongization, /ɛ/, long historically and when followed by /v(r), z, ʒ/, appeared to be the most frequently diphthongized vocalic segment, whereas its percentage of diphthongization when followed by /r/ was seen to approximate to that of all other vocalic elements. As in the case of /œ/ and /ɔ/, the front unrounded half-open segment /ɛ/ is generally realized as more open and less spread than the cardinal vowel when occurring in a lengthening consonantal context (2). When considering the quality of the

(1) cf. section 2.4.2 for the non-inclusion of /j/ in the lengthening consonants' group.

(2) cf. Gendron, (op.cit), section 2.4.2 p.181

vowel concerned here however, i.e. the opening of /ɛ/ towards a sound approaching to [æ], the reverse situation of that found for diphthongization occurs. Indeed, this realization of /ɛ/, as a very open segment, occurred only when followed by /r/. Only three instances of this realization were found in other environments in the speech samples. In careful style, one woman used this variety for the word neige, another one for fenêtre, and a third one for the word rêve. In all other cases, no occurrence of the very open variety affected long /ɛ/. Thus, /r/ will be the only phonetic environment relevant in examining the very open variety of /ɛ/, here described as [ɛ:] . The realization of the three half-open segments into very open varieties can be seen in the following vocalic trapezium.

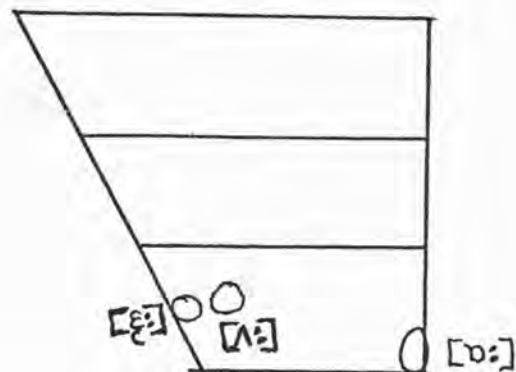

The phonetic conditioning of /r/ over all half-open vowels illustrates the tendency towards symmetry and the equalization of distances in phonological space. As seen for diphthongization, all long vowels were equally affected by this phenomenon. As for the opening of half-open vocalic elements, not only are they all liable to be realized as very open, but moreover this type of pronunciation is subject to only one phonetic conditioning, namely /r/. There is strong

empirical evidence given by these factors to the theoretical analysis set forth by Martinet in Economie des changements phonétiques, (1955). However, these questions of symmetry of phonemes and of linguistic change will be studied in more detail later.

At this stage in the investigation, it is worth noting that such a symmetry in phonological space exists. However, the phonetic realization of vowels involves more factors than simply pressures between phonemes. Social factors and pressures from the social environment in which individuals evolve are also important in accounting for changes or choices between various sets of pronunciation.

In order to investigate whether or not the opening of half-open vowels is subject to such social factors, these latter will be examined before any further conclusions are reached.

2.4.4.2 Age factor

Before analysing this sociological parameter, it must be noted that reading style will not be considered in the study of the opening of half-open segments. In this style in fact, no such phonetic values were attributed to the vowels studied. It is therefore only to be noted that no phonetic realizations, such as [ɛ: ʌ:] were elicited in this contextual style.

The first social factor to be examined is the age

factor, since a clear indication of a linguistic change emerged from its study. Table 20 gives proportional responses to [ɛ: ʌ: ɔ:] according to age. It is immediately apparent, when considering the results, that a linguistic change is in progress for the three half-open segments. The differences between the three age groups are generally very constant.

Age	/ɛ / +r → [ɛ:]		/œ / +r → [ʌ:]		/ɔ / +r → [ɔ:]	
	CS	FC	CS	FC	CS	FC
15-24	.310	.404	.209	.310	.520	.428
25-44	.259	.333	.100	.171	.430	.241
45+	.174	.292	.096	.118	.274	.236

Table 20: proportional responses to open segments by age, environment and style.

In all styles and for all three vocalic elements, younger informants always make the greatest use of the open varieties. They are followed by the middle-aged group who are followed by the oldest informants. The regularity offered by the age factor is striking. The following ordering always applies, i.e. 15-24 > 25-44 > 45+ . Although not being a direct cause for this change, it is nevertheless worth recalling that young speakers were also the ones using less diphthongized elements.

Another interesting aspect which emerges from this table is that of style shifting. All groups again display the same pattern of behaviour. The groups remain differentiated

to the same degree in all instances, and all of them show an increase in their use of [ɛ:] and [ʌ:] as they move to formal conversation.

For [ɔ:], however, all groups show rather a decrease in the incidence of this variety as they move to a less formal speech situation. These two different patterns of style shifting can be explained probably by the fact that people are usually more aware of forms which are involved in phonological contrast (1).

If /ɛ/ and /œ/ are first considered, there can be no such conflicting phonological forms to be observed. Indeed, both vowels are liable to become diphthongized, to be realized as much more open, etc.; but whatever the phonetic quality applied to these two vowels, they always remain distinct from each other and from any other phoneme. They in fact always stay on the same line of the trapezium, i.e. that they never change their front, unrounded, or rounded characteristics (cf. section 2.3.1.3). Therefore, it is not surprising to observe informants behaving as they do towards these two vowels: their use of an open variety decreases in a formal speech context, for this realization has probably not attained a high degree of consciousness. It is therefore normal to observe such a decrease. The linguistic change affecting these two long vocalic segments seems to progress chronologically, without yet being recognized as the norm for adoption in more formal speech situations.

On the other hand, the half-open back rounded segment is facing a different situation. An important factor is

(1) cf. P. Trudgill, (1974), p.103

that /ɔ/ may be involved in a phonological contrast with open back unrounded /ɑ/. As was seen in section 2.2 et seq., /ɑ/ may be realized as a half-open back rounded segment, i.e. [ɔ]. A semantic confusion may therefore occur between minimal pairs such as tard, tort, part, port, mare, mort, etc. This confusion created by the backing and rounding of /ɑ/ may affect lexical items in which /ɑ/ and /ɔ/ are followed by /r/. As Brent mentioned (cf. section 2.4.2), [ɑ:] frequently replaces long /ɔ/ before /r/, and concomitantly, /ɑ/ is backed when lengthened.

The overlapping of the two phonemes can be viewed in the following trapezium:

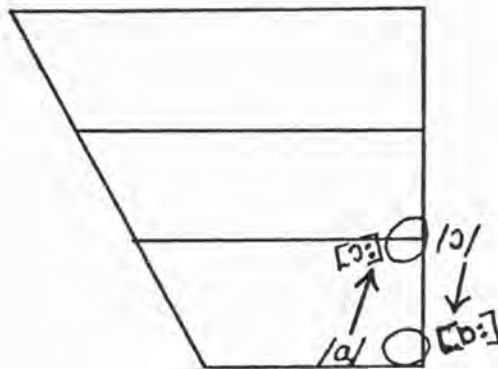

No special studies on minimal pairs involving these two phonemes have been carried out in this investigation. Thus, it cannot be said for certain that a use of [ɑ:] in part would lead to a use of [ɔ:] in port, i.e. /ɑ/ → [ɑ:] and /ɔ/ → [ɔ:], and conversely where usage of a back and rounded variety for part would automatically give a very open segment for port, i.e. /ɑ/ → [ɔ:] and /ɔ/ → [ɔ:], so that any semantic confusion would always be avoided. This is probably not the case at present and there might be many instances in which semantic confusion may occur.

Léon and Nemni carried out a study which attempted to evaluate the gap between the vocalic system of Standard French and that of Québec French, from the point of view of auditory perception. They recorded minimal pairs including the phonemic oppositions of the French vocalic system; these minimal pairs were produced by French Quebecers, but "decoded" by French listeners (1). In the phonemic opposition involving the phonemes /a/ and /ɔ/, they found that, in words like le bar, le bord, tard, tort, etc., the open back unrounded phoneme /a/ tended to disappear to the benefit of /ɔ/. On the other hand, not all of their three informants offered pronunciations which led to semantic confusions. For example, French listeners could most often perceive the phonological oppositions between /a/ and /ɔ/ when they were produced by speaker B. Even though Léon and Nemni do not draw very definite conclusions on this phonological opposition, it nevertheless appears that /a/ and /ɔ/ are sometimes distinguished and sometimes not when they are followed by /r/. Thus, it does not seem that there has been or that there is a complete merger of these two phonemes.

In addition, it has already been seen in section 2.2 that the open back unrounded phoneme /a/ can be realized as [a:] and as [ɔ:]. Even though the backing and rounding of /a/ has not been examined in the particular environment given by a following /r/, it nevertheless seems apparent that [a:] and [ɔ:] constitute possible surface realizations of the phoneme /a/ and that both sounds are part of the competence of the speakers.

Taking these factors into consideration, it can be assumed that there are many cases in which minimal pairs such

(1) R.Léon and M.Nemni, (1967).

as part and port will not be distinguished, but on the other hand, that there is a possibility that they will be. Thus, the following rule may be given:

Rule 1: /ɑ/ → ⟨[ɑ:-ɔ:]⟩ / -r †

Considering again table 20, it can be seen that the half-open back rounded phoneme /ɔ/ is involved in a linguistic change. In fact, when it is followed by /r/, it can be realized as a very open segment, namely [ɒ:]. This linguistic change is probably due to the effect of /r/, as it is the case for /ɛ/ and /œ/. However, table 20 indicates clearly that the very open variety [ɒ:] is in co-variation with the realization near the cardinal vowel value, i.e. [ɔ:], so that variability in the production of both sounds is present. Thus, the following rule may be given:

Rule 2: /ɔ/ → ⟨[ɔ:-ɒ:]⟩ / -r †

The linguistic change present in the half-open back rounded phoneme is, most probably, not only due to the effect of /r/ upon the vowel, but also to the fact that /ɑ/ and /ɔ/ may be involved in phonological contrast. The phonetic pressure exerted upon /ɔ/ by the backing and rounding of /ɑ/ is easily perceived by considering the behaviour of age groups, in the sense that, not only is [ɒ:] highly selected by all groups, but also that its percentage of occurrence increases in careful style. It was said above that people are usually more aware of forms involved in surface phonological contrast. This assumption is given empirical confirmation by the fact that all speakers are aware of the importance /ɑ/ and /ɔ/ have in the phonological system, by increasing their use of [ɒ:] in careful style.

This increase in usage of [v:] instead of [ɔ:] in careful style is also probably explained by a factor of hypercorrection. Hypercorrection is viewed here as the mechanism of change in response to pressures, such as the one created by the possible confusion between /a/ and /ɔ/ when they are followed by /r/. Pressures of this sort may lead to the need to find sets of norms and by doing so, it is not surprising to find speakers going beyond the goals at which they are aiming.

If use of the open variety [v:] were following the same pattern as those found for [ɛ:] and [ʌ:], a decrease in the incidence of [v:] should be present in careful style when compared with formal conversation. The increase of [v:] in careful style is thus probably due to the fact that speakers, consciously or not, are reacting to the pressure exerted by usage of [ɔ:] instead of [a:]. Another factor which should be noticed is that diphthongization of /a/ and /ɔ/ is very close in its phonetic realization, i.e. [aʷ:] for /a/ and [vʷ:] for /ɔ/. This factor may again explain a more extensive use of [v:] in careful style.

As has been seen up to now, /ɛ/, /œ/, and /ɔ/ are involved in linguistic change, as far as their open variety before /r/ is concerned. The symmetry between phonemes is preserved since all three half-open segments are affected in the same way by /r/.

However, they are not at the same stage of evolution. [ɛ:] and [v:] are in fact more often used than [ʌ:]. The gap in the incidence of these three varieties may be explained in the case of [v:] by a pressure between phonemes, which might itself lead to hypercorrection, whereas more usage of [ɛ:] will be dependent on other factors, as will be seen in the study of the remaining sociological parameters.

2.4.4.3 Education factor

Table 21 gives the proportional responses to [ɛ:], [ʌ:], and [ɔ:] by four educational groups. From this table, it can immediately be seen that the age factor again plays an important role. There are however two instances in which an educational difference is to be observed. In the case of [ɛ:], ed.1,2 are differentiated from ed.3 and 4 in formal conversation, and when considering [ʌ:], it is ed.3 which is differentiated from ed.1 .

	/ɛ/ +r→[ɛ:]		/œ/ +r→[ʌ:]		/ɔ/ +r→[ɔ:]	
	CS	FC	CS	FC	CS	FC
ed.1	.352	.500	.177	.333	.519	.423
ed.2	.210	.445	.087	.185	.362	.230
ed.3	.200	.100	.290	.450	.500	.450
ed.4	.222	.171	.128	.100	.312	.241

Table 21: Proportional responses to open segments by education, environment and style.

In the case of [ɛ:], there is not only an educational difference to be observed, but also a reverse pattern of style shifting. While ed.1 and 2 increase their use of an open [ɛ:] as they move to formal conversation, ed.3 and 4 show a decrease when placed in the same contextual style.

This different pattern of behaviour may be explained in terms of a linguistic change affecting this phoneme. Young, more educated informants give clear indications that this change is in progress.

Ed.2 follows about the same pattern as their younger counterparts, although realizing the open variety to a lesser degree. If a style shifting is to be observed for these two groups, it is probably because they are the leading groups in this change, but the change in progress has not risen to social awareness. Therefore, there is a decrease in usage of [ɛ:] when careful style is considered.

This indication of a linguistic change is confirmed by the behaviour of less educated informants, in that they display a reverse pattern of style shifting compared with that of more educated informants.

To explain this behaviour, the archaic pronunciation of /ɛ/ +r, i.e. [e:] must again be considered. In table 13, a sharp decrease in the use of [e:] was present when less educated speakers moved towards careful style. In section 2.3.3.1, it was noted that these speakers were very conscious of the negative social value attached to this pronunciation, and this awareness was demonstrated by an important style shifting. If the use of [e:] decreases in careful style, it could be asked which pronunciation less educated speakers would use to realize /ɛ/ +r. One of them can be the diphthong, as can be seen for young, less educated informants in table 17 (section 2.4.3.2). On the other hand, there is also the open variety [ɛ:] which they can select, and this they do, as can be observed in table 21. Even though using this variety less often in formal conversation, due to their high usage of [e:]

in this style, they show their awareness of a new form, here [ɛ:] , by using it more extensively in careful style. Their need to correct usage of [e:] in a more formal speech situation is ascertained by their awareness of a pronunciation undergoing linguistic change.

As was previously stated (cf. section 2.3.3.1.3), speakers are more aware of linguistic forms currently involved in linguistic change. This assertion is again confirmed by the behaviour of less educated speakers. The leaders of this change are the more educated informants, and especially the young ones. Following the social pressure exerted upon less educated speakers to correct a rejected form [e:], these latter show an awareness of the new form by increasing their use of it when moving into a careful speech situation.

The linguistic change in progress affecting long /ɛ/ fits Labov's model of a prestige feature undergoing linguistic change (1). In this model, young speakers of higher-ranking groups show the highest usage of the new form, here [ɛ:]. They are followed by older members of their group. In a lower-ranking group, older speakers are likely to use the new form more often than younger speakers. As can be seen for [ɛ:], this model applies very well, although differences between younger and older speakers are sometimes low.

Nevertheless, the situation offered by the open variety [ɛ:] proves that a linguistic change is not solely due to pressure between phonemes; it is also due to social pressures. In this case, it is certainly a result of the fact that the archaic pronunciation [e:] has been socially rejected and probably also because of a decrease in the incidence of diphthongization by younger speakers.

(1) W. Labov, (1966a), p. 327

Considering now [ʌ:] and [ɒ:], two different pictures emerge. To explain these different processes, the theory of Labov concerning "change from above" and "change from below" will be adopted (1).

The example of [ɛ:] illustrates the pressure of society upon language. In this case, rejection of the stigmatized linguistic feature [e:] leads to a pressure from higher-ranking speakers exerted upon lower-ranking members of the community which leads the latter to reject [e:] and to adopt a new form [ɛ:], especially in a careful speech context. This is what is referred to as "change from above" by Labov.

There is, however, another type of linguistic change involving a different social process. Labov describes this "change from below" as follows:

" We may describe this as change from below, because it is expressed as a gradual shift in the behaviour of successive generations, well below the level of conscious awareness of any speakers. In most cases, the shift begins with a particular group in the social structure and is gradually generalized in the speech of other groups. Usually the initiating group has low status in the social hierarchy - otherwise the change would be transformed into overt pressure from above" (2).

[ʌ:] probably offers the first stages of such a change, in which younger, less educated informants are the leaders. This explains the educational difference found between ed.3 and ed.1 .

However, [ɒ:] does not seem to be involved in either

(1) W.Labov, (1966a), pp.325-331

(2) Id., pp.328-29

change from above or change from below. In fact, young speakers together behave in the same way, as well as older speakers, independently of their educational background. At present, the new sound [ɹ:] seems to be represented in younger informants in general, without yet any implication of social stratification.

The patterns of style shifting found for [ʌ:] and [ɹ:] are the same as those found with the study of age groups. The explanation given in that section to account for different patterns of style shifting remains valid in this case.

The examination of the educational factor has provided further explanations for the linguistic change affecting /ɛ, œ, ɔ / + r. It has given further empirical evidence for the assumption that a linguistic change may depend on sociological factors.

2.4.4.4 Occupation and sex factors

The examination of these two sociological parameters offers more complex relationships, which can be seen in table 22.

When considering the patterns of behaviour towards [ʌ:], it may again be observed that this change is undergoing a process of change from below, i.e. below the level of social awareness. This vowel is not yet involved in occupational differences, but only in a linguistic change led mostly by young, less educated speakers. Although the differences are

		/ɛ / +r → [ɛ:]		/œ / +r → [ʌ:]		/ɔ / +r → [ɔ:]	
		CS	FC	CS	FC	CS	FC
P.	M	.266	.571	.100	.200	.287	.255
	F	.333	.580	.130	.307	.475	.384
WCW	M	.250	.343	.107	.138	.362	.214
	F	.175	.392	.115	.200	.462	.428
MW	M	.316	.255	.146	.200	.337	.250
	F	.108	.113	.177	.200	.425	.250

Table 22 : Proportional responses to open segments by occupation, sex, environment and style.

minimal, women show nevertheless slightly more awareness of this new form than their male counterparts, when careful style is considered. Moreover, it is women of the lowest-ranking status group who show a more frequent use of the new form [ʌ:] in careful style. This factor indicates the tendency of these women to be more aware of forms involved in linguistic change within their own social group. A similar case was observed in section 2.3.3.1.3 in which women showed less usage of stigmatized features than men, when these features were in a process of linguistic change within their social group. However, the differences either between occupational groups or sex groups are minimal and the above observations serve only to indicate tendencies of speakers, since the change affecting /œ/ is still at a very early stage.

When the open variety [ɒ:] is considered, it may again be observed that speakers react strongly to the pressure created by a possible confusion between /ɑ/ and /ɔ/. All of them display style shifting by increasing their use of the open variety [ɒ:] when moving to careful style. In this contextual style, no occupational differences are present, but there is on the other hand an interesting sex discrepancy. Independent of their occupation, men and women are in fact differentiated from each other to nearly the same degree. This sex differentiation observed in careful style indicates that women are more likely to be more aware of forms involved in surface phonological contrast than men.

In formal conversation, however, although the pattern remains very similar to that of careful style, a new distinction is being added. The differences now concern female professionals and white collar workers compared with the other groups. This is the only occupational difference present for [ɒ:]. However, the sex differentiation present is only altered by the fact that, in this contextual style, the pattern of behaviour of female manual workers is the same as that of men. Thus, in formal conversation, the two leading groups in the change affecting long /ɔ/ are female professionals and white collar workers. In careful style, all women are more aware than men of this phonetic realization, and therefore it may be said that women are more conscious than men of forms involved in linguistic change and in phonological contrast.

Where the open variety [ɛ:] is concerned, more complex relationships arise, as was found in the study of educational groups.

In formal conversation, there is an important occupational discrepancy with professionals being the leading group in the change. The following order of relationships applies for the use of [ɛ:] : professionals > white collar workers > male manual workers > female manual workers.

These relationships confirm the ones which were found between the two main educational groups. In formal conversation, there is indeed an important educational and occupational discrepancy. More educated speakers and professionals are the groups using the open variety [ɛ:] most frequently. This fact confirms the assumption that [ɛ:] is undergoing a process of linguistic "change from above". In this type of change, higher rates of usage of the new form are expected from higher-ranking speakers, and vice versa.

What is however very interesting to note is that this linguistic change has not reached a high degree of social awareness in higher-ranking status groups, since they show a decrease in the incidence of [ɛ:] in a more formal speech situation. However, very interesting relationships can be seen in this contextual style.

There is in fact no important occupational differences when men are considered, but male manual workers are those using [ɛ:] most frequently. The behaviour of this group of informants is not surprising, if their behaviour towards the archaic pronunciation [e:] is recalled. They in fact constitute the group using this archaic variety the most frequently. Thus, the different pattern of style shifting they display is not surprising either. What has been stated in section 2.4.4.3 applies in this case, in that the need of this group to correct usage of [e:] is seen in their decreasing use of this form in careful style, and moreover in

their awareness of the pronunciation undergoing linguistic change from above, i.e. [ɛ:].

On the other hand, there is an interesting occupational discrepancy between women and a sex discrepancy between males and females of the lowest-ranking status group. The first order of discrepancy is the one which is to be expected. [ɛ:] is undergoing a process of linguistic change from above, led by young, more educated speakers. In such change, it is not surprising to find that it is women of the highest-ranking occupational group who are more sensitive to this change.

In addition, female white collar workers show less awareness of the new form than female professionals, and slightly less than their male counterparts. This factor is probably explained by the fact that this change has originated in the highest occupational group and that it has not yet reached social consciousness.

The group which uses the open variety [ɛ:] the least frequently in careful style is that composed of female manual workers. Not only do they not display style shifting, but also they are segregated from other women and from their male counterparts in both contextual styles. They therefore seem to participate in this linguistic change only to a lesser degree.

A possible explanation for such behaviour may derive from the fact that [ɛ:] is involved in a change from above, in which professionals, and especially women, introduce [ɛ:] more widely. If the behaviour of female manual workers towards certain linguistic stereotypes is recalled (cf. section 2.3.3.1.3),

a similar pattern as that found for [ɛ:] can be observed. In fact, this group used the stigmatized features not involved in linguistic change within their own group more frequently than men, whereas they showed a different pattern of behaviour from that of their male counterparts when realizing stigmatized features involved in such a change. Thus, it was observed that women of this social group seemed more aware of social norms of speech, only when these were in a process of linguistic change within their own peer group, as is also the case for [ʌ:] and [ɔ:].

A similar case to that of archaic features not involved in linguistic change may be observed for [ɛ:]. In fact, this change affects mostly older speakers of the lowest-ranking groups, as was observed in section 2.4.4.3, even though differences between ed.3 and ed.4 were very low. Thus, women of the lowest-ranking status group do not react to this change from above, since they do not yet hear conflicting forms in younger speakers of their group. On the other hand, their lack of awareness of [ɛ:] might also be due to their lower use of the stigmatized feature [e:]. If table 13 is recalled, it can in fact be seen that women used this feature much less frequently than their male counterparts. Therefore, it is reasonable to conclude that female manual workers react less strongly to the pressure from above to correct too high a usage of [e:] than their male counterparts, since this feature is present to a much lower degree in their speech.

2.4.4.5 Conclusions

The first conclusion which can be drawn from the observation of social parameters is that the three half-open

vowels studied are involved in linguistic change. The observation of the age factor together with the educational parameter demonstrated that age was one of the most important factors accounting for different patterns of behaviour towards [ɛ:], [ʌ:], and [ɔ:].

The change affecting these long vocalic segments is subject to only one phonetic conditioning, namely /r/. This factor shows how symmetry between phonemes is kept, since their distinction is maintained by being equally affected by a phonetic realization implying opening, and this in the same phonetic environment.

Another factor which arises to give further empirical evidence for a theory of pressures between phonemes is the way speakers react to the open variety [ɔ:]. The increase of this variety in careful style observed in all groups of speakers probably comes from the pressure exerted by the possible confusion between such items as tard, tort, etc. Since long /a/ and long /ɔ/ may lose their phonological contrast because of the backing and rounding of the former vowel, speakers react, consciously or not, by aiming at a new set of norms. In doing so, their use of [ɔ:] increases in careful style. This reaction could lead to further confusions, since the realizations of /ɔ/ into [ɔ:] and /a/ into [a:] are phonetically very near. Nevertheless, this shows how such possible confusions between phonological forms may lead to a linguistic change.

The linguistic change involved in the opening of the half-open segments is, however, not solely due to pressures between phonemes. As has been previously observed, factors such as sex, education, and occupation contribute to the degree which a linguistic change reaches.

It was in fact found that [ɛ:] and [ʊ:] are more often used than [ʌ:]. A higher use of [ɛ:] in careful style, for example, depended largely on the social pressure exerted upon less educated speakers and mostly upon male manual workers to correct their use of a socially rejected form, namely [e:]. In addition, the change affecting this vowel was seen as a change from above; therefore professionals, and especially women, together with young, more educated informants were the leaders in this change.

In the case of [ʊ:], however, education and occupation did not play the same part. In fact, only one difference was found between occupational groups, in that women of higher-ranking groups were differentiated from women of a lower-ranking group. Apart from this difference, the two major factors involved in the change affecting this vowel were age and sex, whereby young speakers and women were seen as the leaders in this change. Even though no important educational and occupational differences were found for this vowel, as well as in the realization of [ʌ:], "change from below" may account for the linguistic change affecting these two vowels. In the case of [ʊ:] and [ɛ:], the change seems to be in fact below the level of consciousness. In addition, [ʌ:] is used the most frequently by younger, less educated speakers. As stated by Labov, a "change from below" shows gradual shifts from one generation to the other, is below the level of awareness, and has usually a lower status group as leader, i.e. here young, less educated informants (1).

To summarize the findings, the following variable rules can be given:

(1) W.Labov, (1966a), p.328

$$/ɛ/ \longrightarrow \langle [ɛ:] \rangle \quad / \quad -r \#$$
 f (style, age, education and occupation, sex)

$$/ɔ/ \longrightarrow \langle [ɔ:] \rangle \quad / \quad -r \#$$
 f (style, age, sex)

$$/œ/ \longrightarrow \langle [œ:] \rangle \quad / \quad -r \#$$
 f (style, age, education)

2.5 Conclusions on the vocalic variables

The preceding sections of this study dealt with the problem of accounting for variation in the speech of Trifluvians. In this study, many observations were made which reflected the awareness speakers have of the social significance of many of the variables studied. This awareness of a social significance attributed to some linguistic features was more or less acute depending on the variable involved and the speaker or group of speakers concerned. All of these factors contributed to variations in the speech of the informants interviewed. Far from being considered as irrelevant to a linguistic study, these variations have been conceived as an integral part of the structure of Trois-Rivières French, and moreover as the direct reflection of the social pressures and differences which exist among members of the Trifluvian community.

The variations in the speech of informants have been seen through the various phonetic realizations affecting the vowels studied. Table 23 gives an overall view of the phonetic vocalic realizations investigated in this study.

The various sounds capable of realizing one of the vocalic phonemes studied are combinatory variants of this phoneme. The various choices offered to a speaker to realize a given phoneme in a given phonetic environment are, however, dependent on the vocalic system itself, so that equalization between phonemes can be maintained.

PHONEME	ENVIRONMENT	VOWEL QUALITY
/ɛ/	1- Non-prominent syllable /ɛ +r +C / 2- Prominent syllable a) /ɛ/ → [+long] / $\left. \begin{array}{l} \text{lexically} \\ \text{determined} \\ \text{spelling: ai} \\ \text{ei, è, af, ef, ê} \\ \text{/v(r), z, ʒ/} \end{array} \right\}$ b) /ɛ/ → [+long] / -/r/	[ɛ] [æ] [ɛ:] [ɛ̃:] [e:] [ɛ̃:] [e:] [ɛ̃:] [e] [æ]
/ɑ/	1- Non-prominent position 2- Prominent position a) /ɑ/ → [+long] / $\left. \begin{array}{l} \text{lexically} \\ \text{determined} \\ \text{/v(r), r, z, ʒ/} \end{array} \right\}$ b) /wɑ/ → [+long] / -/r/	[ɑ̃] [ɔ̃] [ɑ:] [ɑ̃:] [ɔ:] [wɑ:] [wɛ:]
/ɔ/	1- Prominent position a) /ɔ/ → [+long] / -/v(r), z, ʒ / b) /ɔ/ → [+long] / - /r/	[ɔ̃:] [ɔ:] [ɔ̃:] [ɔ̃:]
/œ/	1- Prominent position a) /œ/ → [+long] / -/v(r), z, ʒ / b) /œ/ → [+long] / -/r/	[œ̃:] [œ:] [œ̃:] [ø:] [ʌ:]

Table 23: Phonetic realizations of /ɛ/, /ɑ/, /ɔ/, /œ/

The three half-open vowels /ɛ, œ, ɔ/ are contrasted by their front-back and rounded-unrounded features. None of the phonetic realizations of these three vowels involve changes in these features. Thus, the distinction between them is strongly maintained.

On the other hand, changes in the height position of the vowels may occur, so that these segments may become [+close], such as for /ɛ/ +r becoming [e:] and /œ/ +r becoming [œ:]. They may also be realized as more open, /ɛ/, /œ/, /ɔ/ thus becoming [ɛ:], [ʌ:], [ɔ:], respectively. Another possibility is to combine both these phenomena of opening and closing so as to give diphthongized segments, i.e. [ɛ^r:], [œ^v:], [ɔ^u:]. As these phonetic realizations show, all three half-open segments follow exactly the same pattern in that they are subject to the same types of phonetic phenomenon, namely the opening of the segments and their diphthongization, by means of opening the initial segment and moving to a closer element in the same vocalic area.

Moreover, the length feature has an important part to play in these realizations. In fact, these various realizations may only occur in a lengthening consonantal context.

The effect of length on these vowels may further be seen in its importance for the open unrounded phoneme /a/. As has been seen in section 2.2, length has a direct effect upon the quality of this vowel in that the longer it is, the more retracted its articulation is. Not only is this vowel realized as an open back unrounded vowel in some environments, but it may also undergo a process of backing and rounding to become realized as [ɔ] and it can also be diphthongized into [ɑ^u:].

All four long vocalic segments are liable to become diphthongized when in a lengthening consonantal context.

.The opening of half-open segments is subject to only one phonetic conditioning, namely /r/. For /ɛ/ and /œ/, the phonetic conditioning of /r/ might also be explained by a need to correct the socially rejected pronunciations [e:] and [œ:] which occur only in this environment. In order to correct these pronunciations, speakers may have to open these segments more than necessary. This opening may also be due to the effect of /r/ only.

For /ɔ/, /r/ is important in the opening of this segment not only in itself, but also because there may be phonological confusion between /a/ and /ɔ/, due to the backing and rounding of /a/ into [ɔ]. As was previously observed, minimal pairs such as part, port, mare, mort, etc., could be confused, the two phonemes losing their contrasting [+round], [-open] features. This phenomenon certainly exerts a strong pressure on /ɔ/ to be realized as [ɔ:].

The study of the four vocalic elements /ɛ, œ, ɔ, a/ has shown pressure within Trois-Rivières French phonological system. This pressure is expressed not only in terms of opening, closing, or backing. There is also an element of rounding, as seen in the case of /a/ becoming [ɔ], of lengthening, and of lip-spreading or lip-rounding, as in the case of /ɛ/, /œ/, and /ɔ/, which lose some of their lip-spreading or rounding properties by becoming more open.

As a result of the phonological realization, there is now a phonetic system of vowels consisting of many allophones, in which for example long half-open segments tend to

be pushed towards the bottom end of the vowel trapezium, and conversely the open back vowel is closed to a half-open position.

To illustrate this phonetic system of the vowels studied, phonetic rules will be given. The vowels will be taken as they occur in a lengthening consonantal context, since it is in this environment that most varieties occur and through which all vocalic segments may be compared better.

1- Realizations near cardinal vowel values

$$\begin{array}{l} / \varepsilon / \longrightarrow [\varepsilon:] \\ / a / \longrightarrow [a:] \end{array} / - \left\{ \begin{array}{l} \text{lexically determined} \\ \text{historically long} \end{array} \right\} C, \#$$

$$\begin{array}{l} / \varepsilon / \longrightarrow [\varepsilon:] \\ / a / \longrightarrow [a:] \\ / \text{œ} / \longrightarrow [\text{œ} :] \\ / \text{ɔ} / \longrightarrow [\text{ɔ} :] \end{array} / - / r, v(r), z, ʒ / \#$$

2- Diphthongization of the segments

$$\begin{array}{l} / \varepsilon / \longrightarrow [\varepsilon^{\text{r}}:] \\ / a / \longrightarrow [a^{\text{v}}:] \end{array} / - \left\{ \begin{array}{l} \text{lexically determined} \\ \text{historically long} \\ / r, v(r), z, ʒ / \end{array} \right\} C, \#$$

$$\begin{array}{l} / \text{œ} / \longrightarrow [\text{œ}^{\text{y}}:] \\ / \text{ɔ} / \longrightarrow [\text{ɔ}^{\text{v}}:] \end{array} / - / r / \#$$

3- Closing of the segments

$$/ a / \longrightarrow [\text{ɔ} :] / - \left\{ \begin{array}{l} \text{lexically determined} \\ / r, v(r), z, ʒ / \end{array} \right\} C, \#$$

/ɛ/	→	[e:]	/	-/r/ †
/œ/	→	[œ:]		
/wa/	→	[wɛ:]		

4- Opening of the segments

/ɛ/	→	[ɛ̃:]	/	-/r/ †
/œ/	→	[œ̃:]		
/ɔ/	→	[ɔ̃]		

All of these phonetic realizations are at present part of the phonetic vowel system of Trois-Rivières French, as realizations available to the speaker for a given phoneme in a specific environment. They are in co-variation with each other and the degree to which one variety is chosen instead of another strongly depends on stylistic and sociological factors. Through these two factors, as has been observed, a stylistic and social structure appears which explains in which way the various phonetic realizations are an integral part of a structure and not random variations. The social and stylistic structures will be further investigated in the synthesis of this work, but before doing so, the last variable, /r/, will be investigated.

2.6 Variable (r)

Québec French /r/ has two distinct allophones: a [+ant] alveolar flap [ɾ] or trill [r], and a [-ant] uvular flap or trill [R]. The [-ant] variety of /r/ may also be realized as a velar fricative, namely [ɣ]. The study of variable (r)-1 will deal with these two types of trill which are found in Trois-Rivières French. As was stated in section 2.1.5, the uvular trill is generally found in the region of Québec city, whereas the alveolar trill is mainly concentrated in the region of Montréal.

In Trois-Rivières, situated half-way between these two main cities, the two types of /r/ are used and the use of one or the other variety seems to depend mainly on the age and sex of the informant, as will be seen in the next sections.

The frequency of occurrence of these varieties will be examined in two main environments, i.e. when /r/ occurs in an initial and medial position, and when it is found in a final position.

In medial and final positions, /r/ is frequently in alternation with zero, i.e. [r] or [R] → ∅. The environments in which /r/ is likely to be deleted will be described in section 2.6.2.1 and the study of the co-variation of /r/ with zero will be referred to as variable (r)-2.

2.6.1 Variable (r)-1

As was seen above, there are three possible realizations

of the trill, namely [r], [R], and \emptyset . In the study of the co-variation of the alveolar and uvular trills, however, i.e. variable (r)-1, r-deletion is not taken into account when computation of proportional responses to one or the other trill is made. Therefore, only instances of r-pronunciation will be considered. This has been done in order to give the "absolute" relationship between the two trills. An example will illustrate this point.

Young, less educated speakers use the uvular trill [R] at a frequency of .800 when [R] occurs in an initial and medial position. In a final position, their use of [R] is as follows (when r-deletion is taken into account in the computation of results) : RS= .240 , CS= .280 , FC= .280 . These results mean that young, less educated informants use the uvular trill around 25% of the time. However, the results do not show whether these informants use the alveolar trill more frequently or not in this environment. They only show a decrease of nearly 60% in their use of the uvular variety compared with the other environment. To explain such behaviour, r-deletion must be considered, and from this, it appears that in fact young, less educated speakers delete /r/ over 70% of the time in a final position. The reduction in the incidence of the uvular trill by these speakers in a final position is therefore not owing to a higher usage of the alveolar variety, but to a high deletion percentage. In fact, this group of speakers never used the alveolar trill, but always the uvular trill when pronouncing an /r/ at the end of a word.

Thus, in order to compare these two trills better, r-deletion will not appear in the results and the values appearing in tables will reflect the proportional responses to [r] or [R]. For young, less educated speakers then, the

results when comparing both sounds will be as follows:
 initial and medial positions : [R] = .800 ; final position:
 [R] = 1.000 . Such results show the pattern of behaviour
 of groups towards one or the other variety more clearly, and
 will permit a more realistic study of the linguistic change
 affecting variable (r)-1.

2.6.1.1 The structure of variation of variable (r)-1

Some linguistic variables may serve to mark social or stylistic difference, as was seen in the case of most variables studied up to now. The differences found in the study of most variables were seen to indicate differences of degree rather than categorical differences. For some variables, speakers were clustered around a small range of values, as in the case of variable (a)-1 in formal conversation, whereas for others the distribution was much wider, as was observed for the use of archaic phonetic features.

Whatever the social and stylistic differences involved, however, variables generally presented cases of "inherent variability" , i.e. variables in which most of the speakers were participating in the choice of a variable with two alternatives (e.g. diphthongization, and further, variable (r)-2) (1) .

In the case of variable (r)-1 , however, a different structure of variation seems to emerge. This structure of variation does not seem to be "inherent", but is mainly due to linguistic change. According to Bickerton's theory (1971),

(1) cf. W.Labov,(1966a), and P.Trudgill,(1974).

variability is usually due to linguistic change in which speakers begin to switch from one categorical rule to another, i.e. in this case (1) /r/ → [r] and then (2) /r/ → [R]. This change from one categorical rule to another is reflected by the behaviour of speakers, in which a majority of them will approach a categorical application of either one rule or the other, and in which a minority will apply both rules optionally.

Bickerton suggests that variability in a speech community for a particular set of linguistic data is better explained in terms of linguistic change and :

"that a set of linguistic data which might seem to call as unequivocally as Labov's for variable rules, and which can indeed be accounted for in terms of such rules, can be better accounted for in terms of a series of changes in obligatory rules, each introduced by a period of optionality" (1).

Bickerton's statement is given empirical evidence from the particular set of data provided by the change from an alveolar [r] to the uvular [R]. The behaviour of individual speakers will be given here in order to illustrate this point of view. The speakers mentioned for the use of [r] and [R] applied either one rule or the other categorically for all phonetic environments and all contextual styles.

1- categorical use of the alveolar trill [r]

	<u>Total</u>
a- <u>Male professionals:</u>	
M.1.4 - M.1.5- M.1.8- M.1.9- M.1.10	5

(1) D.Bickerton, (1971), p.458

b- <u>Male white collar workers</u>	
M.2.3- M.2.6 - M.2.7 - M.2.8 - M.2.9 - M.2.10	6
c- <u>Male manual workers</u>	
M.3.1 - M.3.4 - M.3.6 - M.3.7 - M.3.8 - M.3.9- M.3.10	7
	<hr/>
	18
d- <u>Female professionals</u>	
F.1.4 - F.1.7 - F.1.8 - F.1.9	4
e- <u>Female white collar workers</u>	
F.2.6 - F.2.7 - F.2.8	3
f- <u>Female manual workers</u>	
F.3.8- F.3.9 - F.3.10	3
	<hr/>
	10

2- Categorical use of the uvular trill [R].

	<u>Total</u>
a- <u>Male professionals</u>	
M.1.2 - M.1.3 - M.1.6	3
b- <u>Male white collar workers</u>	
M.2.1 - M.2.2 - M.2.4	3
c- <u>Male manual workers</u>	
M.3.2 - M.3.3	2
	<hr/>
	8
d- <u>Female professionals</u>	
F.1.1 - F.1.2 - F.1.3 - F.1.5 - F.1.6 - F.1.10	6
e- <u>Female white collar workers</u>	
F.2.1 - F.2.3 - F.2.4 - F.2.5	4
f- <u>Female manual workers</u>	
F.3.1 - F.3.2 - F.3.3 - F.3.4 - F.3.5 - F.3.6	6
	<hr/>
	16

3- Optional use of the uvular trill [R] .

Eight speakers out of the total number of sixty displayed variable behaviour towards variable (r)-1. To provide a detailed description of the patterns of behaviour of these speakers, their proportional responses to [R] by environment and style will be given.

	<u>Initial and medial positions</u>			<u>Final position</u>		
	RS	CS	FC	RS	CS	FC
a- Male professionals						
M.1.1	1.000	1.000	.200	1.000	1.000	.200
M.1.7	.000	.400	.500	.000	.400	.000
b- Male white collar worker						
M.2.5	.107	.365	.200	.000	.875	.000
c- Male manual worker						
M.3.5	.000	.200	.000	.000	.500	.000
e- Female white collar workers						
F.2.2	.200	.903	.400	.000	.857	.100
F.2.9	.255	.000	.100	.000	.000	.000
F.2.10	.333	.500	.000	.250	.342	.000
f- Female manual worker						
F.3.7	.000	.269	.020	.000	.416	.000

Table 24: Use of [r] and [R] for sixty informants by environment and style.

As the detailed data given above illustrate, Bickerton's theory applies in the case of variable (r)-1. The application of obligatory rules by a majority of 52 informants is as follows:

- 28 informants apply the following rule categorically:

$$/r/ \longrightarrow [r]$$

- 24 informants apply the following rule categorically:

$$/r/ \longrightarrow [R]$$

- The remaining 8 informants apply both rules optionally:

$$/r/ \longrightarrow \langle [r, R] \rangle$$

The variable behaviour of the eight informants counters, however, Bickerton's theory stating that the optionality applying in the realization of a rule can affect only one environment at a time. If careful style is considered, six informants display variable behaviour in all phonetic environments. For these speakers, variation in the use of [r] or [R] is "inherent" since they participate in the choice of both alternatives depending on the contextual style.

The well-known concept of "inherent variability" developed by Labov and criticized by Bickerton seems to find both its application and non-application here. Labov's and Bickerton's theories seem to be applicable, but the degree to which one or the other theory applies seems to depend largely on the stage each phonetic variable has reached in the social and linguistic processes.

In the use of diphthongization, for example, it was seen that a majority of speakers participated in the choice of a monophthong and a diphthong in realizing a long vocalic element. Both realizations of a long vocalic segment were represented in the speech of each individual and this has therefore proved to be a case of "inherent variability". In the case of /r/, the variation is inherent for

at least eight speakers, whereas it is not for the remaining 52 informants. This is due to the type of linguistic variable involved. Diphthongization, as well as variable (a)-l, presented cases where use of a diphthong and of a back and rounded variety had historical origins and were due to a phonetic conditioning, namely the length of the vowel. There were moreover no clear-cut indications of a linguistic change in progress, although small age differences were found. These two types of linguistic variables appear to have been maintained over long periods of time as a stable system of alternatives, which therefore led to variability and served to mark social and stylistic differences, and still do.

The case of variable (r)-l is, however, somewhat different. Use of an alveolar or uvular trill also has a historical origin, but as was previously stated (cf. section 2.6) , serves to mark regional rather than social differences. Moreover, use of one or the other variety does not seem to be dependent on phonetic conditioning but rather on regional custom.

Trois-Rivières is generally represented as an area where the alveolar trill [r] is used. This fact was emphasized by 5 informants who viewed Trois-Rivières French as linguistically different from other areas such as Québec city, because of Trois-Rivières French "rolled" /r/. Even informants using the uvular variety categorically had the same feeling. This categorization of Trois-Rivières French as an alveolar trill representative is not surprising if the behaviour of groups is considered. As was stated at the beginning of this section, use of the alveolar [r] is undergoing rapid linguistic change, as can be observed in the following age distribution.

		15-24	25-44	45+
/r/ → [R]	RS	.846	.504	.072
Initial and medial positions	CS	.884	.526	.092
	FC	.800	.512	.068
/r/ → [R]	RS	.897	.560	.069
Final position	CS	.954	.600	.117
	FC	.828	.596	.062

Table 25: Proportional responses to [R] by environment, age and style.

The linguistic change affecting the use of an alveolar [r] is clearly indicated in this table. The older group is almost untouched by the change, the middle-aged one hovers around the 50-50 mark, and finally the younger group has a behaviour pattern exactly opposite to that of the older group by using the new form [R] almost exclusively. The linguistic change is moreover not at all involved in stylistic variation, all groups behaving in the same way towards [R] whatever the contextual style involved. In addition, the groups of speakers concerned here have the same pattern of behaviour towards [R] whatever its place in the word. There is thus no phonetic conditioning nor stylistic conditioning affecting the use of an alveolar or uvular trill. The study of age groups seems to illustrate a change through "random drift". In such a change, there is a uniform change from one age level to another, without any stylistic or class differences involved (1).

The structure of variation offered by the examination

(1) cf. W.Labov, (1966a), p.324

of age groups is further illustrated by the comparison of four educational groups.

		ed.1	ed.2	ed.3	ed.4
/r/ → [R]	RS	.861	.269	.800	.225
Initial and medial positions	CS	.916	.292	.800	.246
	FC	.800	.271	.800	.230
/r/ → [R]	RS	.887	.271	1.000	.300
Final position	CS	.946	.308	1.000	.286
	FC	.804	.279	1.000	.272

Table 26: Proportional responses to [R] by environment, education and style.

As can be observed in this table, variable (r)-1 is not involved in either stylistic or educational variations. Speakers behave consistently towards the uvular variety in all contextual styles and phonetic environments.

The interesting discrepancy present in table 26 is to be seen through the age factor. Indeed, young speakers are clearly differentiated from their older counterparts, independent of their educational background. Therefore, age seems to be the important parameter in accounting for variations within the sample.

In table 24, the pattern of behaviour of individual speakers was presented and, through it, it could be seen that a majority of speakers applied the rules (1) /r/ → [r̄] and (2) /r/ → [R] categorically with only a minority showing

optionality in the realization of both rules. The categorical application of one rule or the other showed that there was no "inherent variability" present in the speech of most informants for variable (r)-1. On the other hand, the optional selection of [r] and [R] by eight speakers demonstrated that the concept of "inherent variability" applied in their case. Averaging out group scores for age (table 25) and education (table 26) does not alter this fact. These group scores are indeed an accurate reflection of the linguistic competence of individuals and they serve to indicate the linguistic change affecting variable (r)-1.

When a linguistic change is taking place, however, the age distribution is often complicated by the fact that the change may follow more complex patterns. It may originate in a particular sub-group of the community and thereafter spread to other groups (cf. section 2.2.7 and section 2.4.4.4). If table 24 is considered, an important sex discrepancy emerges. In the second part of the table, where speakers using the uvular variety [R] categorically are presented, it can be observed that 16 women used the new variety [R] as opposed to 8 men. This pattern of behaviour by women is not surprising since it was seen for other variables, e.g. open varieties [A:] and [v:], that women are more aware than men of a linguistic change in progress.

In addition, there are two occupational differences to be observed. The first one concerns male manual workers who participate to a lesser degree in the change, and the second one shows less female white collar workers using the uvular variety than other women. However, these two occupational differences are minimal and the significant parameters to account for variability within the sample are clearly age and sex.

2.6.1.2 Summary

The kind of distribution offered by the study of variable (r)-1 is probably one of the simplest which can be found in a linguistic study. This variable has in fact no social significance, i.e. has not been stigmatized nor yet awarded prestige, and is not involved in stylistic variation. A gradual linguistic change is indicated in the uniform change from one age level to another. This change is further represented by the behaviour of women who use the uvular variety more frequently than men. Age and sex are therefore the only social parameters to be retained in the explanation of variability found within the sample and they can be summarized in the following variable rule:

$$\begin{array}{c} /r/ \longrightarrow \langle [r, R] \rangle \\ f(\text{age, sex}) \end{array}$$

The structure of variation of variable (r)-1 is accounted for in terms of both Bickerton's theory and Labov's variable rules. Following Bickerton's point of view, variability due to linguistic change is expressed through the behaviour of individual speakers. The majority of them apply one rule or the other categorically, i.e.

- 1- 28 informants apply /r/ \longrightarrow [r] categorically
 - 2- 24 informants apply /r/ \longrightarrow [R] categorically
- with only a minority of speakers applying both rules optionally.

Where Labov's variable rules come into play is when variable behaviour is present. Variability is in fact "inherent" in the 8 speakers displaying such behaviour, since they use [r] and [R] in the two phonetic environments, and this in the same contextual style (e.g. careful style).

Bickerton's theory applies in the case of variable (r)-1 since this variable is probably the simplest case of variability which can be found. From a similar use of the trill as that of the region of Montréal, Trois-Rivières seems to have moved towards the variety used in the area of Québec city. This change is probably partly due to the influence of radio and television, since most speakers of these mass media are heard to use the uvular variety whatever their place of origin and this fact has probably had an influence on the speech of young people.

Nevertheless, the linguistic change present in variable (r)-1 is of the simplest kind. It is not involved in stylistic and social variations. It is only a gradual change from one generation to another, which is mostly represented in the speech of young informants and women. This is probably why Bickerton's theory applies so well in this case. As will be seen in the next section, however, Bickerton's theory no longer applies when a more complex variable is considered. Indeed, as for variable (a)-1, diphthongization, etc., variable (r)-2 is involved in social and stylistic variations and in such cases most speakers display variable behaviour. However, before reaching more definite conclusions on these points, variable (r)-2 will be studied.

2.6.2 Variable (r)-2

The two Québec French liquids /l/ and /r/ are in frequent alternation with zero. In general, both are regularly deleted after word-final stop and word-final labiodental fricative; /r/ is also occasionally deleted before word-internal stop, word-internal [+ant] fricatives and before /l/, and finally /l/ is also sometimes intervocalically deleted (1).

This section will deal particularly with r-deletion as it occurs in five main environments. The computation of the results occurring in tables will take account of all r-pronunciation v. all r-deletion, i.e. [r] and [R] → ∅, since usage of one or the other variety of the trill had no direct phonetic effect on r-deletion.

2.6.2.1 Phonetic conditioning and historical perspective

A) Phonetic conditioning

There are various phonetic environments in which /r/ cannot be deleted. These are:

- 1- In an initial position, i.e. never #/r/-
e.g. rouge, rapide, renard; etc.
- 2- When /r/ occurs between two vowels, i.e. never -V/r/V-
e.g. carême, garage, etc.

(1) Cf. G.Sankoff and H.Cedergren, (1971) and E.Brent, (1971).

- 3- After word final vocalism, but when followed by a word beginning with a vowel, i.e. never $-V/r/\# \#V-$
 e.g. pour avoir..., mon père allait, etc.
- 4- When /r/ follows a consonant and is itself followed by a vowel or by the glide /ɥ/, i.e. never $C/r/V$ and $C/r/ɥ$
 e.g. bracelet, fromage, bruit, fruit, etc.

However, the phonetic environments in which /r/ can be deleted are also numerous. It can be deleted in the following environments:

- 1- When /r/ follows a consonant and is itself followed by the glide /w/, i.e. $/r/ \rightarrow \emptyset / - C(r)w$
 e.g. trois, croix, étroit, etc.
- 2- Before word-internal and word-final stop and [+ant] fricative, i.e. $/r/ \rightarrow \emptyset / -V (r)C (\#)$
 e.g. mercredi, aujourd'hui, mars, parle, parce que, etc.
- 3- After word-final stop and word-final labio-dental fricatives in a pre-pausal position, i.e. $/r/ \rightarrow \emptyset / -C(r)\#$
 e.g. peut-être, notre, autre, arbre, vivre, comprendre, etc.
- It should be noted that in words like notre, votre, peut-être, etc., /r/ is often deleted even if the following word begins with a vowel, i.e. $/r/ \rightarrow \emptyset / - C(r)\# \#V$
- 4- After word-final vocalism in a pre-pausal position, i.e. $/r/ \rightarrow \emptyset / - V(r)\#$
 e.g. part, rire, jour, peur, hiver, corps, etc.

- 5- After word-final vocalism, but followed by a word beginning with a consonant, i.e. /r/ → ∅ / - V(r) † † C-
 e.g. manière de..., pour chasser....., avoir des..., sur la...
 etc.

This last case might have been considered together with environment 2, i.e. -V(r)C (†) , since it represents the same type of environment. However, the environment -V(r) † † C- is much more favourable to r-deletion than the environment -V(r)C (†) , as will be shown later in tables. In the former environment, the relevant feature will therefore be the initial segment of the succeeding word.

B) Historical perspective

Environment -C(r)w

The Map 1333 trois of the ALF reveals that r-deletion applied frequently in this phonetic environment, and shows that it was mainly found in the North area of Loire.

This is the only environment in which r-deletion, after a consonant, can be traced historically. In the speech samples studied, r-deletion occurred only in this environment, whereas it never did in any other -C(r)- group. The glide /w/ is therefore certainly important in accounting for the disappearance of /r/ in the group C(r)w.

Environment -V(r)C (†)

The disappearance of /r/ before a consonant finds its origin in the 12th century, and was maintained until the

17th century. An influence of popular speech as well as dialectal influence can be traced in the tendency of deleting /r/ before a consonant. The Maps of the ALF reveal that r-deletion existed up to the 19th century, especially in Normandie. The Maps 712 jardin, 839 mercredi, etc., account for this phenomenon. In addition, Juneau's study shows that r-deletion before a consonant has been preserved in Québec French.

e.g. mercredi: "Mecredy" Archives de la Province de Québec, Sanguinet, 3 juillet 1770, Québec.
parce que: "...pasce que ausitot que le dit Parant fut antré dant la salle..." Archives de l'Archevêché de Québec, l'Ancienne-Lorette 1, 21, 24 août 1793 (1).

In Trois-Rivières French, /r/ is still deleted in this environment, but at a low level as will be seen in the tables.

Environment -C(r)#.

The historical origins of r-deletion after a consonant can be seen in the popular Parisian speech of the 17th century as well as in those of the areas of Northern France.

Juneau found many examples of r-deletion in Archives.
 e.g. peut-être "petâite jamais" Archives de l'Archevêché de Québec, l'Ancienne-Lorette, 1,19,1793.

notre: "not..." Id., 1,21, 14 août 1793.

prendre: "tisane sudorifique pour prande en cinq prise" Archives de la Province de Québec, Petites collections, Hamel, 1792, Québec (2).

(1) M. Juneau, (1972), pp.163-64

(2) Id., pp.205-06

The disappearance of the final /r/ preceded by a consonant is still widely spread in Trois-Rivières French, as will be seen in the tables.

Environment -V(r)†

In a final position, no /r/ was pronounced in French from the 13th century up to the 17th century. Deletion of a final /r/ preceded by a vowel has therefore also been introduced in Québec French.

-oir : In this environment, r-deletion has its origin in popular Parisian French as well as in the speech of the North-Western, Western regions and those of the Centre. According to Juneau, "... ce trait d'allure rustique est solidement ancré au Québec dans le peuple et seuls les milieux cultivés l'ont éliminé de façon à peu près systématique" (1). This feature has been strongly implanted in Québec French, since the majority of Parisians and Provincials deleted /r/ until the 18th century.

-eur : r-deletion in this environment was maintained until the 18th century in general French and even until the end of the 19th century in the dialects of Northern France. This pronunciation without /r/ is still frequent in present day Trois-Rivières French.

-er (-ère, -aire, etc.): According to Juneau, r-realization in Québec French has been reintroduced quite early in this environment (2). The ALF Maps 468 entière, 1159 rivière, etc., demonstrate that r-deletion was mostly concentrated in Normandie and in the area of the Centre.

(1) M. Juneau, (1972), p.168

(2) Id., p.169

From the results of the present investigation, however, it will be seen that speakers still delete /r/ as often with the ending -er as with the ending -eur and -oir.

r-deletion has also affected endings in -ir and in -ur .

e.g. sentir : "ne veule pus voir le dit curé ni le sentis..."
Archives de l'Archevêché de Québec, l'Ancienne-Lorette,
1, 19, 1793 (1).

sur: "su le qué" Archives de la Province de Québec,
Petites Collections, Galarneau,L., 1830, Cap-Santé (2).

In general, r-deletion in Québec French has its origin in the popular speech of l'Île-de-France of the 17th and 18th centuries, and also in the speech of the North-Western and Western provinces as well as those of the Centre.

From Juneau's investigation, it seems that r-deletion after a vowel would have mainly affected nouns ending in -oir and in -eur. From the results of the present study, however, /r/ appears to be deleted generally to the same degree after any vowel. To illustrate this fact, a table showing proportional responses to r-deletion by three occupational groups will be given. In this table, five environments have been considered. They are: -oir, as in mouchoir, avoir, etc., -eur, as in beurre, leur, etc., -ère,-aire,-erre, etc., as in soustraire, verre, etc., -er, as in hiver, hier, etc., and -or, as in corps, mort, etc.

Table 27 shows very clearly that there is no significant discrepancy between these five phonetic environments. If formal conversation is considered, professionals delete /r/

(1) M.Juneau,(1972), p.165

(2) Id., p.169

		Professionals	White collar workers	Manual workers
-oir	CS	.133	.191	.383
	FC	.222	.200	.666
-eur	CS	.142	.188	.557
	FC	.192	.295	.558
-ère, etc.	CS	.083	.211	.494
	FC	.234	.269	.586
-er	CS	.116	.366	.550
	FC	.200	.307	.428
-or	CS	.068	.187	.418
	FC	.173	.296	.343

Table 27: Proportional responses to r-deletion by 5 vocalic environments, occupation and style.

between 17% and 23% of the time, white collar workers between 20% and 30% of the time, and finally manual workers omit /r/ after any vowel between 34% and 66% of the time. Although some differences can be seen, it remains evident that the discrepancy between the phonetic environments is usually at a low level and therefore not sufficient to justify a study of r-deletion taking account of various vocalic environments. Another interesting aspect is that presence or absence of an underlying schwa /ə/ does not seem to affect r-deletion. There is in fact no significant discrepancy in r-deletion between the environments -ère, etc., and -er. Thus, the rule which allows r-deletion, when /r/ occurs finally after a vowel,

operates regularly independently of the phonetic characteristics of the preceding vowel and independently of whether or not /r/ is followed by an underlying schwa. For these reasons, the study of r-deletion will be made generally in this environment, i.e. /r/ → ∅ after any vowel: -V(r)‡.

As has been seen up to now, r-deletion is not an innovation of Québec French, but rather a phenomenon having historical origins.

Phonetically, r-deletion, or at least weakening in the production of /r/, may be due to over-shortening of this liquid according to Gendron. As he states:

"Les voyelles canadiennes sont généralement plus longues que les voyelles françaises, tandis que les consonnes canadiennes sont toujours, sans exception, sensiblement plus brèves, non seulement dans la position intervocalique inaccentuée, mais aussi dans la même position accentuée, ainsi qu'en finale" (1).

He adds further:

"...leur tenue consonantique trop brève les empêche de se réaliser avec autant de plénitude qu'en français normal. Rien d'étonnant dès lors qu'elles aient tendance à disparaître dans des mots-outils à l'intérieur de groupes syntaxiques (sur la > su a), dans des groupes complexes (r et l dans trois, ployer), ou encore en position implosive (l en particulier, par ex. dans résultat) ou en finale (t dans communiste)" (2).

The deletion of /r/ in various phonetic environments could be due, as Gendron states, to the length of the consonant. If, as Gendron mentions, length is a function of the articulatory energy needed in the production of a

(1) J.D.Gendron, (1966), p.137

(2) Id., p.138

consonant, then reduction in this feature could lead to a weakening in the articulation of /r/ and thereafter to its disappearance.

Deletion of /r/ could also be due to general tendencies which arise from purely articulatory causes. In the environments -C(r)w-, -V(r)C (#), -V(r)# #C-, C(r)#, r-deletion could be attributed to a tendency to reduce consonant clusters, i.e. to aim at cluster-simplification (1), despite the fact that this can create homophones between pairs such as droit,doit, trois,toi, etc. These are merely possible explanations to account for r-deletion in general Québec French.

In Trois-Rivières French, or at least in the speech sample studied, r-deletion occurs in all five environments mentioned above. However, r-deletion is never maintained at a 100% level nor is it always absent, i.e. \emptyset stays in constant co-alternation with /r/. Realizing /r/ or deleting it constitute two choices offered to a speaker, both having been in co-alternation over a long period of time, as indicated in the historical notes, and both possibilities remaining available in present day Trois-Rivières French.

This choice between /r/ and \emptyset leads to optionality in the realization of one rule or the other, which itself leads to variation in the speech of individuals. The structure of variation of variable (r)-2 will now be examined.

2.6.2.2 r-deletion: a case of "inherent variability".

Bickerton (1971) has interpreted variability in a

(1) cf. A.C.Gimson,(1970), and D.Bickerton,(1971),etc.

particular rule as a process solely due to linguistic change. Although he admits variability, he tries to eliminate it as much as possible by referring it to the linguistic change affecting a rule in which, for any particular speaker, variability can only exist in one environment at a time, and where, after a rule has become categorical for a speaker in one environment, it can begin to be optionally applied in another environment, etc. Thus, although Bickerton admits variability, he does not believe in variable rules and "inherent variability", in which speakers are seen to be able to operate by means of optional rules.

Bickerton's point of view can probably best apply in very simple cases, where a variable undergoes simple linguistic change, without any social and stylistic variation, as was the case for variable (r)-1.

There are however different kinds of variables which exist and in the light of evidence given by Labov (1966a), there is no doubt that human beings can process and deal with variation and optionality. The example of variable (r)-2 is available to verify this assumption.

The data provided by the behaviour of individual speakers show that 54 speakers display variation in more than one environment at a time towards variable (r)-2. Mostly in the environments $-V(r)C$, $-V(r)\# \#C$, $-V(r)\#$, these speakers show both presence and absence of r-deletion. /r/ and \emptyset are therefore in co-variation for a majority of 54 informants, and this in two, three or more phonetic environments.

These speakers show their ability to behave in terms of variation by displaying optional application of the rule $/r/ \rightarrow \emptyset$. The observation of patterns of behaviour of

individual speakers provide the following evidence:

1- there are no speakers who never delete /r/; nor are there any who always preserve r-deletion. A majority of speakers show variation in the rule /r/ → ∅ in more than one environment at a time. It is therefore a case of "inherent variability";

2- for every speaker and every group, the same phonological constraints operate: a) there is a categorical non-deletion of /r/ in the environments #/r/- , -V/r/V-, -V/r/# #V- , C/r/V-, and C/r/ɥ . Therefore, for every informant, the presence of an adjacent vowel operates as a categorical constraint not to delete /r/; b) the presence of a consonant following /r/ and /r/ being in a final position are both environments favouring r-deletion, although not categorically.

These facts show that /r/, in the cluster -(r)C and in a final position, is present in the underlying form mercredi, faire dire, trois, quatre, noir, and that a variable rule deletes it.

In the rule /r/ → <[r, R] - ∅>, the output of the rule is variably selected from two discrete alternatives. Choice between these two alternatives is made optionally and therefore leads to "inherent variability".

As mentioned in section 2.6.1.1, Bickerton suggests that variability is never really "inherent". When variation is present, it is rather due to linguistic change which is affected in such a way that, at any given point, a majority of speakers approach 100 percent application of either one rule or the other, with only a minority hovering around the 50-50 mark. The patterns of behaviour of individual speakers

given above showed that Bickerton's assumption does not apply in this case, since a majority of 54 informants display variable behaviour in more than one phonetic environment, and moreover since none of the informants showed categorical selection of either /r/ or \emptyset .

Another factor which tends to verify the fact that variable (r)-2 is in fact inherent is that there is no sign whatsoever of any linguistic change taking place. If the Trifluvian informants are divided into three age groups, the figures for r-deletion are obtained in table 28.

/r/ → \emptyset		15-24	25-44	45+
-V(r)C	RS	.097	.090	.088
	CS	.035	.047	.060
	FC	.131	.218	.187
C(r)w	CS	.055	.037	.055
	FC	.300	.642	.306
-V(r)‡	RS	.317	.237	.205
	CS	.434	.396	.296
	FC	.355	.389	.325
-V(r)‡C-	RS	.301	.325	.291
	FC	.414	.440	.395
-C(r)‡	RS	.236	.263	.229
	CS	.208	.229	.229
	FC	.700	.805	.790

Table 28: Proportional responses to r-deletion by environment, age and style.

Thus, groups of speakers of whatever age use approximately *r*-deletion to the same degree according to the phonetic environment concerned. Not only is there no age discrepancy present, but there are also similar patterns of behaviour in respect of style shifting and phonetic environment.

All groups of speakers are seen to increase *r*-deletion as they move from careful styles to formal conversation. In addition, with the exception of the middle-aged group towards *r*-deletion in the environment $C(r)w$, all groups delete /*r*/ the least often in the environment $-V(r)C$ ($\#$), with thereafter a fairly regular increase in their *r*-deletion percentage up to the last environment, i.e. $-C(r)\#$, at which the highest rate of *r*-deletion is found.

What is also interesting to note is that the most important style shifting present in all age groups is to be observed when /*r*/ follows a consonant, i.e. $C(r)w$ and $-C(r)\#$, whereas the degree of style shifting is far less important when /*r*/ is in the neighbourhood of a vowel, i.e. $-V(r)C$, $-V(r)\#$, $V(r)\#$ $\#C$.

The regularity of the structure given by the comparison of age groups supports the assumption that variable (r)-2 is a case of "inherent variability". There is indeed no linguistic change affecting *r*-deletion in any phonetic environments, and moreover all age groups have the same stylistic pattern of behaviour and show similar percentage of *r*-deletion according to specific phonetic environments.

Thus far, variable (r)-2 has been seen as a case where there is variation in the application of the rule $/r/ \rightarrow \emptyset$.

Most speakers were seen to participate in the process of variability, which itself operates without indications of a linguistic change. In the light of the above historical notes, it can be seen that r-deletion is not a new linguistic phenomenon, but that the linguistic variable represented by the co-variation of /r/ and \emptyset in five main phonetic environments appears to represent a stable system of alternatives which has been maintained for a long period of time.

Such a variable may serve to mark social and stylistic differences. A first indication of stylistic variation has been observed with the comparison of age groups. The observation of educational, occupational, and sex parameters will now serve to clarify the type of social process in which this variable is involved.

2.6.2.3 Differentiation by education

The results of table 28 demonstrated that no linguistic change is at present affecting use of r-deletion within the sample. In addition, the only interesting difference found between four educational groups, which also takes account of age as a factor, only concerned the difference between the two main educational groups. It was therefore felt inappropriate to use this type of grouping in the study of the educational parameter. Instead, three groups will be concerned here since interesting discrepancies emerged between informants who have had 13 or more years of education, those who have had between 10 and 12 years of schooling and those who attended school for 9 years or fewer.

Figures 16 to 20 inclusive illustrate the patterns of behaviour of these three educational groups towards r-deletion by five phonetic environments.

It is immediately apparent that the three educational groups are segregated from each other for all five phonetic environments. The most educated informants always use r-deletion the least often in all contextual styles and for all phonetic environments. Usually, they are followed by the informants who have had between 10 and 12 years of schooling, and finally the least educated speakers follow with the highest percentages of r-deletion.

There are two exceptions in the ordering 13+ < 10-12 < 9- , and these involve r-deletion occurring in the environments -V(r)C and C(r)w . In both cases, the informants who have had between 10 and 12 years attendance at school deviate from the regular structure by approaching the pattern of behaviour of more educated informants in formal speech styles, and by approaching and even exceeding that of less educated speakers in formal conversation.

Factors which can account for such deviations lie in the nature of distributions in which, for some variables, speakers are clustered around a small range of values, as for diphthongization of some vocalic elements, and for others, the distribution is more spread, as was the case for archaic phonetic features. This nature of distributions may also apply in respect to particular environments for a single rule. In one environment, speakers may be clustered around a relatively small range of values, as can be observed for r-deletion in the environment -V(r)C ; in another environment, the range of values may be much greater, as for r-deletion in the environment -V(r)ʃ for example.

Figures 16 to 20 inclusive show percentage deletion of /r/ by education and style:

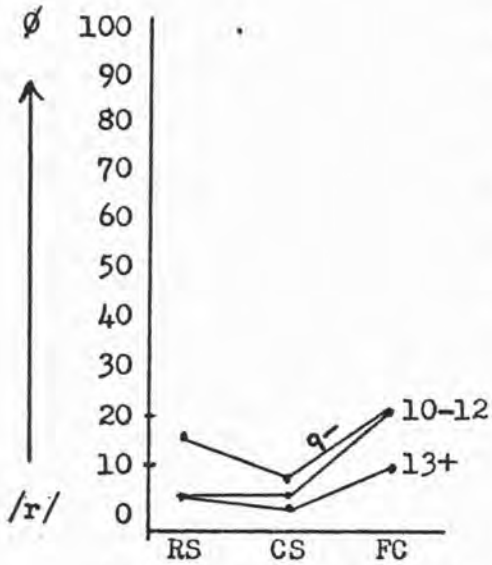

Fig.16: Percentage of r-deletion in the environment -V(r)C

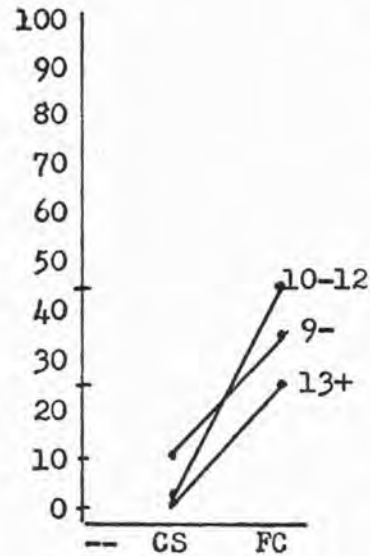

Fig.17: Percentage of r-deletion in the environment C(r)w

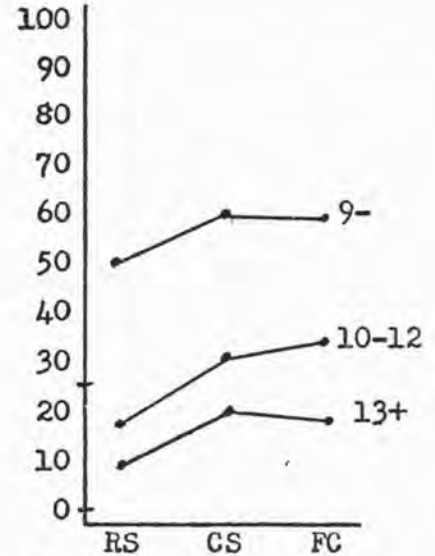

Fig.18: Percentage of r-deletion in the environment -V(r)H

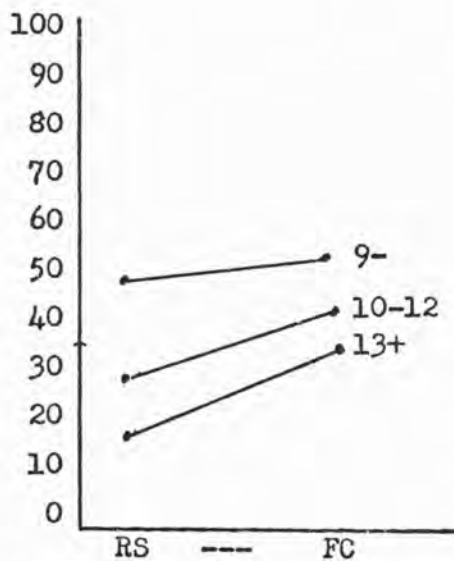

Fig.19: Percentage of r-deletion in the environment -V(r)H C

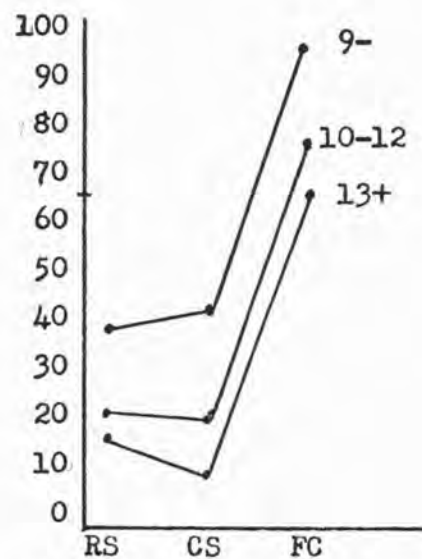

Fig.20: Percentage of r-deletion in the environment -C(r)H

Speakers do not react in the same way towards different linguistic variables, and therefore it is not surprising to find that similar behaviour may be found within one variable, where different phonetic environments are involved.

As can be observed from the examination of speech styles, all groups of speakers show awareness of r-deletion by decreasing its use when moving to more formal speech styles. For all phonetic environments this awareness is manifested by the downward slope of the lines as speakers move from less formal to more formal speech situations. Such awareness of a linguistic variable may lead to hypercorrection by some speakers. As Labov states:

" One of the most solidly established phenomena of sociolinguistic behavior is that the second-highest status group shows the most extreme style shifting..." (1).

Usually, this group shows hypercorrection by going beyond the highest status group in realizing a form carrying more prestige in more formal speech styles. In the case of r-deletion in the environments $-V(r)C$ and $C(r)w$, there is no such hypercorrection by the second-highest educational group. On the other hand, this group shows the greatest style shifting and displays a pattern of behaviour similar to that of the highest educational group in the two environments mentioned above, whereas its pattern of behaviour in formal conversation more nearly resembles that of the lowest educational group. This behaviour is probably explained better in terms of linguistic insecurity towards some forms of speech, whereby those who have had between 10 and 12 years of education show more awareness of /r/ in some environments by displaying greater style shifting.

(1) W.Labov, (1970), p.197

For all other phonetic environments and speech styles, however, all groups show the same degree of awareness of the presence of /r/ by displaying the same pattern of style shifting. A very regular social structure emerges in respect of r-deletion, in that all groups are differentiated at the same level of significance whatever the contextual style and the phonetic environment considered. This regularity in educational structure is nearly the same as that found for the study of diphthongization (cf. sub-section 2 of section 2.4.3.4).

Another interesting factor to be considered is that which concerns the degree of awareness of /r/ by speakers in different phonetic environments. For the environments C(r)w, and -C(r)ʃ, the degree of style shifting is greater than for the other phonetic environments. Speakers therefore seem to be more aware of r-pronunciation in these two environments. In addition, the significant discrepancy between speech styles concerns the opposition of formal and of less formal speech situations. There is only one exception to this relationship and it concerns /r/ in the environment -V(r)ʃ. In this environment, the discrepancy is found rather between reading style and the two other contextual styles. Reading style alone accounts for some awareness of r-pronunciation in this phonetic environment. This pattern of behaviour might be explained in terms of phonological environments and of the quantity of information transmitted. The phonetic information transmitted by the pronunciation of /r/ is probably less great when /r/ is found finally after a vowel, since its deletion may be compensated for by the length of the vowel. As Gendron mentioned, r-deletion could be due to an insufficient length attributed to this liquid, but, in compensation, vowels are longer than in Standard French. What is interesting to recall is that use of diphthongized vocalic elements was

also often made at the same level in careful style and formal conversation. This fact does not mean that use of diphthongization implies use of r-deletion, but it serves only to indicate the fact that vowels are realized as very long in Trois-Rivières French and that, surprisingly enough, both diphthongization and r-deletion are realized at the same level in careful style and formal conversation where the environment $-V(r)\#$ is concerned. This factor probably indicates that awareness of r-pronunciation may be related to the amount of information /r/ carries. In the environment $-V(r)\#$ and even in the environment $-V(r)\# \#C$, the loss of information through r-deletion may be compensated for by the length of the vowel, less attention therefore being paid to r-pronunciation in these environments.

2.6.2.4 Differentiation by occupation

Table 29 gives the proportional responses to r-deletion by occupational groups. From an examination of this type of grouping, a very regular social structure emerges. The following significant ordering remains constant for all contextual styles and phonetic environments: Professionals < white collar workers < manual workers.

This type of social structure relates perfectly to that found in the study of educational groups. In the environment $-V(r)C$, white collar workers, i.e. the second-highest status group, have scores of r-deletion which are in between those of professionals and manual workers in more formal speech styles, i.e. $P < WCW < MW$, whereas their

/r/ → ∅		P	WCW	MW
-V(r)C	RS	.025	.081	.168
	CS	.009	.054	.084
	FC	.124	.210	.233
-C(r)w	CS	.000	.066	.083
	FC	.256	.360	.534
-V(r)#	RS	.037	.162	.531
	CS	.103	.357	.620
	FC	.100	.329	.628
-V(r)#C	RS	.128	.300	.478
	FC	.331	.379	.569
-C(r)#	RS	.175	.200	.350
	CS	.075	.200	.390
	FC	.651	.766	.952

Table 29: Proportional responses to r-deletion by environment, occupation and style.

behaviour towards r-deletion approaches that of manual workers in formal conversation, i.e. $P < WCW$ and MW . This factor indicates that in specific phonetic environments, the second-highest status group shows more insecurity towards r-deletion by displaying such behaviour. In all other cases, this group of speakers shows the same awareness of r-pronunciation by their similar pattern of style shifting and in addition, all groups stay differentiated at the same level of significance whatever the phonetic environment and the contextual style involved.

The different degrees of style shifting found in the study of educational groups remain constant here. The environments C(r)w and -C(r)¶ are here again the two environments in which the greatest style shifting is to be observed. This factor confirms that speakers are more aware of r-pronunciation in these two environments.

The same pattern of opposition of formal v. less formal speech styles remains constant in the comparison of occupational groups also. Usually, these groups of speakers decrease their use of r-deletion when they move to both reading and careful styles. In the environment -V(r)¶, however, the significant style differentiation concerns reading style v. careful style and formal conversation. The explanation given in section 2.6.2.3 stating that loss of phonetic information through r-deletion is being compensated for by the length of the vowel in the environment -V(r)¶ remains valid in this case.

Thus far, variable (r)-2 has been seen as a stable sociolinguistic marker, i.e. a variable where educational and occupational groups are significantly differentiated from each other, and which is involved in stylistic variation.

The sex parameter will now be briefly examined, although of lesser importance in accounting for social variation.

2.6.2.5 Differentiation by sex

Figures 21 up to 25 inclusive show the pattern of behaviour of sex groups towards r-deletion by style and

The following 5 figures give the responses to r-deletion by sex and style.

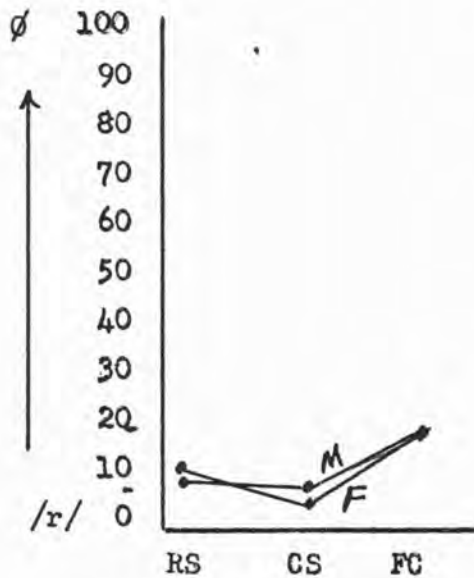

Fig. 21: % of r-deletion in the environment -V(r)C

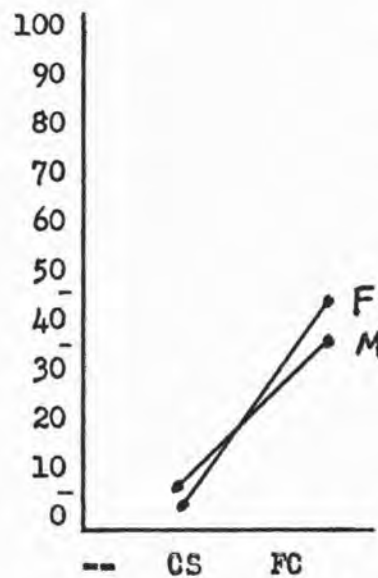

Fig. 22: % of r-deletion in the environment C(r)w

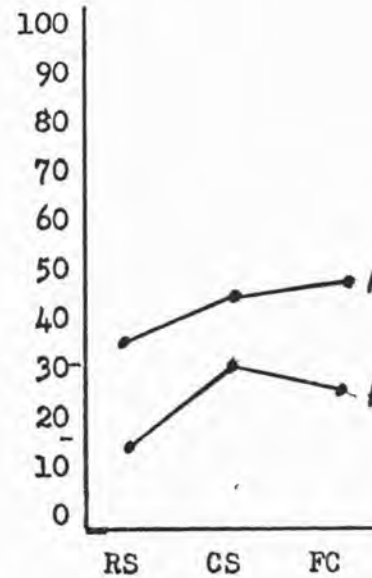

Fig. 23: % of r-deletion in the environment -V(r)†

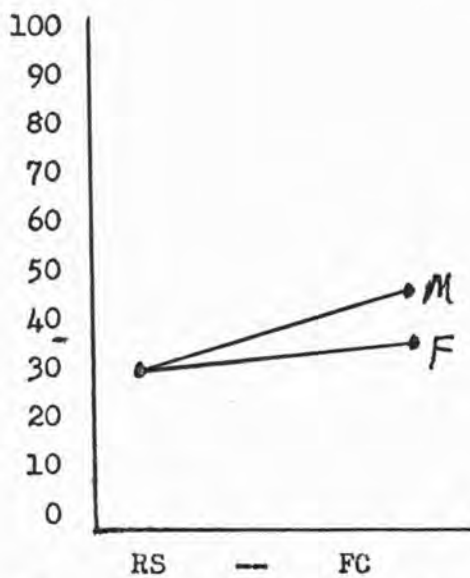

Fig. 24: % of r-deletion in the environment -V(r)††C

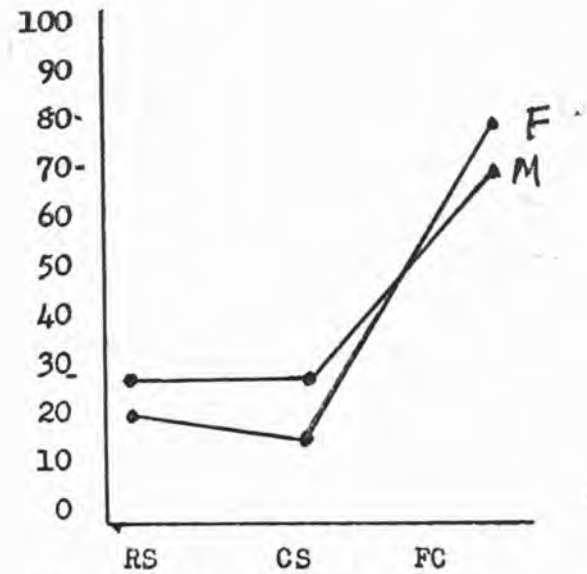

Fig. 25: % of r-deletion in the environment -C(r)††

phonetic environment. It is immediately apparent that the discrepancies between sex groups are far less significant than those found by educational and occupational groups. There are, however, interesting patterns of behaviour in respect of different phonetic environments.

In sections 2.6.2.3 and 2.6.2.4, it was found that the degree of style shifting in the environments $C(r)w$ and $-C(r)\#$ was greater than in the other environments. Speakers showed more awareness of r-pronunciation by greater style shifting in these two environments. What is very interesting to note is that the same applies in the comparison of sex groups and moreover it is in these two environments that a reverse pattern of style shifting is to be observed. Generally in fact, women behave either in the same way as men or have lower scores of r-deletion than men, especially in the environment $-V(r)\#$. In the environments $C(r)w$ and $-C(r)\#$, however, women show a sharper slope of style shifting. Since they use r-deletion slightly more often than men in formal conversation and since it was seen that it was to these environments that most attention was paid by all other social groups, it is not surprising to find women behaving as they do. As Labov found in the social stratification of (th) for example, women are more sensitive than men to a prestige pattern (1). They show this awareness in a greater slope of style shifting as they move to more formal speech situations.

In the remaining phonetic environments, women delete /r/ slightly less frequently than men and this especially when /r/ is in the environment $-V(r)\#$, in which important educational and occupational differences were also found.

(1) W.Labov,(1970),p.197

The patterns of style shifting found in the five phonetic environments for r-deletion are exactly the same as those found in the study of other sociological parameters and the discussions on style shifting through the study of these parameters remain valid in this case.

Since most groups of speakers examined were segregated at the same level of significance in all contextual styles, examples of speech to illustrate the behaviour of individuals towards r-deletion will be taken from formal conversation only. In addition, these examples will serve to illustrate the patterns of behaviour towards use of [r] or [R] and towards opening of half-open segments, as was studied in section 2.4.4.

Professionals: 13 or more years of education

- M.1.1 [lə parle dətɛl fasɔ̃ avɛk tɛl ʒã:f dapɛsɔ̃/ɔ̃ pø
dʒiː kə se pɔ natʃyrel / me ə (pɔ dakvɔ̃f/ (truy
kə sa vɛ:t / ...]
"le parler de telle façon avec tel genre de personne,
on peut dire que c'est pas naturel, mais je suis pas
d'accord. Je trouve que ça va être, ..."
- M.1.2 [sɛʁɑː / (kɔwa ʒmã) ɛtrɛ ɥn mezɔ̃ a lɛkstɛrʒɔːʁ dla
vil]
"Seigneur! Je crois (que) je m'achèterais une maison
à l'extérieur de la ville".
- [nɔ̃ / jø y de blɛsɛ me pɛʃsɔ̃n də mɔːt]
"Non, (il) y a eu des blessés, mais personne de mort".
- [jã syʁmã de dʒifɛrãːs dã la vil da twɔ ʉɥjɛː]
"(il) y a sûrement des différences dans la ville
de Trois-Rivières".

F.1.3 [ʒ pɛzjɔ̃e prɔʒe / kɔ̃m tʰul mɔ̃d dajA:]

"j'ai plusieurs projets; comme tout le monde d'ailleurs".

[ɥn vwatsyʁ dɑ̃ z œ fose / pi la pɛʁsɔ̃n etɛ ɑ̃kɔʁ
lɔ̃ / ɔ̃ ʁavɑ̃n d kebək ny zõt]

"une voiture dans un fossé, puis la personne était encore là. On revenait de Québec nous autres".

[paʁs ka ʒɔ̃ œ gro pɑʁle / tse ʒvɔ̃ dʒɛʁ / se pɔ̃
ʁafine / dajɔ̃ :β / lœ :ʁ tʁavaːj pɑ̃ de zɔ̃m fɔ :ʁ]

"parce que (ils) ont un gros parler; tu sais (ce que) je veux dire. Ce(n)est pas raffiné. D'ailleurs, leur travail prend des hommes forts".

White collar workers: 10 and 12 years of education

M.2.3 [nɔ̃ əwɛk de hɑ̃ ka ʃkɔ̃nɛ piʁs / ʃpaʁ pɛy ʒwal /
magre ka / kɑ̃ ʃtɛ ʒœn / ʃpaʁlɛ dɛtɛm / ʒə
ʁgɔ̃ dɛ bɔku a te ve]

"Non, avec des gens que je connais plus, je parle plus "joual"; malgré que quand j'étais jeune, je parlais dans les termes. J'é regardais beaucoup la TV".

M.2.8 [si ɔ̃ fəzɛ sɛplamɑ̃ œ n ɛfɔ : dɑ tɑ̃sjɔ̃ / pɔʁ
awɑʁ ɥn dʒɛksjɔ̃ mɛʒɔ :ʒ]

"Si on faisait simplement un effort de tension pour avoir une diction meilleure".

[ʒe negliʒɛ dɑ ʁɔʒɑʁdɛ dɑ nyvo avɑ̃ dɑ ʁɛpɑʁtɛʁ /
ʁɑ̃dʒy ɑ̃ plɛ mljɔ̃ dlɛtɛʁsɛksjɔ̃ / la mɛsjɔ̃ ɑ̃tʁɛ
dɑ̃ mɔ̃ notomobil /.../ ʒetɛ ɑ̃ tɔ : /.../ kɛ vnɛ
ʒystɛmɑ̃ dɑ tɔʁn^we ɑ̃ lɑ twɔ̃zjɛm mɛzɔ̃ / pɛs lõt ry
ɛ tʁɛ pʁɔʃ]

"j'ai négligé de regarder de nouveau avant de repartir. Rendu en plein milieu de l'intersection, le monsieur entra dans mon automobile. J'étais en tort... qui venait justement de tourner à la troisième maison, parce que l'autre rue est très proche".

- F.2.5 [a: bjɛ̃ / pət^hɛ:t ə / œ bo vwája:ʒ̣ pʊ tʏt la
famɪj]
"Ah! bien, peut-être; un beau voyage pour toute la
famille".
- [la ʒwal sɔ se/ stɛkstɔ̃dʒinɛ: / .../ kə le ʒã
sɛksprɪm də sɛt manʒɛ:r lɔ̃]
"le joual ça c'est; c'est extraordinaire que les
gens s'expriment de cette manière là".
- [e pʊi ʒmã dmã:d mɛm si ʒapʁuv le li:v/ u le
pjɛ:s də teɑ:t]
"et puis je me demande même si j'approuve les livres
ou les pièces de théâtre".

Manual workers: 9 or fewer years of schooling

- M.3.4 [õ pa:l kɔ̃m ø zo:t / dãl svdɔ/ tãkvɔ parɛ̃.j / pal
kɔ̃m ny zo:t/ nɔ̃ pɔ dɔ twɔ rivjɛ̃.]
"On parle comme eux autres. Dans le sud, (c'est)
encore pareil. (ils) parlent comme nous autres.
Non, pas de Trois-Rivières".
- [stɪn mɛtɔd də pãrle/ se tʏt / nɔ̃ }* pɔ dakɔ̃/
pãrs kə õ pãl pɔ bɛ̃]
"c'est une méthode de parler. C'est tout. Non,
je suis pas d'accord, parce qu'on parle pas
bien".
- [sɛlyɪ̃ ki sɔ̃ dɪnɪvɛ̃ste/ i parl mjø]
"celui qui sort de l'université, il parle mieux".
- F.3.5 [i dʒize tvʒvɔ̃r / vu z ɛt pɔ dʒisi/ mɛ puvɛ pɔ dʒɪ
kə õ vnɛ dɔ twɔ rvjɛ̃:]
"Ils disaient toujours: vous(n)êtes pas d'ici. Mais
(ils) pouvaient pas dire qu'on venait de Trois-
Rivières".

[de zɛksprɛsjɔ̃ ki dʒi:z/ ny zo't ɔ̃ vɔ dʒi:R / ɔ̃ vɔ
fɛ·la sjɛ·s / ø zo't vɔ̃ dʒi·R/ ɔ̃ va:le setʰ:dR]

"des expressions qu'ils disent. Nous autres, on va dire: on va faire la sieste. Eux autres vont dire: on va aller s'étendre".

[ɔ̃ vɔ fɛ·R mwɛ̃ atʰsjɔ̃ / sa va·vwɛ̃· la mɛ·m sɪnɪfikasjɔ̃]

"On va faire moins attention. Ca va avoir la même signification".

[a parl kòm ka ma']

"Elle parle comme qu'elle marche".

F.3.8 [nɔ̃ pas kə/ hla ga·dræ pɔ̃ pur mwe/ pax kalahã fae
pɔ̃ l bɔ̃nɛ̃:]

"Non, parce que, je le garderais pas pour moi. Parce que l'argent fait pas le bonheur".

[ʒɛm mjø awɛ̃· de pɛrsɔ̃n alãtur da mwe ka dlɑ̃ʒã]

"j'aime mieux avoir des personnes alentour de moi que de l'argent".

2.6.2.6 Summary

r-deletion in five main phonetic environments is not an innovation of Trois-Rivières French, but rather a phonetic phenomenon originating in the dialects of France, mainly of the 17th and 18th centuries. As noted by Gendron, this weakening in the articulation of /r/, leading to its disappearance, could be due to insufficient length attributed to this liquid. Juneau concludes his chapter on r-deletion by stating:

"Le fait qu'en québécois ancien on rencontre de multiples signes de "désarticulation" de r , signes qui ont d'ailleurs subsisté en bien des cas jusqu'à présent, n'est pas dénué d'intérêt pour l'histoire du français. C'est une preuve de plus qu'en français cette consonne n'a pas été aussi résistante qu'on a pu le croire, notamment en positions implosive et finale" (1).

This "historical" r-deletion is at present maintained in Trois-Rivières French, as has been seen above. All individual speakers participate in the application of this rule, whereby /r/ → ∅ , with a majority showing optional deletion of /r/ in more than one environment at a time.

r-deletion seems to constitute a stable linguistic marker, which shows both stylistic and social stratification. These factors represent the development of social reaction and the attribution of social value to the variable. As was seen in the study of the age parameter, r-deletion is not undergoing linguistic change at present. However, as is often the case, a change might also start in a sub-group of the community and from there spread to other groups. It is clear from the results that a certain change in r-deletion is taking place since it is involved in social and stylistic variations.

In the social structure, the significant ordering to account for use of r-deletion is as follows:

Professionals and informants with 13 or more years of education <

White collar workers and informants having had between 10 and 12 years of schooling <

Manual workers and speakers with 9 or fewer years of schooling.

(1) M. Juneau, (1972), p.172

This social structure is regular for all contextual styles and phonetic environments, although some cases of greater style shifting by women, by informants with between 10 and 12 years of education and by white collar workers were found.

The pattern of style shifting is dependent on the degree of awareness of r-pronunciation. Usually, this awareness is demonstrated by the downward slopes of the lines as speakers move from a less formal speech situation to more formal ones. This can be mainly observed in the environments $C(r)w$ and $-C(r)\#$. In the other environments, the style shifting is less important. In the environment $-V(r)C$, the presence of a less important style shifting may be attributed to the degree r-deletion is used in formal conversation. Since all speakers delete /r/ the least in this environment, the need to reintroduce /r/ in more formal speech situations is not felt as strongly. This fact is confirmed by the patterns of behaviour of speakers in the environment $-C(r)\#$. This environment is in fact the one in which r-deletion is the most favoured. It is also in this environment that the highest style shifting is to be observed in all groups.

Style shifting is not as important where the environments $-V(r)\#$ and $-V(r)\# \#C$ are concerned. Less attention being paid to r-pronunciation in these environments would not be due to the degree that r-deletion is used in formal conversation, but rather to the degree of information given by /r/. In these two environments, the information lost through r-deletion is probably compensated for by the length of the vowels.

The study of variable (r)-2 has given further empirical evidence for the assumption that, real, socially

meaningful differences between individuals or groups of individuals are very often differences of degree, rather than categorical differences. These differences of degree which differentiate speakers socially also serve to indicate differences between one style of speech and another and between one phonetic environment and another. For example, a higher r-deletion rate may be more easily observed in the environment -C(r)H, in a less formal style of speech, by male, by less educated speakers and manual workers.

2.6.3 Conclusions on variable (r)

The study of variable (r) has offered two different types of linguistic and social structures. In this study of one consonant, it was seen how complex linguistic phenomena may be, and that these complex linguistic patterns could not always be accounted for in terms of one theory alone.

The actual usage of variables may in fact offer different kinds of distribution, whether linguistic change is taking place or not. The simplest of all cases concerns a variable which has no social nor stylistic significance. It is a case of change through "random drift". Although Labov talks of this type of change as being a "theoretical probability" (1), variable (r)-1, or use of [r] or [R], has proved to be such a case. In the study of this variable, it was in fact found that use of an alveolar or uvular trill was undergoing linguistic change, in which a uniform change from one age level to the other could be observed, with

(1) W.Labov, (1966a), p.324

young speakers at the end using the uvular variety [R] almost exclusively. Neither social class nor stylistic variations were found within the process of this change. With age, however, sex appeared to be an important factor to account for differences within the speech community and, through this, it could be observed that women were often more aware than men of a linguistic change in progress, or rather that women, independent of their education or occupation, were the leading group in the change together with young speakers.

The rule /r/→[R] seems to have been adopted fairly quickly by young speakers and women, so that no social value could be attributed to this variable. In such cases, Bickerton's theory finds an almost perfect application. In the course of such a rapid change, in which there are no social or stylistic variations, there is in fact "a series of changes in obligatory rules, each introduced by a period of optionality" (1). These changes are affected in such a way that a majority of 52 speakers are seen to apply either /r/→[r] or /r/→[R] categorically, with only a minority of 8 informants displaying optionality in the choice of either one rule or the other. However, the pattern of optionality found by 8 speakers counters Bickerton's theory in that it is applied to all phonetic environments at a time, i.e. when optionality in the application of a rule is present, there are more chances to observe it in all phonetic environments where the rule can apply rather than in only one environment at a time.

Bickerton's theory on variability is far too extreme, since it limits individuals to the ability to operate mainly in terms of categorical application of linguistic rules, leaving a potential capacity for dealing with variability and optionality under very restricted conditions.

(1) D. Bickerton, (1971), p.458

The study of variable (r)-2 , or of the alternation of /r/ with zero, has shown that, at least for some linguistic features, individuals are in fact perfectly capable of dealing with variability and optionality, even over long periods of time, and that optionality in the application of a particular rule could affect all phonetic environments where this rule applies.

Variable (r)-2 is a linguistic marker, i.e. it serves to mark social and stylistic differences. Where such differences are present, it is usually due to variable behaviour in the speech of individual speakers. This variable behaviour was in fact present for almost all informants who showed optionality in the application of the rule /r/→∅ in more than one phonetic environment at a time.

The same phonological constraints operated for all speakers, i.e. that they deleted /r/ in five environments and never in others. However, the areas where r-deletion could take place were represented in the speech of all individuals. The degree to which each speakers participated in r-deletion depended , however, largely on his educational level and on his occupation, as well as on the level of consciousness this speaker had of the variable.

Thus, relative proportions of rule application, such as /r/→∅ , can be incorporated into social, stylistic and linguistic structures, and the differences between social groups, styles of speech, and phonetic environments need not be categorical to be meaningful. On the contrary, it seems as though variability exists as an ordinary aspect of the linguistic competence of individuals, as has already been shown by the patterns of behaviour of individuals towards variable (a)-1,

diphthongization, opening of half-open segments, and variable (r)-2 .

What must also be added is that not only are speakers able to operate in terms of variability towards certain linguistic features, but also that they are able to operate in terms of degrees of variability. This fact is demonstrated by the behaviour of those speakers who can recognize too high a usage of some forms of speech, e.g. usage of 65% deleted /r/ in the environment $-C(r)\#$ by professionals in formal conversation, by reducing the incidence of these forms in more formal speech situations, e.g. professionals who dropped the number of deleted /r/ by almost 60% in careful style. Thus, speakers seem to be able to operate both in terms of variability and degrees of variability, although speakers deal categorically with many linguistic rules.

Taking account of all these factors, the processes involved in variable (r) may be summarized in the following form:

Variable (r)-1

- 1- categorical application of the rule $/r/ \longrightarrow [r]$
28 informants;
- 2- categorical application of the rule $/r/ \longrightarrow [R]$
24 informants;
- 3- Optional application of the rule $/r/ \longrightarrow \langle [R] \rangle$
8 informants.

Variable rule: $/r/ \longrightarrow \langle [r - R] \rangle$
f (age,sex)

Variable (r)-21- Phonological constraints

$$/r/ \text{ never } \longrightarrow \emptyset \quad / - \left\{ \begin{array}{l} \#/r/ - \\ -V/r/V \\ -V/r/\# \# V- \\ -C/r/V \\ -C/r/u \end{array} \right\}$$

$$/r/ \longrightarrow \langle \emptyset \rangle \quad / - \left\{ \begin{array}{l} -C(r)w \\ -V(r)C \\ -V(r)\# \\ -V(r)\# \# C \\ -C(r)\# \end{array} \right\}$$

2- Variable rule for r-deletion

$$/r/ \longrightarrow \langle [r, R] - \emptyset \rangle \quad / - \left\{ \begin{array}{l} -C(r)w \\ -V(r)C \\ -V(r)\# \\ -V(r)\# \# C \\ -C(r)\# \end{array} \right\}$$

f (phonetic environment, education and occupation, style, sex)

With these conclusions on variable (r), the survey of the differentiation of the linguistic variables to be studied has been completed. The investigation of variable (a)-1, of the use of archaic phonetic features, of the diphthongization of long vocalic segments, of the opening of half-open segments, and finally of variable (r) has demonstrated the complexity of these linguistic features. The phonetic features mentioned

above represented, in fact, areas in which variation in the speech of individuals and of groups of speakers was present. This variation was seen to occur not at random but, on the contrary, as an integral part of the structure of Trois-Rivières French. All variables appeared in fact to be part of linguistic, social and stylistic structures.

However, even though inferences about social significance of linguistic variables have been drawn from speech data and from the observation of the objective performance of speakers, there is another dimension one must consider. This concerns the subjective attitudes of speakers towards their own language. As was seen in section 2.3.4 on "joul", and in the study of archaic phonetic features, many subjective attitudes are directed towards these forms of speech and these attitudes helped to explain certain linguistic behaviour towards these same forms.

Subjective attitudes are interesting to observe since they can reveal much about the degree of awareness speakers have of some linguistic features as well as the degree of linguistic security or insecurity present in speakers. Chapter 3 will therefore be devoted to the study of the subjective attitudes of the sixty informants interviewed.

Chapter 3

General attitudes towards Trois-Rivières French

3.0 Subjective attitudes towards Trois-Rivières French

In this chapter, general attitudes of Trifluvians towards their own language will be studied. Information concerning these types of attitude can be obtained through direct questioning: general approval or disapproval, comparisons with other forms of regional speech, feelings about what is correct usage and what is not, the need to change one's language, etc. Responses obtained from questions of this type involve emotional attitudes towards language, through which a lack or presence of linguistic insecurity within a community can be detected.

The questions on linguistic attitudes were not asked with equal rigour, i.e. with some informants the discussions were long, whereas with others they were briefer. However, most of the informants showed great interest in the completion of this last part of the interview (cf. Part IV of the questionnaire, appendix).

In the course of this study, it was seen that most variables lay below the level of conscious awareness, i.e. that they were realized differently in natural conversation as compared with more formal speech situations. Since these two speech situations generally offer two different structures, it may be said that most variables are below the level of awareness in formal conversation, although they are governed by a degree of self-control imposed on the patterns of native speech in more formal speech contexts, through which the forms considered as the norm appear more clearly. In the answers on language topics, however, very few informants perceived or reported their own variant usage of the phonological

variables. This does not mean that the Trifluvians interviewed do not give a great deal of conscious attention to their language, as in fact was the case when their behaviour towards phonological variables was considered in formal speech styles. Moreover, most of the informants have strong opinions about language, and they express them without hesitation. Their attention is however mostly focused on items which have risen to the surface of social consciousness, for example on archaic phonetic features. Usually, therefore, the perception of language does not concern one's own experience, but rather socially accepted statements about language.

3.1 Recognition of Trifluvians by outsiders

The informants were asked if they had ever travelled outside Trois-Rivières, and if they had ever been recognized as Trifluvians by their speech. Very few informants had never been outside the city limits, even on vacations; but for all those who had left the city sometimes, it does not seem to have been a common experience that they were recognized as Trifluvians by their speech alone. The common shared experience seems rather to have been that all Trifluvians had been recognized as coming from the province of Québec, i.e. as speaking Québec French, but not particularly Trois-Rivières French.

The informants who said they had never been identified as Trifluvians through their speech specified that this has been the case, since Trois-Rivières is an "accentless" city, i.e. that a type of general Québec French accent is found in this city rather than strong "accents which one can find in the regions of Québec city, Gaspésie, Lac St-Jean, etc.

	EDUCATION			PROFESSION			SEX		AGE		
	<u>13+</u>	<u>10-12</u>	<u>9-</u>	<u>P</u>	<u>WCW</u>	<u>MW</u>	<u>M</u>	<u>F</u>	<u>15-24</u>	<u>25-44</u>	<u>45+</u>
1-Recognition of Trifluvians by outsiders											
YES	10	1	0	9	2	0	7	4	7	2	2
NO	15	16	18	11	18	20	23	26	11	16	22
AS NON-TRIFLU- VIANS.	1	0	0	1	0	0	1	0	1	0	0
2- Recognition of linguistic differences between country and town.											
YES	21	9	10	17	11	12	20	20	14	15	11
NO	4	8	8	3	9	8	10	10	4	3	13
3- Recognition of social ac- cents within Trois-Rivières											
YES	17	6	9	14	9	9	16	16	10	13	9
NO	8	11	9	6	11	11	14	14	8	5	15
4- Attitudes towards "joyal"											
ACCEPT IT	17	4	11	11	9	12	21	11	14	9	9
DO NOT ACCEPT IT	5	10	2	6	8	3	6	11	2	5	10
NEUTRAL	3	2	2	3	2	2	2	5	1	4	2
5-Attitudes towards Trois- Rivières French											
POSITIVE	20	8	11	14	13	12	22	17	16	10	13
NEGATIVE	2	4	1	3	2	2	3	4	0	4	3
NEUTRAL	3	4	4	3	4	4	4	7	2	4	5

	EDUCATION			PROFESSION			SEX		AGE		
	<u>13+</u>	<u>10-12</u>	<u>9-</u>	<u>P</u>	<u>WCW</u>	<u>MW</u>	<u>M</u>	<u>F</u>	<u>15-24</u>	<u>25-44</u>	<u>45+</u>
6- Efforts to change one's language.											
YES	12	12	6	10	13	7	11	19	6	11	13
NO	12	5	10	10	6	11	18	9	12	7	8
7- Recognition of one's different levels of language.											
YES	13	5	4	9	7	6	15	7	11	7	4
NO	12	11	12	11	12	12	14	21	8	10	17
8- Is language a factor through which judgments can be made?											
YES	22	15	13	17	18	15	24	26	17	14	19
NO	2	1	3	2	1	3	3	3	1	2	3

Table 30: Responses to questions on linguistic attitudes by sixty Trifluvian informants.

For these informants Trois-Rivières has no typical "accent".

On the other hand, some informants recognized that they had been identified as Trifluviens through their speech.

"Mais, on arrive à l'extérieur là, puis c'est pareil comme si c'était écrit dans notre face. Je pense qu'on va rouler les r plus qu'ailleurs à Trois-Rivières"

reported one of the youngest informants, a 23 year-old professional. Four other informants referred particularly to [r]

as being a characteristic of Trois-Rivières French. The remaining informants viewed some aspects of the vocabulary and idioms characteristic of Trois-Rivières, as being features through which they had been identified as Trifluvians.

Only one informant, a young male professional, said that although he had sometimes been identified as Trifluvian, he had mostly been identified as an outsider, i.e. as someone coming from the region of Québec city. The reason he gave to explain this lay in his use of a uvular [R] as opposed to the more commonly used [r]. The experience of this young informant demonstrates that the linguistic change affecting use of an alveolar [r] in Trois-Rivières has probably taken place very rapidly. Although it was in fact observed that most young speakers now used the uvular variety [R] (cf. table 25, section 2.6.1.1), this change does not seem to have been recognized yet, so that those speakers who use [R] could easily be identified as outsiders. This factor is interesting to note since it shows the degree of awareness which speakers may have of certain phonological variables.

Nearly half of the more educated informants and professionals reported that they had been identified as Trifluvians, whereas only 6% of the informants with between 10 and 12 years of schooling and 10% of white collar workers recognized this fact. None of the less educated speakers and none of the manual workers had the experience of being identified as Trifluvians. There is also an interesting age differentiation to be observed from table 30 in which 42% of the youngest informants claimed to have been recognized as Trifluvians through their speech, whereas only 11% of the middle-aged group and 8% of the oldest group recognized this.

From the analysis of responses to other questions on linguistic attitudes, conclusions on these differences will be drawn.

3.2 Recognition of linguistic differences between country and town.

The informants were asked if they saw any differences between the speech of people living in the nearby country and the speech of Trifluvians. Over 80% of the more educated informants and professionals thought that people living in the country used different expressions and also different pronunciations from those of people living in a town. Between 50% and 60% of the two other educational and occupational groups showed the same attitude. The informants who viewed country and town as being linguistically different reported that such differences were due to the occupation of the country people, which is considered as harder physically, and also to the level of education of these people.

The remaining informants considered that previous differences between country and town no longer existed. They attributed this to the influence of radio and television and also to the fact that nowadays town and country children go to the same schools.

What can be observed already from these attitudes is that all informants are aware of certain speech differences. Although some informants thought that there were no longer linguistic differences between country and town, all of them nevertheless showed awareness of linguistic features, since

they regarded radio, television, level of education and work as criteria through which differences in "accents" could occur or disappear.

3.3 Recognition of social accents within Trois-Rivières.

Immediately after the question on recognition of regional speech differences, the informants were asked if they thought that all Trifluvians spoke in the same way or if some differences could be found between members of the community. 70% of professionals and nearly the same percentage of the most educated informants recognized the existence of social dialects within Trois-Rivières. 45% of white collar workers and manual workers recognized this fact, whereas 50% of the least educated informants and 35% of the informants who have had between 10 and 12 years of education were aware of the existence of speech differences within the speech community.

The informants who recognized differences within the Trifluvian community referred mainly to education as the most important factor in accounting for such differences. Some referred to a different dialect for each social class.

"Le journalier, il va parler le langage moins soigné qu'un médecin",

as was reported by a middle-aged female manual worker (inf. F.3.5). Other informants referred to the family, as being a major factor since it is within the family that a child learns to speak and how to speak. Occupation was also viewed as important:

"puis peut-être aussi le milieu de travail qui parfois, disons, force un individu à parler un peu "joual", où c'est mal vu peut-être de parler trop bien",

as was pointed out by a young male professional (inf.M.1.2). Some informants also referred to one's area of residence as an important factor. As a young male professional states (inf.M.1.6) :

"certains quartiers n'ont jamais de communication entre eux. A ce moment-là, ils ont pas beaucoup d'échange culturel, donc ils ont des expressions particulières(...) le quartier Normanville avec le quartier Ste-Marguerite, c'est pas des quartiers qui communiquent beaucoup entre eux, donc ils ont des expressions particulières".

The awareness of differences between various geographical areas of Trois-Rivières is interesting to note, since it represents in fact the Trifluvian geographical and social reality. As was seen in section 1.2.4 , Trois-Rivières is a city in which geographical areas very often represent specific social groups of the community, i.e. where geographical and social factors are strongly correlated.

A last factor which was also seen as important in accounting for social differences is the age factor.

"Mais avec des jeunes, puis des un peu plus vieux, vous allez voir une différence" ,

as was stressed by a 51 year-old female professional (inf. F.1.10).

All of these factors, i.e. education, family, occupation, place of residence, age, etc., are in fact important factors which can account for speech differences within a community. Generally, about half of all informants appear

to be aware of the existence of social differences within the community and, through that, of linguistic differences.

Some informants not only stressed the existence of speech differences within Trois-Rivières but also pointed out the linguistic areas where they thought such differences could be mainly found. As was seen in section 2.3.2, some of the informants referred to the use of archaic phonetic features as being a characteristic of less educated members of the community. Greater usage of English terms by manual workers was also mentioned:

"disons les classes; on peut parler de classes qui travaillent par exemple dans les moulins à papier. Il y a beaucoup de tournures anglaises",

as was pointed out by a young, male professional (inf.M.1.2). To mention the presence of more English terms in the speech of manual workers is not surprising, since major industries of Trois-Rivières, like the paper mills, are in the hands of the English speaking minority. This fact seems to have had the same influence on Trois-Rivières French, as it has had on Québec French in general (cf. chapter 1, section 1.1.2).

Apart from the references to usage of archaic phonetic features and English terms, which constitute the main characteristics of "joual", the informants referred to vocabulary and syntax as being areas where differences could be found. A 68 year old male professional (inf.M.1.8) said:

" et on a des gens qui ont pas eu les moyens, qui ont été ouvriers, qui ont vécu ensemble, puis qui ont conservé certaines expressions (...) avec malheureusement des expressions qui sortent du langage propre(...), qu'on n'emploierait pas dans nos familles".

A 27 year old female professional (inf.F.1.5) stated:

"Selon les classes sociales, c'est différent. Les intonations sont différentes, les expressions sont différentes, c'est-à-dire qu'on n'emploiera pas les même mots. La construction de phrases est différente aussi".

A 38 year old female manual worker (inf.F.3.5) stressed these aspects by giving such examples:

"Je prend mon cas à moi. (...) On va faire moins attention. (...) On peut dire "donne-moé ça". Dans les autres classes, ils vont dire "est-ce que tu peux me le donner".

These answers show that speakers are aware of social differentiations which can be expressed through linguistic features. Usually, however, most speakers showed more awareness of stigmatized linguistic features, such as moé and toé, than of any other linguistic features. Their attention is therefore mostly focused on items which have risen to social consciousness.

3.4 Attitudes towards "joual".

After having expressed their views on "social accents" within Trois-Rivières, informants were asked about their attitude towards "joual" and how they viewed this speech variety.

Section 2.3.4 of chapter 2 was specially devoted to the description of "joual", since this form of speech was related to usage of archaic phonetic features. Through the

examination of subjective attitudes, however, it will be possible to observe the reactions of Trifluvians towards "joual".

The first observation which can be made from the results of table 30, is that there are no differences between any group when the neutral reaction is considered. Around 11% of the whole sample has a neutral reaction towards "joual", i.e. viewing it as neither good nor bad. A majority of speakers, however, show strong reactions towards this speech variety in either accepting its use or in rejecting it completely.

When the informants who have clear-cut opinions about "joual" are considered, the following results occur: around 70% of the most educated informants and professionals, and more than 80% of the least educated speakers and manual workers accept the use of "joual" within the society. On the other hand, only 28% of the informants who have had between 10 and 12 years of schooling and 53% of the white collar workers group accept its use, the remaining informants rejecting "joual" completely. However, independently of the acceptance or rejection of "joual", this form of speech has been generally characterized as follows: bad pronunciation and anglicisms.

Within those who accept "joual", there are different degrees of acceptance to be observed.

A young male professional (inf.M.1.1) expresses a full admission of "joual" in these terms:

"le vrai joual. C'est dommage quand même à cause de l'anglicisme qui s'infiltré partout. Mais c'est la langue la plus vivante.

Pour nous autres, c'est une langue vraiment vivante. (...) Elle va inventer des mots nouveaux. Parler français, puis essayer de très bien s'exprimer, bien ça, c'est pour les français. (...) Notre façon va être beaucoup plus près du joual".

This young professional regrets only the presence of anglicisms in this form of speech. He nevertheless considers it as the only form of language through which people can really express themselves.

Another young male professional (inf.M.1.2) shows the same attitude towards "joyal" although he admits that it is full of anglicisms and that the pronunciation is imperfect. As he states:

"il y a beaucoup d'anglicismes là-dedans, puis de la mauvaise prononciation.(...) Mais je pense que le joual comme tel est bon parce qu'en plus des mots, il y a , il me semble, un message là-dedans, une façon de s'exprimer,(...) c'est une culture un peu qui parle".

To accept "joyal" completely and to see it as the vehicle of a culture is the view of 11 informants. Five of these informants are professionals with 13 or more years of schooling and 5 are manual workers with 9 or fewer years of education . In addition, seven of these informants are under 26 years of age. This last factor is interesting since it shows that young people may show more tolerant attitudes towards this speech variety than older people. This factor is confirmed by the behaviour of age groups in table 30, in which 81% of the youngest speakers show a positive attitude towards "joyal" against 50% of the middle-aged group and 42% of the oldest one who demonstrate the same attitude. The generally positive attitude of young speakers towards "joyal"

illustrates the tendency, called "joualisante", which was mentioned in section 2.3.4 of chapter 2. Through this tendency, a revival of "joual" can be seen amongst young people, who view this form of speech as the best means of expressing their own culture.

Thus far, attitudes reflecting a full admission of "joual" have been observed. The remaining informants who were classified under the heading accept it did in fact approve of "joual" but with reserve.

21 informants approved of "joual" only on some occasions, and especially to express sentiments such as joy, anger, etc., and for joking. On the other hand, they said one should use a better type of French when looking for a job, when talking with strangers, etc. For all of these informants, "joual" is considered as good but limited since it can only be understood within the limits of the Province of Québec. Therefore, the form of language to adopt for them is a more standard form of French. "Joual" nevertheless remains the most colourful and lively language to listen to although they would not accept it as the everyday language for themselves. "Joual" is seen by them as a speech variety suitable for specific domains of interaction, which are all related to intimacy and friendship, whereas for more official occasions, a "Standard French" is rather favoured.

The attitude of the remaining seventeen informants towards "joual" is entirely negative. They do not approve of its use for any member of the community, nor do they agree that it could express jokes and strong feelings in a more lively and accurate manner. They also condemn its use by playwrights and on television programs. "Joual" is viewed by them as a "deterioration" of the French language and therefore should be completely eliminated.

The negative attitude towards this speech variety is mostly represented in white collar workers, in informants with between 10 and 12 years of schooling, in women, and finally in older informants. The second-highest occupational and educational group is the most intolerant group, as far as its attitude towards "joual" is concerned. It was seen in the cases of variable (a)-1 (section 2.2.4) and of r-deletion (section 2.6.2.4) that white collar workers behaved as manual workers in formal conversation, whereas their pattern of behaviour was approaching that of professionals in more careful speech contexts, thus showing more linguistic insecurity towards these variables. It would therefore seem that the most corrective group, at least for some linguistic variables, shows the most negative conscious attitude towards a speech variety now considered as "bad" speech.

The results obtained from the examination of attitudes towards "joual" are similar to those obtained by Laberge and Chiasson-Lavoie, (1971), in their work in Montréal, in that the highest-status and the lowest-status group show more positive attitudes towards "joual", whereas the middle-ranking status group dissociates itself the most from it. However, before drawing more definite conclusions on the significance of these attitudes, the other questions will be examined.

3.5 Attitudes towards Trois-Rivières French

The question the informants had to answer concerned their attitudes towards general Trois-Rivières French. What

is most interesting to note in table 30 is that more informants show a positive attitude towards Trois-Rivières French than towards "joual". The positive attitude mainly concerns a clear agreement amongst all informants against Parisian French becoming the linguistic point of reference. All of them, without exception, rejected Parisian French as the norm to adopt. This factor clearly indicates a need for self-identification through language. However, although rejecting Parisian French as the norm, some speakers show a negative attitude towards Trois-Rivières French, whereas others consider it as acceptable. These two tendencies indicate the search for one's own linguistic norm, as previously mentioned in section 2.3.4 on "joual".

The groups which have more members showing negative attitudes towards Trois-Rivières French are: those who have had between 10 and 12 years of schooling, women, and finally older speakers as opposed to the informants aged between 15 and 24. Although more informants are favourable to Trois-Rivières French, the differentiations between groups of speakers are the same as those found when attitudes towards "joual" were considered.

The attitudes towards Trois-Rivières French are generally more favourable than towards "joual" since speakers feel the need to accept it, because it is the main form of language through which they can express themselves. On the other hand, many informants felt the need to improve it, as can be seen in responses to the next questions.

3.6 Efforts to change one's own language and
Recognition of one's different levels of language.

At least two-thirds of the white collar workers group, of informants with between 10 and 12 years of education, of women, and of older informants felt the need to correct their own language and did not feel happy about the way they spoke. This reaction is most interesting since it is exactly the same groups who showed a more negative attitude towards "joual" and general Trois-Rivières French. It would therefore seem logical to assume that, the more a speaker dislikes his language, the more efforts he will make to correct it.

The negative attitude towards the city speech is, in many cases, directed by the informant towards his own speech as well. The pressures towards a "better" French, often associated with the highest-ranking group's level of language in the mind of the speakers, are very strong. A 53 year old female manual worker reported this situation.

"Ca dépend devant quel public on se trouve.
 Bien, si on est avec quelqu'un d'un petit
 peu plus haut placé que nous autres, (...)
 si on ne fait pas attention à notre parler,
 des fois on peut se faire remarquer".

Such informants feel the need to conform to another form of speech when they do not interact within their peer group. A 33 year old shoemaker admitted that he was not happy about his speech in general and described it as "lousy". In consequence, he felt the need to correct his language in more official situations:

"Non, on se force. Quand on arrive à une
 place plus haute, si on veut, bien on se
 force. Il ne faut pas parler de même".

As to his own speech, he states:

"Non, je ne suis pas d'accord, parce qu'on ne parle pas bien. Bien parler, c'est de prononcer comme il faut..."

This informant shows insecurity towards his own language and represents the attitude of all other informants who wanted to correct their own speech. This need of correction is mainly directed towards a better pronunciation, a more accurate vocabulary, and finally, and to a lesser degree, better syntactic structures. This attitude could be described as a reaction to pressure from above, through which speakers feel insecurity towards their own speech and aim at correcting it.

There may, however, be equally powerful pressures from below. From such pressures, speakers are aware of the need for the style shifts, which were observed by means of the phonological variables. These speakers are conscious of the need to adapt one's own language according to the situation. This can be more easily observed in the answers on recognition of one's different levels of language, i.e. question 7.

In the answers to this question, it is very interesting to note that, generally, the groups who were in favour of "joual", who accepted Trois-Rivières French, and who showed less need to correct their everyday speech are the same groups who recognize to a higher degree the reality of one's different styles of speech, and vice versa. These informants are usually very aware of pressures from above and from below, i.e. that they are conscious of both influences in their language. A young male professional reported his own experience in these terms:

"je vais parler joual, puis je vais sacrer avec le monde qui sacre puis qui parle joual. Je vais essayer de parler mieux avec des gens qui s'expriment un peu mieux".

A 32 year old female professional showed the same attitude, saying:

"Non. Je ne parle pas toujours de la même façon. Je vais être avec un certain groupe de personnes, puis je vais faire beaucoup attention à mon langage. Puis il y a d'autres fois que je vais me laisser aller. Si je suis avec un groupe qui parle joual, je vais être portée plutôt à me laisser aller pour ne pas paraître pédante".

This attitude is very interesting since it shows a desire to conform not only with those who are regarded as speaking more correctly, but also with those who are identified as speaking "joyal". This latter case indicates pressures from below to which some speakers respond in order to be socially accepted and not to be identified as snobbish. Another young female white collar worker feels the same pressure by stating:

"Mais tu rencontres quelqu'un qui parle très bien,... les gens sont portés à rire de ça en disant: elle fait sa snob".

A young male manual worker who had had 13 years of schooling but who was working with unskilled workers at the time of the interview, explained how this factor had an effect on his speech:

"ça dépend du milieu avec qui je vais être. Comme je travaille ici dans le moment, alors je me laisse peut-être un peu aller. Je ne devrais pas, mais..".

The pressure from below is felt very strongly by this informant since he felt that he could speak more correctly but did not because of his environment.

All of the reactions reported above show the speaker's awareness of language. They feel the need either to correct their own language, or to leave it as it is. In addition, some groups of speakers are very conscious that their

society consists of different groups and that language reflects this reality. Not only are they aware of this reality, but moreover, they accept it by adapting their language according to the people with whom they are. On the other hand, although perhaps recognizing the same reality, other speakers do not react in the same way since they do not think of themselves as having different speech styles. These informants reported that they always spoke in the same way, whatever the situation, since they wanted to be natural and to remain themselves.

3.7 Is language a factor through which judgments can be made?

The last question put to the informants was asked in order to find out if informants viewed language as an indicator of someone's status.

As table 30 illustrates, the great majority of all informants recognized the fact that language provided reliable cues as to someone's social status. The general agreement on this question was that the level of education of a person could be easily identified through language. Informants agreed that they themselves passed judgment on the education of a person just by listening to his speech. Another common point of agreement amongst informants was that they refused to judge the personality, qualities, etc., of someone by language alone, since it could be misleading. However, they all felt that language was generally a good reflection of someone's occupation and level of education.

3.8 Differences in linguistic attitudes of various groups.

Men v. women

As the sexes' reports on linguistic attitudes are compared, a series of significant differences are found. These differences are found where attitudes towards "joual" and Trois-Rivières French are concerned and also where informants made an evaluation of their own speech (cf. questions 6 and 7). It can clearly be observed that men favour "joual" and Trois-Rivières French in a greater proportion than women. At the same time, men show less need to correct their own language although more men recognize themselves as having different levels of language. Women therefore show the highest degree of awareness of what they consider "good" speech and at the same time show much greater linguistic insecurity than men. These factors are confirmed by the patterns of style shifting of women, which were greater than those of men for almost all phonological variables studied. The subjective attitudes of men and women can therefore be seen as reflecting accurately their objective patterns of behaviour towards the variables examined in this study (1).

Occupation and education

These two sociological parameters are as important in accounting for differences in linguistic attitudes as they are in explaining different patterns of behaviour in the treatment of the phonological variables. There are two types of social structure emerging from the results in table 30.

(1) cf. W. Labov, (1966a), p. 495 for similar results

1- The first type of structure is shown by the first three questions. Through these questions, informants could express their awareness of the existence of different dialects concerning: Trois-Rivières as opposed to other geographical regions in Québec, Trois-Rivières as opposed to the nearby country, and finally different accents within Trois-Rivières itself.

The awareness of "accents" , either geographical or social, is mostly represented by professionals and the most educated informants. These two groups of speakers are significantly more conscious of the existence of different forms of speech than any other group, and this factor could be explained by their awareness of linguistic features. As was seen in section 3.3 for example, it is often informants of these groups who pointed out features such as pronunciation, syntactic structures, etc., as being areas where differences in speech could occur.

In addition, their patterns of style shifting towards phonological variables demonstrated their awareness of these. It is true that style shifting indicates linguistic insecurity and these groups are probably insecure about certain linguistic variables. On the other hand, their pattern of style shifting is more stable than that of white collar workers, since usually, they are clearly differentiated from other occupational and educational groups, which is not always the case for white collar workers. In addition, it was observed that professionals and the most educated informants were the leading groups in usage of more prestigious forms of speech. Socially speaking, these informants are most probably aware of their privileged social status and therefore may equally be aware of language as a reflection of regional and social differentiations.

2- The second type of structure which emerges from questions about approval or disapproval of language and about the need to correct or change one's language is different from that obtained from the recognition of different types of speech, since in the present case professionals and manual workers, and the most educated informants together with the least educated ones form the groups showing the most positive attitudes towards "joual" and Trois-Rivières French. In addition, these groups show the least need to change their language. These factors demonstrate that these groups of speakers are more secure about their language than the middle-ranking status group. It was mentioned in section 3.4 that white collar workers and the middle-ranking educational group showed the most linguistic insecurity towards some phonological variables. At the same time, they also display the most negative attitude towards "joual" and Trois-Rivières French and they express a stronger need to change their own language. The linguistic insecurity revealed here is probably due to the nature of the social class position of these groups. They are in fact in the middle of the two other extreme groups by their level of education, income, job's status, etc.

These factors might lead them to try to acquire more status by means of a "better" language, which they associate with the highest-ranking group's speech. Another factor which serves to verify the linguistic insecurity present in this group to a higher degree, is that it is this group which admits at a lower level that it can adapt its language according to the type of situation faced. The faculty of adapting one's own language according to external factors, or at least the recognition of such facts, demands a certain degree of linguistic security. This linguistic security seems to be lacking especially in the middle-ranking group (1).

(1) cf. P.Trudgill,(1974); W.Labov,(1966a); Laberge and Chiasson-Lavoie,(1971), for similar findings.

In Trifluvians' attitudes towards their own speech, the lowest-ranking group is seen to have the same percentage as that of the highest-ranking group as far as positive reactions are concerned. This finding correlates with the results of phonological variables, where manual workers and the least educated informants showed the least linguistic insecurity by often displaying the lowest degree of style shifting. Either because of a lack of awareness of linguistic features or because of an acceptance of their social status, the speakers belonging to these groups show linguistic security to a higher degree, this being demonstrated by their positive attitude towards "joual" and Trois-Rivières French as well as by the least desire to change one's language (1).

The above findings can be summarized by saying that white collar workers and informants who have had between 10 and 12 years of schooling show the greatest linguistic insecurity, and the two other occupational and educational groups the least.

Age differences.

In the data available in table 30, there were some differences by age in the respondents' reports on recognition of different accents. More of the youngest informants reported being recognized as Trifluvians through their speech and more of the informants aged between 15 to 44 recognized the existence of different "accents" between country and town and within Trois-Rivières itself.

(1) cf. W.Labov, (1966a), p.495 for similar findings.

In the questions on attitudes towards "joual" and Trois-Rivières French, the youngest informants showed the highest percentage of positive attitudes as opposed to the two other age groups. Conversely, they showed the lowest tendency to change their language and they recognized the presence of speech styles in their own speech to a greater extent.

On the other hand, the middle-aged group together with the oldest one had higher proportions of negative attitudes towards any form of speech, including their own. Older informants of the sample, therefore, appear to be the most linguistically insecure towards language.

It was stated in section 2.3.4 that Quebecers in general are trying to discover their own linguistic norm. Parisian French is rejected as the norm to adopt, but, on the other hand, people are not satisfied with their own language; both factors contribute to a degree of linguistic insecurity. With the behaviour of older informants, it can be observed that Trifluvians feel the same pressure to find a linguistic norm and that such linguistic insecurity has arisen from such pressure. As expressed by the shoemaker (inf.M.3.4), people feel that: "On parle pas bien".

The degree of linguistic insecurity greater in older informants and lower in the youngest respondents is closely related to the politico-economical situation in Québec. If section 1.1 is recalled, i.e. the section in which an overall view of French in Québec and Canada as well as of the social status of the French speaking population was described, a high correlation can be found between the linguistic insecurity observed in some groups of Trifluvians and their social

status. Given the inferiority of the socio-economic status of the average French Quebecer compared with the status of the average member of the English minority in Québec, and given the defensive position of the French language in Québec, it is not surprising that people, such as the informants concerned here, associate this negative ethnic image with their language. The social situation faced by Trifluvians is in fact the same as that found in Québec in general, since the main industries of Trois-Rivières are in the hands of the English speaking minority (cf. section 1.2.1, table 1).

What could be reported as an inferiority complex on the part of older speakers towards their language is however significantly decreasing in younger speakers. This factor is not more surprising than the linguistic insecurity found amongst older speakers. Without giving a full account of the actual political situation in Québec, it has nevertheless to be noted that there has, in recent years, been much discussion on the status of French in Québec. In recognition of the danger this language is facing, many Francophone Quebecers have demanded a reduction not only of the practical status of English in business and industry, but also an abolition of its legal status as official language in Québec (1). Through this political and cultural struggle, which has started fairly recently, strong nationalist feelings have arisen and have been mainly manifested by a no less strong identification with "joual" and the Québec French accent.

Since this demand for language survival and for political autonomy has become a major issue mainly since the 1960's, it is not surprising to find that it is the youngest

(1) By the recent Official Language Act (July 1974), French has been made the only official language in Québec. However, see section 1.1.1, p.20

informants of the sample who show the greatest degree of linguistic security, at least at a conscious level, and the highest acceptance of "joual" and of Trois-Rivières French in general.

Moreover, the above observations reveal clearly the role language plays as a reflection of society. Language, i.e. the way people use it and view it, does not only reflect the social differentiation present in an industrialized society like Trois-Rivières, but is also an accurate reflection of the divergent political and social ideologies of the same society. In Trois-Rivières, positive attitudes towards language are closely linked with the status of the speaker and how this speakers views himself, and they are moreover associated with his perception of Quebecers in general and of the status of their culture.

3.9 Summary

With this chapter, the subjective evaluation of the speech of Trois-Rivières has been concluded. The informants interviewed showed very definite attitudes towards language in general and, although expressing views in different ways, they proved the existence of a single speech community. There were, for example, members of the community who expressed negative views towards language and these could be found among all sub-groups of the sample, and the same applied for speakers who had positive attitudes. All groups were therefore seen to participate in all the range of values associated with language. Although part of the same

community, groups of speakers were nevertheless differentiated by the degree of their negative or positive attitudes. Women, older speakers and the middle-ranking occupational and educational group showed the least favourable attitudes towards the language.

The differentiations between the subjective attitudes of groups towards language were interesting not only in themselves, but also because they appeared to be in close correlation with the social differentiations found in the examination of phonological variables. Speakers appeared to react to the pressure exerted with a need for conformity with the socio-economic highest-ranking group, as demonstrated by the attitudes of white collar workers for example, as well as to the pressure to find a norm consisting of a "better" French, as shown by the percentage of speakers who felt the need to correct their language. Reaction to pressures of this sort appeared, however, to be counterbalanced by a need for conformity with a cultural tradition, due to which speakers rejected Parisian French as the norm, and also due to which speakers accepted the most extreme variety of Québec French, namely "joyal".

The description of all the values associated with native speech pattern, which are at present closely related to political ideologies, is however an unfinished task which will have to be completed in future studies.

Chapter 4

SYNTHESIS

4.0 The nature of variability

The preceding chapters of this study have been concerned with the attempt to cope with the linguistic variation present in the Trifluvian community. It was seen that each phonological feature studied offered two or several alternative forms to a speaker, and that this speaker responded to these choices by operating in terms of optionality.

The variability found for the phonological variables studied appeared to be maintained even in the most closely specified phonological and syntactic environments and to be constrained by these environments. Independently of any external factors, the application of the rules concerning usage of a back rounded half-open segment, of diphthongized vocalic elements, of opening of half-open segments, and of r-deletion were all subject to phonetic conditioning, as shown by the percentages in the incidence of the application of these rules. These phonological constraints operated to the same degree for every speaker, in that a rule applied more often in a particular environment than in another one, and this for all informants.

Although variability has been seen to be constrained by specific phonological and syntactic environments, it was in fact the case that variation was also constrained, to varying degrees, by social and stylistic factors. The fact that variable use of a given feature carried social and/or stylistic meaning was not seen in an all-or-none perspective. On the contrary, the aggregation of performance speech data in various ways revealed the existence of regularities which formed a part of the "communicative competence" of normal native speakers, although most were not categorical.

A quantitative methodology has been applied to a set of linguistic data with the aim of producing sets of rules describing competence, but involving selection of various informants speaking in a variety of social contexts. The variables studied were used in different ways with the social and stylistic structures, and with the complex processes of linguistic change.

The variables have been studied on a synchronic level and the distinctions which appeared in the use of the variables had to do mainly with the categorical v. the variable nature of the social and stylistic marking involved. Some variables appeared to be stable linguistic markers, showing both social and stylistic variations without change in "apparent time" in the age distribution, whereas other variables showed less stylistic variation, or served to mark two opposite sets of underlying social values. It therefore appeared clear that although speakers could be differentiated in one way for one particular variable, this differentiation could take another dimension for another variable, so that a different ordering of speakers occurred.

The complexity of social, stylistic, and linguistic structures appeared throughout this study, and it is not always easy to draw general conclusions on the various processes in which variables were involved. Nevertheless, agreement between the informants interviewed occurred in more than one case and thereafter regularities in speech data could be found.

As was stated often during the present investigation, the notion of "degree" was the basic assumption in the explanation of the sometimes opposite speech behaviour found. The notion of degree is most important since it constitutes the basic explanation of variability.

This approach follows Labov's proposal to incorporate systematic variation into linguistic description. Where variability is present in linguistic data, it is explained in terms of "variable rule", where the relative frequency of a rule's application can be predicted and such predicted frequency becomes an integral part of the structural description of the rule, i.e. of the linguistic competence of a speaker. A "variable rule" analysis (1) incorporates also speakers showing categorical behaviour for rules which are variable for others. Since a variable rule model deals with predicted relative frequencies in the application of a given rule, discrepancies between relative frequencies in different sub-groups of speakers will not most of the time be of the order 0 to 1, but rather in between these two extremes, so that a question of degree will represent discrepancies between these relative frequencies.

Relative differences of degree in the application of a rule very often indicate stylistic variation and socially meaningful differences between individuals or groups of individuals. These differences of degree are present in all aspects of the linguistic data where variability is present, so that a rule is seen to apply more often in a given phonological and/or syntactic environment than in another, in a specific contextual style compared with another, and finally in certain sub-groups of speakers as opposed to other sub-groups.

Given the techniques used in this investigation to discover the linguistic environments of the element in which the probability of application of a rule may be affected, and given further the elicitation of different contextual styles and the grouping of informants into various

(1) cf. H.Cedergren and D.Sankoff,(1974).

sub-groups, it has now to be seen how these various dimensions correlate with each other.

4.1 Constraints of phonological environments.

In the investigation of phonological variables, it was observed that a particular rule could apply in specific phonological environments, whereas this rule did not operate categorically in others. The notion of environment was seen to include different kinds of phonological constraints. Each of these constraints was regarded as independent, i.e. as contributing independently from other constraints to the probability of application of a given rule. Following this hypothesis, discrepancies in the application of these phonological constraints were often found.

In considering a large number of occurrences where any given rule could apply, it appeared that the various alternative realizations of a variable were not only phonologically conditioned, but that all informants showing variability in their realization of any given rule reacted in the same direction to the phonological constraints. An important agreement was therefore found amongst all informants, so that when the various variables are considered, the following evidence is provided:

1- /a/ → [ɔ]

It was seen in sections 2.2 et seq., that this rule applies in a non-final, final free, and final closed syllable.

However, for all speakers and for all contextual styles, the degree to which this rule operates is dependent on the phonological environment in which an open back unrounded /a/ is used instead of an open front unrounded /a/. Thus, the degree to which this rule operates follows the order:

$$/a/ \xrightarrow{[ɔ]} \left\{ \begin{array}{l} \text{final free syllable} \rangle \text{non-final syllable} \rangle \\ \text{final closed syllable} \end{array} \right.$$

From the data obtained, to which a quantitative methodology has been applied, it can be predicted that higher incidence of [ɔ] will be found in a final free syllable, whereas a minimum degree of application of this rule will be found when /a/ occurs in a final closed syllable.

2- V [+long] → (diphthongization)

In the study of diphthongized vocalic segments, it was seen that realization of a long vocalic element as a diphthong was subject to many factors. The two vowels /ɛ/ and /a/ were seen to be liable to become diphthongized before any final consonant, so that /ɛ/, /a/ → ⟨[ɛ^ɪ: - a^ʊ:]⟩ / -C₁ †. On the other hand the two other half-open segments /œ/ and /ɔ/ were found to be diphthongized only when followed by /r/. Thus, /œ/, /ɔ/ → ⟨[œ^ʏ: - ɔ^ʊ:]⟩ / -r †.

In addition, the degree to which these vowels were diphthongized appeared always in the order: /ɛ/ > /a/ - /ɛ - œ/ + r > /ɔ/ + r, implying that /ɛ/, long historically, is the vocalic element in which the most frequent occurrences of diphthongs can be predicted, /ɔ/ is the element where less diphthongs are to be expected, whereas for /a/, /ɛ/ and /œ/ + r, a similar degree of diphthongization will be found.

3- /ε - œ - ɔ / → ⟨[ɛ: ʌ: ɔ:]⟩ / -r †

The opening of half-open segments was seen to take place only when these vocalic elements were followed by /r/. Each segment was involved in linguistic change, and opening of /œ/ into [ʌ:] was seen to be at the earliest stage of the process, by being realized at the lowest level by all informants.

4- /r/ → ∅ / - $\left. \begin{array}{l} C(r)w \\ V(r)C (\ddagger) \\ V(r)\ddagger \\ V(r)\ddagger \ddagger C \\ C(r)\ddagger \end{array} \right\}$

r-deletion can occur only in these phonological environments. Variability occurred in r-deletion for all of these environments. However, the degree to which /r/ was deleted by all informants was the greatest in the environment -C(r)†, and the lowest in the environment -V(r)C (‡), whereas for the remaining phonological environments, /r/ was deleted to nearly the same extent, thus giving the following ordering:

/r/ → ∅ / -C(r)† > C(r)w, V(r)†, V(r)† †C > V(r)C

The rules which have been given here are not simply summaries of the performance data of particular sub-groups of the Trifluvian community. They are general constraints reflecting the linguistic system of this speech community. These constraints influence the degree to which rules will apply and each of them is equally important in accounting for variability in their realizations.

Although phonological environments operate as constraints in the application of a rule, it is, in addition, the

case that variability in rules is also constrained, to varying degrees, by stylistic and social factors. In order to emphasize the importance of each of these two latter factors, these will be examined separately for each variable rule concerned in this study.

4.2 The structure of stylistic variation

In the study of phonological variables of Trois-Rivières French, the purpose was to isolate different contextual speech styles in highly comparable interview situations with various informants, so as to discover regular patterns of behaviour governing the use of phonological variables in the speech of these informants.

The dimensions of stylistic variation do not usually indicate that phonological variables are composed of discrete units which alternate in an all-or-none relationship. On the contrary, the speech styles are rather viewed as a continuum, i.e. as illustrating situations in which a speaker passes from careful to increasingly more casual speech, according to the situation and the topic, the listener remaining a constant factor in the interview situation. The contrasts between speech styles are generally underlined by the value each phonological variable has in each contextual style. These variables do not operate in an all-or-none relationship but rather in terms of differences in their frequencies of occurrence. Thus, it is the frequency of occurrence of a variable in a given style contrasting with another frequency of occurrence of this same variable in another style which takes stylistic significance.

Evidence from the present study shows that contextual constraints are apparent in shifting pronunciation patterns of speakers.

However, when a speaker is required to pronounce a single word in isolation from any real verbal context, it is possible that he may elicit more affected pronunciations. Such a case happened in what has been called "careful style" in this study. Whatever limitation such contextual style may have, however, it was seen that all speakers reacted in the same way towards this style by showing similar patterns of style shifts. Moreover, this style seems to have served as an important means of eliciting a formal setting. In this formal verbal situation, the pressure to adopt the prestige speech forms appeared clearly.

When moving to more careful speech styles, it is in fact the social value attached to a variable which appears. Speakers use a variable at a certain level in more casual speech. If this variable has social significance, the value attributed to it will appear in careful speech styles, in which the attention of a speaker will be to reproduce as much as he can of the prestige form of speech, i.e. to realize the social value he gives to a variable.

The styles of speech elicited in this study are organized along a single dimension according to the amount of attention paid to speech. Usually, most speakers follow a regular pattern of style shifting in the same direction, but higher or lower degrees of style shifts in the absolute values of a variable according to awareness and self-control are also present. In fact, all speakers do not react to the same degree to the pressure to use a prestige form in more formal speech situations.

Taking into account the techniques used for isolating contextual styles within the interview situation, it should now be seen how the stylistic dimension correlates with the phonological variables. For this purpose, the phonological variables may be ordered in the following way:

	<u>RS</u>		<u>CS</u>		<u>FC</u>
1- /a/ → ⟨[ɔ]⟩	X	<	X	<	X
2- Archaic features			X	<	X
3- /r/ → ⟨∅⟩	X	=	X	<	X
4- /ɛ/ → ⟨[ɛ̃:]⟩ higher ranking- status groups	X	<	X	<	X
5- /œ/ → ⟨[ʌ:]⟩	X	<	X	<	X
6- /ɛ/ → ⟨[ɛ̃:]⟩ lower ranking- status group	X	<	X	>	X
7- /ɔ/ → ⟨[ɔ̃:]⟩	—		X	>	X
8- V [+long] → ⟨diphthongization⟩	X	<	X	>	X

These relationships demonstrate the degree to which each variable was used in different contextual styles. Although some variations from these generalizations were found in the detailed description of each variable, the type of ordering exhibited above nevertheless reflects the general style shifts of all informants.

For the first five variables, all informants apply the variable rules the least often in reading style, with thereafter a regular increase in their application obtaining a maximum application in formal conversation. The last three

variables show that all speakers responded to the rules to a maximum degree in careful style, whereas the use of these rules decreased in formal conversation and reading style.

The absolute values of the variables do not appear in this ordering of speech styles, but it is nevertheless obvious that the structure of stylistic variation is essentially the same for all informants interviewed. In this comparison of speech styles, it appears that Trois-Rivières is a speech community, which shares a common evaluation of the same variables. These variables serve of course to differentiate groups of speakers, in that the degree to which each group will use a variable will be different. However, the structures of stylistic variation seen above demonstrate the concrete existence of a common set of evaluative values. They moreover demonstrate that individuals possess a "speech repertoire" (1) from which they can operate in terms of degree in the selection of speech forms according to the nature of situational constraints. An important aspect which is derived from the observation of regular patterns of style shifting is that of "accent mobility", or of the individuals' ability to modify their pronunciation according to the situation and topic.

Thus, it can be assumed that all individuals are able, however slightly, to modify their speech, by decreasing or increasing their use of certain linguistic features according to the social value attributed to these features and according to the formality or non-formality of the situation faced.

(1) For the notion of "speech repertoire" see: Giles, (1973); J.J.Gumperz, (1964a); Ervin-Tripp, (1964).

However, there is a second dimension of linguistic variation, which appears in the differentiation of speakers by their social characteristics, i.e. the dimension of social variation.

4.3 Social structure

As was seen in section 4.2 on stylistic structure, the Trifluvian informants show a remarkable agreement in the patterns of stylistic variation. To study social variation, it was necessary to isolate different contextual styles since the context of a formal interview does not elicit casual speech. The success of the elicitation of a somewhat normal conversation is to be seen in the patterns of style shifts which were found.

Although agreement in the patterns of stylistic variation between all informants has been found, the style shifts might be more or less important according to the group of speakers concerned. This is where social variation comes into play. It is the different value each group gives to a variable in the same contextual style which indicates social differentiation.

Where individuals or groups of individuals are concerned, it is the objective social and economic indicators giving approximate cues as to the position of these individuals which constitute the basic means of correlation with the observation of language used in everyday social interaction. Since important factors such as relations of superior-inferior between two speakers, the degree of authority, intimacy, etc.

cannot be accounted for by well-developed measures in a formal interview, it seems important to connect the linguistic behaviour observed with objective indicators such as education, occupation, sex, etc. From such a correlation, the way in which an individual presents himself in some social settings will become apparent, and general information about the way his status is reflected through his language will be provided.

Not all of the linguistic material carries social meaning. However, with those elements of language carrying such meaning, the question of linguistic change arises immediately. Since language is here correlated with the status of individuals, changes in language can be correlated either with real changes in the social position of a sub-group or with changes in an individual's identification with a particular sub-group. As Labov writes:

"Current evidence shows that most incoming changes follow significant social distributions before they register any stylistic shifting" (1).

Where there is social and/or stylistic variation present amongst groups of speakers, it usually indicates a change in the social value attributed to a given variable. This change can sometimes be seen in the different value each generation of a speech community may give to a variable. However, changes are not always observable in "apparent time" and it is often through the mere existence of variable behaviour towards a linguistic feature that linguistic change will be indicated.

From the various types of variables which can be encountered in a linguistic study, Labov has defined three

(1) W.Labov, (1972b), p.284

main categories of variables which account for the different social and stylistic distributions of these variables.

"Indicators", "markers", and "stereotypes" (1) offer different types of distribution, but all of them have social significance. In order to summarize the finding of the preceding chapters, the differentiations found between groups of speakers for the various variables will be considered again.

A- Stereotypes

A linguistic stereotype is a social fact since it has risen to social consciousness. It can be subject to overt comment and it is often referred to when language is the topic of a discussion. The linguistic features labelled as "stereotypes" in this study concern the use of archaic phonetic features. As was seen in section 2.3.2 and in chapter 3, there is a variety of social values associated with such stereotypes. Some of these features are heavily stigmatized, such as the use of moé, toé, etc., but are nevertheless resistant, as the behaviour of lower-ranking groups showed. Others have varying degrees of prestige, such as [h] or [x] instead of /ʒ/ and /ʃ/, considered as features of mens' speech, whereas others might carry more positive values, such as the opening of /ɛ/ into [æ] present in the speech of higher-ranking status groups.

Social stigmatization of some stereotypes has led to a more rapid linguistic change, in that almost complete disappearance of the features can be observed. Examples of such change can be seen in the features [h], [x], and [œ:] (cf. table 13, section 2.3.3.1).

(1) W.Labov, (1970), p.205

However, all cases of stigmatized linguistic features in Trois-Rivières French have demonstrated the existence of two different sets of linguistic behaviour. Higher educational and occupational groups show presence of any of the stereotypes at a very low level, and, usually, these are absent in the speech of these groups in the context of the interview situation. On the contrary, most of these features are present to a high degree in the most informal speech style of the lowest occupational and educational groups.

These linguistic stereotypes are the features through which the most important occupational and educational differences were found. They constitute linguistic features consciously rejected by higher-ranking status groups, and this rejection leads to strong pressure from above for lower-ranking groups to conform to this social evaluation. These latter respond strongly to this overt pressure from above by displaying very important style shifts. Their pattern of behaviour in more formal speech styles is sometimes the opposite of that in formal conversation. The linguistic stereotypes studied constitute an accurate reflection of social indices. They represent an example where social status and social values strongly correlate with linguistic behaviour.

Another interesting factor which can arise from a change in the value attributed to some linguistic features is that of linguistic change leading to new pronunciations of the phonemes under overt social comment. Such case can be seen in the linguistic change affecting the long vocalic element /ɛ/.

B- Markers

As was reported in section 2.3.2, linguistic markers show both social and stylistic variation. The opening of the half-open front unrounded /ɛ/ before /r/ is probably offering a case of a new linguistic marker. The phenomenon of opening this vocalic segment is probably due to the presence of a following /r/, as the same is true for the two other half-open vowels, i.e. /œ/ and /ɔ/. However, the social and stylistic variations present in the case of /ɛ/ demonstrate that there is more in the explanation of this change than the mere presence of a following consonant.

It was in fact seen that /ɛ/ + r can be realized as a half-close vowel, i.e. [e:] . This latter pronunciation constitutes a linguistic stereotype and is strongly correlated with uneducated and lower class speech. This fact is confirmed by the behaviour of groups of speakers towards this form of speech (cf. table 13, section 2.3.3.1) . The rejection of this archaic speech form has led to a linguistic change, namely the opening of /ɛ/ + r into [ɛ:]. In this change, young speakers of higher-ranking status groups are the leaders and they are followed by older members of their group.

There are two pressures from above present for the same variable:

- 1- rejection of [e:] as a realization of /ɛ/ + r by higher-ranking groups;
- 2- adoption of a new form by these same groups, i.e. opening of the phoneme into [ɛ:].

Lower-ranking status groups react to both pressures accordingly. They first reduce considerably their usage of [e:] in more

formal speech styles and conversely increase their use of [ɛ:] in the same contextual styles. However, the informants of this latter group are not affected to the same degree by these pressures from above, since it was observed that men, and especially older ones, reacted most strongly to these in showing the highest degree of style shifting.

Thus, the above factors demonstrate that a linguistic change may originate from a socially rejected speech form, in which the stylistic and social stratifications present in the newly adopted form, here [ɛ:], constitute a linguistic marker.

Cases of linguistic markers have also been most consistently represented in the case of variable (a)-l and of r-deletion.

There has been a tendency historically in French towards usage of a back rounded [ɔ] instead of [ɑ], and towards loss of /r/ in a number of environments. It appears clearly that the rule /ɑ/ → [ɔ], in formal conversation, has reached completion when this vocalic element is found in a final free and non-final syllable, and that the minority of speakers who do not use [ɔ] at a 100% level in these two environments may result from a long-standing hypercorrective tendency. This tendency to correct too high a usage of [ɔ] is seen in the very important style shifts in higher-ranking groups. It is obvious that the social value attributed to the half-open back rounded variety has drastically changed.

A similar situation occurs with r-deletion, although variability is present in all phonological environments, i.e. r-deletion is never maintained at a 100% level.

As Labov states: "Innovation by the highest-status group is normally a form of borrowing from outside sources, more or less conscious; with some exceptions, these will be prestige forms" (1). Wider usage of the open back unrounded variety [ɑ] and of r-pronunciation observed in more careful speech styles has most probably been modelled on the Parisian French influence. These changes from above are quite regular. They have in fact affected each sub-group of the speech community in proportion to its distance from the originating group which spread the prestige forms, and in proportion to the formality of the situation. The patterns of style shifts observed in variable (a)-1 and r-deletion show the way in which the prestige forms have affected speakers in the most formal styles. In addition, it was seen that the highest educational and occupational groups, women, and younger speakers for variable (a)-1 were the most affected groups, i.e. showing the highest degree of style shifting.

For some phonological environments of these two variables, the second-highest educational and occupational group showed patterns of hypercorrection by nearing the behaviour of the lowest-ranking group in formal conversation and by approaching that of the highest-ranking group in more formal speech contexts. This phenomenon shows linguistic insecurity on the part of these speakers and constitutes an "important element in the mechanism of linguistic change" (2).

These two variables offer cases where social differentiation is present in the social value attributed to them. In both cases, styles of speech are important factors in accounting for the frequencies of operation of the rules. In addition, occupation and education constitute the most

(1) W.Labov, (1972b), p.290

(2) Id., p.291

significant social parameters in explaining discrepancies between groups of speakers.

Women are also seen to play a part in that they are more sensitive to prestige forms than men. However, these two variables do not show regular distribution in "apparent time", since there are no important age differentiations present, especially in formal conversation. This is probably due to the fact that variable (a)-l and r-deletion constitute stable linguistic markers, in which stylistic variation is directly parallel to indices of social characteristics. In such cases, there is a regular stylistic and social stratification which are clear indicators of the social status of a speaker and of the social context in which he is speaking. Moreover, women are usually seen to be more sensitive than men to the prestige patterns (1). These patterns of behaviour given by stable linguistic markers can be maintained over long periods of time, and are not, very often, involved in age differentiation.

C- Indicators

On the other hand, the phenomenon of diphthongization of long vocalic segments appears to be an indicator of age and social differentiation. There has also been a tendency historically in Québec French towards diphthongization of long vowels, as was the case for variable (a)-l and r-deletion. However, these latter phonological variables were not so involved in a process of linguistic change, since no age differentiation appeared in the style approaching everyday speech. On the other hand, they appeared to be involved

(1) cf. W.Labov,(1966a); P.Trudgill,(1974), for similar findings.

in stable stylistic and social stratifications. However, diphthongization is involved in such linguistic change, as younger speakers showed a decrease in the incidence of this phenomenon, especially in formal conversation, and moreover, diphthongization shows a regular social stratification.

Thus, at present, this linguistic phenomenon seems to be an indicator of age and social status. If diphthongization was a linguistic "marker", it would have acquired more systematic social value, and would have been corrected in formal speech. The opposite situation occurs in that incidence of diphthongization increases in careful style, which is the opposite of the patterns of variable (a)-l and r-deletion. Moreover, it was observed in the two latter cases that women showed more awareness of social norms of speech than men, this being observed in their greater style shifts. For diphthongization, however, the patterns of behaviour of women demonstrate that this variable has not yet reached an important degree of social consciousness; in fact, in formal conversation, it can be observed that women tend to use higher percentages of diphthongized vocalic segments than men. The lack of a corrective tendency in formal styles indicates that diphthongization of long vocalic elements is at present an indicator of age and social status not yet involved in systematic stylistic variation.

D- Linguistic change without social meaning.

Other main sound changes observed in progress concerned variable (r)-l and the opening of two half-open segments, namely /œ/ and /ɔ /.

The sound change indicated in the use of a uvular trill from an alveolar one has shown that this change is beginning in the oldest generation, that it is variable in the middle age group, and almost completed in the youngest generation. There are no social nor stylistic variations present, and this change through "random drift" is mostly represented in the youngest speakers and in women.

However, the changes affecting /œ/ and /ɔ/ +r appeared to be variable in all three generations considered. They are not involved in social stratification, as for variable (r)-l, and are also mostly represented in younger speakers and in women. However, there is stylistic variation present, especially in the opening of /ɔ/ + r into [ɔ:]. The corrective tendency to increase [ɔ:] in formal speech observed in all groups is not due to social pressures, but rather to pressures between phonemes and thereafter to hypercorrection.

At present, the linguistic changes affecting /œ/ and /ɔ/ + r are represented in all sub-groups of the Trifluvian community and all of them react in a uniform manner to the new varieties. Whether or not these new values, i.e. [A:] and [ɔ:], will become a prestige model and show social and stylistic variations at later stages is hard to establish. However, these changes offer interesting prospects for further investigations, since they most probably are at a very early stage of their evolution.

In summary, the full set of phonetic realization rules of variables for the Trifluvian informants interviewed is as follows:

$$1- /a/ \rightarrow \langle [A-a-v-ɔ] \rangle \left/ \begin{array}{l} \text{final free syllable} \\ \text{non-final syllable} \\ \text{final closed syllable} \end{array} \right\}$$

f (phonological environment, style, education and occupation, sex, age)

2- /ɛ/ → ⟨[ɛ - æ]⟩ / - {^{r+C}#} /
 f (education and occupation, style)

3- /wa/ → ⟨[wa: - wɛ:]⟩ / - r# /
 f (education and occupation, style)

4- /wa/ → ⟨[wa - wɛ]⟩ / - # /
 f (education and occupation, style)

5- /ɜ-ʃ/ → ⟨[ɜ-h] [-x]⟩ / {^{#(ɜ-ʃ)-}_{v(ɜ-ʃ)v}} /
 f (education and occupation, style, sex, age)

6- /œ/ → ⟨[œ: - œ:]⟩ / - r# /
 f (education and occupation, style, sex, age)

7- /ɛ/ → ⟨[ɛ: - ɛ:]⟩ / - r# /
 f (education and occupation, style, sex)

8- V[+long] → ⟨diphthongization⟩ /
 f (phonological environment, education, occupation, sex, age, style)

9- /ɛ/ → ⟨[ɛ: - ɛ:]⟩ / - r# /
 f (style, age, education and occupation, sex)

10- /ɔ/ → ⟨[ɔ: - ɔ:]⟩ / - r# /
 f (style, age, sex)

11- /œ/ → ⟨[œ: - ʌ:]⟩ / - r# /
 f (age, education, style)

12- /r/ \longrightarrow $\langle [r - R] \rangle$
 f (age, sex)

13- /r/ \longrightarrow $\langle [r - R] - \emptyset \rangle$ / $\left\{ \begin{array}{l} C(r)w \\ V(r)C (\#) \\ -V(r)\# \\ -V(r)\#\#C \\ -C(r)\# \end{array} \right\}$

f (phonological environment, education and
 occupation, style, sex)

CONCLUSION

The systematic quantitative study of variation has provided for the conclusion that members of a speech community are aware of the commonness, rarity, novelty, etc., of many features of speech, and that this knowledge enters into their evaluations of ways of speaking.

Although social meanings may be encountered in many areas of the linguistic system, they require the existence of more than one equivalent synonym to carry social information. It is the speaker's selection among these variable elements of language which carry social meaning; when speakers are subdivided into groups, it often appears that these show different mean scores in the selection of variable elements of the language. However, this fact does not mean that many "dialects" or "codes" are necessarily considered; on the contrary, the differences between groups of speakers imply most of the time, that a particular variable feature is a tendency of men, or of younger speakers, or of lower-ranking status groups, etc. As Fishman writes:

"In a relatively open and fluid society... we find not a clearcut cleavage between the social classes, but a difference in rate of realization of particular variants of particular variables for particular contexts" (1).

These differences of degree in the realization of variable rules nevertheless indicate the magnitude of accent mobility of each sub-group of the community, and give good indications of the range of values present for particular

(1) J.A.Fishman, (1972a), p.83

variables. They serve to emphasize the role of linguistic variation as a mirror of social variation, which itself plays an important part in the mechanism of linguistic evolution.

The remarks in the sections of this work on the role women, young speakers, and each sub-group of the informants interviewed play in variable aspects of the linguistic system constitute further justification for theoretical approaches such as those represented by Labov, Gumperz, etc.

However, there are many unfinished tasks which will have to be carried out in further investigations. In Trois-Rivières, as in Québec in general, it has been seen that a complex set of political ideas concerning the future of French in this part of America are at present in conflict. From the observation of phonological variables, it could be seen that there are tendencies to borrow aspects of Standard French in formal speech and to reject features characteristic of general Québec French. In addition, a deep need to find a linguistic norm has been apparent throughout this study. An interesting aspect which could form one of the basic assumption of a future study would be to consider not only objective scalings, such as age, sex, etc., but also political, social, etc., ideologies of speakers.

Other phenomena, such as topic, listener, setting, peer group membership, etc. have already been considered in many works and have proved to be important aspects to account for linguistic variations in a community. The ideologies mentioned above, i.e. how people view their society, its future, the relations between its members, etc. could very well add new dimensions to the conclusions drawn on the correlation between subjective attitudes and objective linguistic behaviour. This is only one of the many aspects which might be investigated in future studies.

APPENDIX

The Questionnaire

Nom:

Prénom:

Sexe:

Né(e) à:

le:

Père né à:

Mère née à:

Grand-père paternel né à:

Grand-mère paternelle née à:

Grand-père maternel né à:

Grand-mère maternelle née à:

Epoux (se) né à:

Nombre d'enfants:

leur âge:

Le sujet a fréquenté l'école pendant:

jusqu'à l'âge de:

Adresse:

Profession:

Numéro code:

- Est-ce que vous avez toujours habité ici?
- (si non) Depuis combien de temps habitez-vous ici?
- (si non) Dans quelle autre ville du Québec avez-vous habité?
- Combien de temps?
- Dans quelle ville travaillez-vous?
- Connaissez-vous une autre langue que le français?
- (si oui) a- un peu
 b- assez bien
 c- très bien
- Est-ce que le français est votre langue de travail?
- Faites-vous des voyages pendant l'année?
- (si oui) a- combien ?
 b- où allez-vous en général ?
 c- combien de temps partez-vous ?
- Où avez-vous fait votre école primaire?
 votre secondaire?
 votre collégial?
 votre université?

Part 11

- | | |
|--|-------------|
| 1. Le chiffre après 2 est... | trois |
| 2. Le chiffre après 3 est... | quatre |
| 3. Quatre + trois font... | sept |
| 4. Le chiffre après huit est... | neuf |
| 5. Celui après treize est... | quatorze |
| 6. Quinze + 1 est égal à... | seize |
| 7. Le chiffre après cinquante-neuf est... | soixante |
| 8. Avec des chiffres, on peut diviser, multiplier, additionner et... | soustraire |
| 9. Dans une rangée, la personne qui a le numéro deux est la deuxième. Comment appelle-t-on celle qui a le numéro un... | la première |
| 10. Celle qui a le numéro sept ... | la septième |
| 11. Celle qui a le numéro neuf... | la neuvième |
| 12. Celle qui a le dernier numéro | la dernière |
| 13. L'année est divisée en douze... | mois |
| 14. Le premier mois de l'année est le mois de... | janvier |
| 15. Le mois qui vient après février est... | mars |
| 16. Ensuite c'est le mois ... | d'avril |
| 17. Après mai, vient le mois de ... | juin |
| 18. Et ensuite, c'est le mois de... | juillet |
| 19. Après septembre c'est le mois ... | d'octobre |
| 20. Et ensuite... | novembre |

- | | |
|--|--------------|
| 21. Quelle saison commence à la fin de septembre... | l'automne |
| 22. Quelle saison commence à la fin de décembre... | l'hiver |
| 23. L'année est divisée en 52... | semaines |
| 24. Dans une semaine, il y a sept... | jours |
| 25. Le premier jour de la semaine est... | dimanche |
| 26. Après lundi, c'est... | mardi |
| 27. et ensuite vient... | mercredi |
| 28. Dans une journée, il y a le matin, le midi et ensuite... | l'après-midi |
| 29. A partir de six heures environ, c'est le... | soir |
| 30. Il y a soixante secondes dans une minute et soixante minutes dans une... | heure |
| 31. Quel repas prenez-vous le matin... | le déjeuner |
| 32. Demain, c'est (ex.mercredi): alors mardi, c'est... | aujourd'hui |
| 33. Lundi, c'était... | hier |
| (en pointant avec le doigt) | |
| 34. c'est mon... | corps |
| 35. c'est ma... | tête |
| 36. ce sont mes... | cheveux |
| 37. c'est ma... | bouche |
| 38. | oreilles |
| 39. | joue |
| 40. | oeil |
| 41. | mâchoire |
| 42. | gorge |

43.	bras
44.	poignet
45.	doigts
46.	taille
47.	hanches
48.	jambes
49.	cheville
50.	orteils
51.	genou
52. Quand vous avez faim qu'est-ce que vous faites...	je mange
53. Quand vous avez soif...	je bois
54. Quand vous avez bien mangé, vous dites que vous avez pris un bon	repas
55. Les enfants boivent beaucoup d'un liquide blanc. C'est du...	lait
56. On boit généralement du lait dans un...	verre
57. Et du café dans une ...	tasse
58. Pour faire du café, on a besoin de café et d'eau... a- l'opposé de l'adjectif froid est...(chaud)	chaude
59. On fait bouillir de l'eau dans une...	bouilloire
60. Pour faire une tarte, il faut d'abord préparer de la...	pâte
61. Dans un oeuf, il y a le blanc et le...	jaune
62. On mange de la soupe avec une...	cuillère
63. Pour manger de la viande, il faut un couteau et une...	fourchette
64. On peut faire pousser nos propres légumes dans un...	jardin

65. Quand c'est l'anniversaire de quelqu'un,
on fait une certaine pâtisserie sur la-
quelle on met du glaçage et des chandelles,
c'est un... gâteau
66. Celui qui coupe la viande et la vend est un...boucher
67. Qu'est-ce qu'on met généralement sur son pain..du beurre
68. Avec du lait, on fait du beurre et aussi de la crème
69. Du Kraft, c'est une sorte de... fromage
70. Quand on achète du pain, on ne veut pas
du pain moisi, mais du pain... frais
71. Comment appelle-t-on celui qui fait du pain...boulangier
72. Le 25 décembre, tout le monde se souhaite un..joyeux Noël
73. Noël, le Jour de l'An, les Rois, c'est
le temps des... fêtes
74. Avant, il fallait jeûner 40 jours avant
Pâques. C'était le... carême
75. Comment appelle-t-on le moment où Jésus
était rassemblé avec ses apôtres pour leur
dernier repas: la dernière... scène
76. Quel est l'objet qu'on accroche au mur
pour pouvoir dire l'heure... une horloge
77. L'hiver, il ne pleut pas, il... neige
78. L'hiver, il ne fait pas chaud, il fait... froid
79. Si on n'habite pas dans un appartement, on
habite dans une... maison
80. Pour sortir de la maison, il faut ouvrir la...porte
81. Pour regarder dehors, on regarde par la... fenêtre
82. S'il y a des courants d'air dans la maison,
c'est souvent parce que la porte est restée...ouverte
83. Si la porte est ouverte,vous allez la... fermée
84. Quand on fait un feu dans la maison, on
fait un feu dans un... foyer

85. Pour faire un feu de foyer, on fait brûler du... bois
86. La fumée sort par la... cheminée
87. La pièce dans laquelle on se couche est une... chambre
88. Vous êtes assis sur une... chaise
89. Pour aller au deuxième étage d'une maison,
il faut monter un... escalier
90. L'été, les feuilles sont de quelle couleur... vertes
91. Et l'automne... rouges
92. Rouge, bleu, vert, etc. sont des couleurs
93. Ce qui couvre la maison pour empêcher la pluie
de nous tomber sur la tête, c'est un... toit
94. Vous mettez votre voiture dans un... garage
a- On fait réparer son auto dans un...
95. Quand le linge est sale, il faut faire le... lavage
96. Quand le linge est froissé, il faut faire le... repassage
97. Pour se laver on peut prendre un bain ou une... douche
98. Après un bain, on s'essuit avec une... serviette
99. On balaye avec un... balai
100. Les saveurs les plus connues de crème glacée
sont: fraise, vanille et... chocolat
101. Les roses, les tulipes, les violettes sont des... fleurs
102. La bière et les liqueurs douces sont souvent
dans des contenants en verre qu'on appelle des... bouteilles
103. Quel animal est semblable à une souris, mais
plus gros... un rat
104. Un animal qui miaule est... un chat
105. Un animal qui aboie est un... chien
106. Un animal qui hennit est... un cheval
107. Un animal qui donne du lait est une... vache

108. Les poules sont gardées dans un.. poulailler
109. Une vache qui a ses veaux, on dit qu'elle... vèle
110. Un chien n'a qu'un seul... maître
111. Comment appelle-t-on l'animal plus petit qu'un cheval et qui fait hi-han... un âne
112. Quel animal coupe le bois avec ses dents et fait des barrages... le castor
113. On fait pousser du foin dans un... champ
114. Comment s'appelle le poil des moutons avec lequel on fait des chandails... laine
115. Sur la ferme, la bâtisse où l'on range le foin est une... grange
116. Les insectes qui font du miel sont des... abeilles
117. Une femme qui a des enfants est une... mère
118. Un homme qui a des enfants est un... père
119. Une femme dont le mari est mort est une... veuve
120. Votre enfant de sexe féminin est votre... fille
121. Dans la même famille, un garçon et une fille sont... frère et soeur
122. Quand vous êtes effrayés, vous tremblez de... peur
123. Si vous voulez savoir si quelqu'un est jeune ou non, vous lui demandez son.. âge
124. Le Christ est mort sur une... croix
125. Si un homme peut lever un poids de 200 livres, il n'est pas faible, il est... fort
126. Si vous ne voulez pas être pied nu, vous mettez des souliers et avant des... bas
127. Si quelqu'un ne peut pas parler, il est... muet
128. Si quelqu'un semble joyeux et rit, on dit qu'il est de bonne... humeur

129. Pour apprendre à lire et à écrire, les enfants vont à l'école
130. On va voir des films au... cinéma
131. Un chanteur professionnel doit avoir une belle... voix
132. Pour enlever la poussière d'un manteau, on prend une... brosse
a- on se peigne avec un peigne ou avec une...
133. Quand un objet coûte beaucoup d'argent, on dit que ça coûte... cher
134. Si on joue à un jeu, on ne veut pas perdre, on veut... gagner
135. L'opposé de l'adjectif bon est... mauvais
136. Si un ami essaie quelque chose de nouveau, on lui souhaite... bonne chance
137. Un canadien est un citoyen du... Canada
138. L'opposé de l'adverbe ici est (geste)... là
139. Pour monter sur le toit d'une maison, il faut prendre une... échelle
140. A la fin de la vie, vient la... mort
141. L'organe qui pompe notre sang est le... coeur
142. On coud avec du fil et une aiguille
143. Dow, O'Keefe, Labatt, ce sont des marques de... bière
144. Quand quelqu'un ronfle, est-ce qu'il est réveillé?... non, il dort
145. Quand on pense en dormant, on... rêve
146. Dans un livre, il y a par exemple 150... pages
147. 8 heures du matin, c'est tôt; 11 heures du soir c'est... tard
148. Les quatre points cardinaux sont: le sud, l'est, l'ouest et le... nord
149. Le contraire du mot guerre est le mot... paix

150. Les indiens appelaient les hommes blancs, les visages...
a- l'opposé de l'adjectif foncé est... pâles
151. Quand quelqu'un marche en rond, on dit qu'il fait les cent... pas
152. Pendant le jour, quand on ne voit pas le soleil, c'est parce qu'il y a des... nuages
153. On peut dire que quelqu'un a du chagrin ou qu'il a de la... peine
154. Pouvez-vous me donner la première personne du singulier du verbe graisser... je graisse
155. du verbe gagner... je gagne
156. du verbe réclamer... je réclame
157. et du verbe condamner... je condamne
158. Sur du papier, on écrit avec un crayon et sur un tableau noir, on écrit avec une... craie
159. Pour attendre le train, on va à la... gare
160. Pour ne pas qu'un oiseau s'envole, on le met en cage
161. Le contraire de l'adjectif vieux est... jeune
162. L'opposé du mot vieillesse est le mot... jeunesse
163. Dans les films policiers, les films de cow-boy, il y a toujours les bons et les... méchants
164. Les feuilles d'un arbre sont pendues après les..branches
165. Pour qu'un enfant s'endorme, on peut le... bercer
166. l'arbre qui donne des glands est un... chêne
a- On attache un animal avec une corde ou avec quelque chose de plus solide, en fer, c'est une ... (chaine)
167. Celui qui ment est un... menteur
168. L'endroit où les animaux vont s'abreuver, est un..abreuvoir
169. La première personne du singulier du verbe cueillir est... je cueille

170. De quel instrument se sert-on pour couper du bois.. une hache
171. La Propagation de la Foi, la St-Vincent de Paul, ce sont des bonnes... oeuvres
172. L'homme qui a une ferme et qui cultive la terre est un... cultivateur
173. Quelqu'un qui est millionnaire a beaucoup... d'argent
174. Dans un jeu de cartes, les quatre cartes qui ont le plus de valeur après les rois sont les... as
175. Pour gagner sa vie, il faut ... travailler
176. Celui qui a pour emploi de balayer est un... balayeur
177. Le contraire de l'adjectif faux est... vrai
178. Quand la marée du fleuve n'est pas haute, elle est... basse
179. Quand vous vous endormez, qu'est-ce que vous faites (geste) je baille
180. On ne dit pas: une nappe blanc, mais une nappe... blanche
181. On ne dit pas d'une pomme qu'elle est bon, mais qu'elle est... bonne
182. Qu'est-ce qu'on met sur une bouteille pour la fermer... un bouchon
183. Quel est le nom du bijou que les femmes portent au poignet... un bracelet
184. Quelle est la partie du pantalon dans laquelle on met son argent... la poche
185. On allume une cigarette avec une allumette ou un... briquet
186. Quand un enfant trouve un bon endroit pour ne pas qu'on le trouve, on dit qu'il a trouvé une bonne... cachette
187. Il y a 12 pouces dans un pied, et 36 pouces dans... une verge
188. Quelqu'un qui chante est un... chanteur
189. Quand on dit un rosaire, on dit trois... chapelets
190. Le féminin de l'adjectif franc est... franche

191. L'homme est composé d'un corps et d'une... âme
192. Qu'est-ce qu'un roi porte sur la tête... une couronne
193. Une table, une chaise, un bureau, ce sont des... meubles
194. Comment appelle-t-on un petit morceau de bois qui entre sous la peau... une écharde
195. Quel est le nom de la substance qui recouvre un arbre... l'écorce
196. Comment appelle-t-on l'astre qu'on voit pendant le jour... le soleil
197. Le St-Maurice est une rivière, le St-Laurent est un... fleuve
198. On ne dit pas la bouche d'un animal mais sa... gueule
199. Quand on mesure un objet, on mesure la longueur, la hauteur et la... largeur
200. Qu'est-ce qu'on utilise pour se moucher... un mouchoir

Proverbes

201. Corrigez: virer son capot de côté... de bord
202. Corrigez: il fait clair comme chez le diable.... noir
203. Pour dire que quelqu'un est de mauvaise humeur, on dit qu'il a mangé de la vache... enragée
204. Complétez: qui veut la fin, prend les... moyens
205. Pour dire qu'on ne doit pas se fier aux apparences, on dit: l'habit ne fait pas le... moine
206. Pour dire que quelqu'un va trop vite, on dit qu'il prend le aux dents. mords

Part III: Reading passage

Pouvez-vous lire ce texte. Je vais ensuite vous demander de raconter l'histoire dans vos propres mots:

- Tard, vers la fin du jour, ma jeune soeur lisait à la lueur d'une lampe, lorsqu'elle entendit un renard marcher près de la maison. Elle le voit piétiner les fleurs rouges du jardin, passer derrière la clôture de broche du poulailler. Le rôdeur regarde sous la porte. S'appuyant au cadre, il pousse la porte et l'ouvre. Comme mon père était parti chez le boulanger, ma soeur s'en va à la grange, décroche une carabine et s'approche du poulailler. Elle monte sur la butte en face de la fenêtre, vise le renard et tire. La balle le frappe à la tête. Il hurle et s'effondre sur le sol. Le hurlement d'horreur m'éveilla brusquement. Ce fut le pire rêve de ma vie.

Pouvez-vous maintenant me raconter cette histoire dans vos propres mots.

Part 1V

1. Si vous gagniez le \$125,000 de la Loto-Québec, que feriez-vous avec cet argent?
2. Avez-vous déjà failli mourir dans un accident par exemple? Pouvez-vous raconter?
ou
avez-vous déjà été témoin d'un gros accident? Que s'est-il passé?

La langue

1. Quand vous êtes à l'extérieur de Trois-Rivières, est-ce que les gens vous reconnaissent comme trifluviens à cause de votre accent?
2. Y a-t-il une différence entre le parler de la ville et celui de la campagne?
y a-t-il une différence aussi entre le parler des différentes personnes de Trois-Rivières?
3. Vous-même, est-ce que vous parlez différemment selon que vous êtes avec votre mari, des parents ou des étrangers? Portez-vous parfois plus d'attention à votre langage? Expressions plus choisies ou plus spontanées?
Est-ce que vous parlez de la même façon que vos parents? que pendant votre jeunesse?
4. Que pensez-vous du "joual" ? Pouvez-vous le définir?
Qui selon vous parle "joual"?
Qu'est-ce que c'est, selon vous, "bien parler" ?

5. Certains disent que le "joual" exprime mieux la colère, la joie, les farces que le "bon français", qu'en pensez-vous?
6. Que pensez-vous du français parlé à Trois-Rivières? Est-il satisfaisant? Doit-il être amélioré?
Etes-vous satisfait de la façon dont vous parlez?
7. Croyez-vous qu'on se fait juger par notre façon de parler?
Pourquoi?

BIBLIOGRAPHY .

- Afendras, E.A. (1969). Sociolinguistic history, sociolinguistic geography and bilingualism .In International Congress of Social Sciences, Rome, 1969, pp.663-683
- Albert M.Ethel. (1972). Culture patterning of speech behavior in Burundi . In J.J.Gumperz and Dell Hymes (eds.), Directions in Sociolinguistics. New York: Holt, Rinehart and Winston, Inc. 1972: pp.72-106
- Ardener, E.(ed.). (1971a). Social Anthropology and Language. London: Tavistock Publications.
- Ardener, E. (1971b). Introductory essay: social anthropology and language . In E.Ardener (ed.), Social Anthropology and Language . London: Tavistock Publications. 1971. pp.LX-C11
- Arewa, E.O. and A.Dundes. (1964). Proverbs and the ethnography of speaking folklore . In J.J.Gumperz and D.Hymes (eds.), The ethnography of communication. American Anthropologist, 66,6, pt.11, 1964. pp.70-85
- Argyle, M. (1967). The Psychology of Interpersonal Behaviour. Harmondsworth: Penguin Books.
- Artaud, M-C. and P.Martin. (1968). Répartition de l'énergie articulatoire en français canadien et en français standard . In P.R.Léon (ed.), Recherches sur la Structure Phonique du Français Canadien. Montréal: Studia Phonetica, Didier. 1968. pp.145-161
- Atlas linguistique du Canada Français, Questionnaire. (1953). Québec: Presses de l'Université Laval.
- Bally, C. (1952). Le langage et la vie. Genève: E.Droz.
- Barbeau, V. (1963). Le français du Canada. Montréal: Les publications de l'Académie canadienne-française.
- Barth, F. (1964). Ethnic processes on the Pathan-Baluch boundary . In J.J.Gumperz and D.Hymes (eds.), Directions in sociolinguistics. New York: Holt, Rinehart and Winston Inc. 1972. pp.454-465

- Barth, F. (1966). Models of social organization. Royal Anthropological Institute of Great Britain and Ireland, Occasional Papers. London.
- Barth, F. (ed.). (1969). Ethnic groups and boundaries. The social organization of culture difference. London: Allen & Unwin.
- Basso, K.H. (1970). "To Give up on Words": Silence in Western Apache Culture. In P.P. Giglioli (ed.), Language and social context. Harmondsworth: Penguin Books. 1972. pp.67-87.
- Beauchemin, N. (1972a). Le Questionnaire. Document de travail No.1. Sherbrooke: Université de Sherbrooke.
- Beauchemin, N. (1972b). Quelques traits de prononciation québécoise dans un contexte anglophone qui les influence? document de travail No.2. Sherbrooke: Université de Sherbrooke.
- Beauchemin, N. (1972c). La diphtongaison en Estrie. Document de travail No.4. Sherbrooke: Université de Sherbrooke.
- Beaudry Losique, Mimi. (1974). Le problème du jocal: un essai d'analyse scientifique. In Le Devoir, samedi 16 mars. Montréal.
- Bender, M.L., R.L. Cooper and C.A. Ferguson. (1972). Language in Ethiopia: Implications of a survey for sociolinguistic theory and method. In Language in Society, Vol.1. 1972. pp.215-234
- Bernstein, B. (1964a). Aspects of language and learning in the genesis of the social process. In D. Hymes (ed.), Language in culture and society. New York: Harper & Row. 1964. pp. 251-264
- Bernstein, B. (1964b). Elaborated and restricted codes: their social origins and some consequences. In J.J. Gumperz and D. Hymes (eds.), The ethnography of communication. American Anthropologist. 66, 6 pt. 11: 1964. pp.55-69
- Bernstein, B. (1966). Elaborated and Restricted codes: an outline. In S. Lieberman (ed.), Explorations in Sociolinguistics. The Hague: Mouton, 1966. pp.126-134
- Bernstein, B. (1970). Social class, language and socialization. In P.P. Giglioli (ed.), Language and social context. Harmondsworth: Penguin Books, 1972. pp.157-179
- Bernstein, B. (1972). A sociolinguistic approach to socialization: with some reference to educability. In J.J. Gumperz and D. Hymes (eds.), Directions in sociolinguistics. New York: Holt, Rinehart and Winston, Inc. 1972. pp.465-498
- Bickerton, D. (1971). Inherent variability and variable rules. In Foundations of Language, 7, pp.457-492
- Bierwisch, M. (1968). Two critical problems in accent rules. In E.C. Fudge (ed.), Phonology. Harmondsworth: Penguin Books, 1973, pp. 336-342

- Birdwhistell, R.L. (1972). A kinesic-linguistic exercise: the cigarette scene. In J.J.Gumperz and D.Hymes (eds.), Directions in sociolinguistics. New York: Holt, Rinehart and Winston Inc. 1972, pp.381-405
- Eloch, B. (1950). Phonemics, Transcriptions and Orthographies. In E.C.Fudge (ed.), Phonology. Harmondsworth: Penguin Books, 1973, pp. 83-91
- Blom, J.P. and J.J.Gumperz. (1972). Social meaning in linguistic structure: code-switching in Norway. In J.J.Gumperz and D. Hymes (eds.), Directions in sociolinguistics. New York: Holt, Rinehart and Winston, Inc. 1972, pp.407-435.
- Bloomfield, L. (1933). Language. New York: Holt, Rinehart and Winston, Inc.
- Boas, F. (1911). Linguistics and ethnology. In D.Hymes (ed.), Language in culture and society. New York: Harper & Row, 1964, pp.15-27
- Botha, R.P. (1971). The phonological component of a generative grammar. In E.C.Fudge (ed.), Phonology. Harmondsworth: Penguin Books, 1973, pp.213-232
- Boudreault, M. (1967). Rythme et mélodie: étude instrumentale comparative entre sujets québécois et français. In J.D. Gendron and G. Straka (eds.), Etudes de linguistique franco-canadienne. Paris: Librairie C.Klincksieck, Québec: Les presses de l'Université Laval, 1967, pp.69-89
- Bouthillier, G. and J.Meynaud. (1972). Le choc des langues au Québec, 1760-1970. Montréal: Presses de l'Université du Québec.
- Braga, G. (1969). Proposed methodological model for sociolinguistic research. In International Congress of Social Sciences, Rome, 1969, pp.368-381
- Brazeau, J. (1958). Différences linguistiques et carrières. In M.Rioux and Y.Martin (eds.), La société canadienne-française. Montréal: ed. Hurtubise, 1971, pp.303-315.
- Brazeau, J. (1963). L'émergence d'une nouvelle classe moyenne au Québec. In M.Rioux and Y.Martin (eds.), La société canadienne-française. Montréal: ed.Hurtubise, 1971, pp.325-335
- Bream, C. (1968). La nasalisation des voyelles orales suivies de consonne nasales dans le français et l'anglais parlés au Canada. In P.R.Léon (ed.), Recherches sur la structure phonique du Français canadien, Montréal: Studia Phonetica, Didier, 1968, pp.100-119

- Brent, E. (1971). Canadian French: A Synthesis. Doctoral dissertation, Cornell University. University Microfilms, A Xerox Company. Ann Arbor: Michigan.
- Bright, W. (1964). Social dialect and language history. In D. Hymes (ed.), Language in culture and society. New York: Harper & Row, 1964, pp. 469-472
- Bright, W. (ed.).. (1966). Sociolinguistics. The Hague: Mouton.
- Bright, W. and A. K. Ramanujan. (1964). Sociolinguistic variation and language change. In J. B. Pride and J. Holmes (eds.), Sociolinguistics. Harmondsworth: Penguin Books, 1972, pp. 157-167
- Brown, R. W. and M. Ford. (1961). Address in American English. In D. Hymes (ed.), Language in culture and society. New York: Harper & Row, 1964, pp. 234-245
- Brown, R. W. and A. Gilman. (1960). The pronouns of power and solidarity. In P. P. Giglioli (ed.), Language and social context. Harmondsworth: Penguin Books, 1972, pp. 252-283
- Burling, R. (1970). Man's Many Voices. Language in its Cultural Context. New York: Holt, Rinehart and Winston, Inc.
- Burstynsky, E. J. (1968). Quelques observations de phonologie générative appliquées au français canadien. In P. R. Léon (ed.), Recherches sur la structure phonique du français canadien. Montréal: Studia Phonetica, Didier, 1968, pp. 9-18
- Capell, A. (1966). Studies in socio-linguistics. The Hague: Mouton.
- Carnochan, J. (1960). Vowel harmony in Igbo. In E. C. Fudge (ed.), Phonology. Harmondsworth: Penguin Books, 1973, pp. 200-213.
- Cazden, C. B. (1970). The situation: a neglected source of social class differences in language use. In J. B. Pride and J. Holmes (eds.), Sociolinguistics. Harmondsworth: Penguin Books, 1972, pp. 294-314
- Cedergren, H. and D. Sankoff. (1974). Variable rules: performance as a statistical reflection of competence. In Language, vol. 50, no. 2, 1974, pp. 333-356.
- Charbonneau, R. (1957). La spirantisation du /ʒ/. In Revue de l'Association canadienne de linguistique, vol. 3, no. 1, 1957, pp. 14-17; 71-77
- Charbonneau, R. (1967). Le test phonétique pour l'audiométrie vocale au Canada français. In J. D. Gendron and G. Straka (eds.), Etudes de linguistique franco-canadienne. Paris: Librairie Klincksieck, Québec: Presses de l'Université Laval, 1967, pp. 107-125.

- Chidaine, J.-G. (1967). ϵ et j en saintongeais et en français canadien. In J.D.Gendron and G.Straka (eds.), Etudes de linguistique franco-canadienne. Paris: Librairie Klincksieck, Québec: Presses de l'Université Laval, 1967, pp.144-153
- Chomsky, N. (1965). Aspects of the theory of syntax. Cambridge, Mass.: M.I.T. Press.
- Chomsky, N. and M.Halle. (1968). The sound pattern of English. New York: Harper & Row.
- Cicourel, A.V. (1969). Generative semantics and the structure of social interaction. In International Congress of Social Sciences, Rome, 1969, pp.173-203
- Cohen, M. (1956). Pour une sociologie du langage. Paris.
- Crystal, D. (1969). Prosodic Systems and Intonation in English. London: Cambridge University Press.
- Crystal, D. (1971). Prosodic and Paralinguistic Correlates of Social Categories. In E.Ardener (ed.), Social anthropology and language. London: Tavistock Publications, 1971, pp. 185-206.
- Das Gupta, J. (1968). Language diversity and national development. In J.A.Fishman, C.A.Ferguson and J.Das Gupta (eds.), Language problems of developing nations. New York: Wiley, 1968, pp.17-27.
- Das Gupta, J. and J.J.Gumperz. (1968). Language, communication and control in North India. In J.A.Fishman, C.A.Ferguson and J.Das Gupta (eds.), Language problems of developing nations. New York: Wiley, 1968, pp.151-167.
- Davis, A.L. and L.M.Davis. (1969). Questionnaires. Recordings of Standard English questionnaire. In Orbis, 18.2, pp. 385-404.
- Debrie-Maury, N.G. (1968). Les archiphonèmes Γ \cup η dans le français canadien et dans le parler normand. In P.R.Léon (ed.), Recherches sur la structure phonique du français canadien. Montréal: Studia Phonetica, Didier, 1968, pp.210-233.
- Decamp, D. (1972). Hypercorrection and rule generalization. In Language in Society, vol.1, 1972, pp.87-91
- Deffontaines, P. (1953). Le rang, type de peuplement rural du Canada français. In M.Rioux and Y.Martin (eds.), La société canadienne-française. Montréal: Hurtubise, 1971, pp.19-33.

- Denison, N. (1969). Sociolinguistic aspects of plurilingualism. In International congress of social sciences, Rome, 1969, pp.255-279.
- Denison, N. (1971). Some observations on language variety and plurilingualism. In J.B.Pride and J. Holmes (eds.), Sociolinguistics. Harmondsworth: Penguin Books, 1972, pp.65-78.
- De Saussure, F. (1916). Cours de linguistique générale. Paris: Payot.
- Dofny, J. and M.Rioux. (1962). Les classes sociales au Canada français. In M.Rioux and Y.Martin (eds.), La société canadienne-française. Montréal: ed.Hurtubise, 1971, pp.315-325.
- Dossire Economique, Serie 1969-70. Agglomération de Trois-Rivières. Etudes régionales, Direction générale de l'Economie industrielle, Ministère de l'Industrie et du Commerce, Québec.
- Dulong, G. (1954). L'Atlas linguistique de la Gaspésie. In Revue de l'Association canadienne de linguistique, vol.1, no.1, pp.23-26.
- Dulong, G. (1966). Bibliographie linguistique du Canada français. Québec: Presses de l'Université Laval.
- Dulong, G. (1967). L'anglicisme au Canada français: étude historique. In J.D.Gendron and G.Straka (eds.), Etudes de linguistique franco-canadienne. Paris: Librairie Klincksieck, Québec: Presses de l'Université Laval, 1967, pp.9-15.
- Dumont, F. (1962). L'étude systématique de la société globale canadienne-française. In M.Rioux and Y.Martin (eds.), La société canadienne-française. Montréal: ed.Hurtubise, 1971, pp.389-404.
- Dumont, F. and G.Rocher. (1961). Introduction à une sociologie du Canada français. In M.Rioux and Y.Martin (eds.), La société canadienne-française. Montréal: ed.Hurtubise, 1971, pp.189-211.
- Ervin-Tripp, Susan. (1964). An analysis of the interaction of language, topic and listener. In J.J.Gumperz and D.Hymes (eds.), The ethnography of communication. American Anthropologist. 66,6, pt.11, 1964, pp.86-102.
- Ervin-Tripp, Susan. (1969a). Sociolinguistics. In J.Fishman (ed.), Advances in the sociology of language, vol.1. The Hague: Mouton, 1971, pp.15-92.
- Ervin-Tripp, Susan. (1969b). Sociolinguistic rules of address. In J.B.Pride and J.Holmes (eds.), Sociolinguistics. Harmondsworth: Penguin Books, 1972, pp.225-241.
- Ervin-Tripp, Susan. (1972). On sociolinguistic rules: alternation and co-occurrence. In J.J.Gumperz and D.Hymes (eds.), Directions in sociolinguistics. New York: Holt, Rinehart and Winston, Inc. 1972, pp.213-251.

- Falardeau, J.C. (1953). L'évolution de nos structures sociales. In M.Rioux and Y.Martin (eds.), La société canadienne-française. Montréal: ed.Hurtubise, 1971, pp.119-137.
- Ferguson, C.A. (1959). Diglossia. In P.P.Giglioli (ed.), Language and social context. Harmondsworth: Penguin Books, 1972, pp.232-252.
- Ferguson, C.A. (1964). Baby talk in six languages. In J.J. Gumperz and D.Hymes (eds.), The ethnography of communication. American Anthropologist. 66,6, pt.11, 1964, pp. 103-114.
- Ferguson, C.A. (1966). National sociolinguistics profile formulas. In W.Bright (ed.), Sociolinguistics. The Hague: Mouton, 1966, pp.309-314.
- Ferguson, C.A. (1968a). Language development. In J.A.Fishman, C.A.Ferguson and J.Das Gupta (eds.), Language problems of developing nations. New York: Wiley, 1968, pp.27-37.
- Ferguson, C.A. (1968b). St.Stefan of Perm and applied linguistics. In J.A.Fishman, C.A.Ferguson and J.Das Gupta (eds.), Language problems of developing nations. New York: Wiley, 1968, pp. 253-267.
- Ferguson, C.A. (1970). The role of Arabic in Ethiopia, a sociolinguistic perspective. In J.B.Pride and J.Holmes (eds.), Sociolinguistics. Harmondsworth: Penguin Books, 1972, pp. 112-125.
- Fischer, J.L. (1958). Social influence in the choice of a linguistic variant. In Word, 14, 1958, pp.47-56. (Reprinted in D.Hymes (ed.), Language in culture and society. New York: Harper & Row, 1964, pp.483-488).
- Fischer, J.L. (1964). Words for self and others in some Japanese families. In J.J.Gumperz and D.Hymes (eds.), The ethnography of communication. American Anthropologist. 66,6, pt.11, 1964, pp.115-132.
- Fischer, J.L. (1965). The stylistic significance of consonantal Sandhi in Trukese and Ponapean. In J.J.Gumperz and D.Hymes (eds.), Directions in Sociolinguistics. New York: Holt, Rinehart and Winston, Inc., 1972, pp.498-512.
- Fishman, J.A. (1964). Language maintenance and language shift as a field of inquiry. In Linguistics, 9, pp.32-70
- Fishman, J.A. (1966). Language Loyalty in the United States. The Hague: Mouton.
- Fishman, J.A. (ed.). (1968a). Readings in the sociology of language. The Hague: Mouton.
- Fishman, J.A. (1968b). Sociolinguistics and the language problems of developing countries. In J.A.Fishman, C.A.Ferguson and J.Das Gupta (eds.), Language problems of developing nations. New York: Wiley, 1968, pp.3-17.
- Fishman, J.A. (1968c). Nationality-Nationalism and Nation-nationism. In J.A.Fishman, C.A.Ferguson and J.Das Gupta (eds.), Language problems of developing nations. New York: Wiley, 1968, pp.39-53.

- Fishman, J.A. (1968d). Language problems and types of political and sociocultural integration: a conceptual summary. In J.A. Fishman, C.A. Ferguson and J. Das Gupta (eds.), Language problems of developing nations. New York: Wiley, 1968, pp.491-499.
- Fishman, J.A. (1970). Sociolinguistics: A brief introduction. Newbury House publications, Mass.
- Fishman, J.A. (ed.). (1971a). Advances in the sociology of Language. vol.1. The Hague: Mouton.
- Fishman, J.A. (1971b). The relations between Micro- and Macro-Sociolinguistics in the Study of Who speaks What language to Whom and When. In J.B. Pride and J. Holmes (eds.), Sociolinguistics. Harmondsworth: Penguin Books, 1972, pp.15-33.
- Fishman, J.A. (1972a). The sociology of language. Newbury House publications, Mass.
- Fishman, J.A. (1972b). Domains and the relationship between Micro- and Macrosociolinguistics. In J.J. Gumperz and D. Hymes (eds.), Directions in sociolinguistics. New York: Holt, Rinehart and Winston, Inc., 1972, pp.435-454.
- Fishman, J.A., C.A. Ferguson and J. Das Gupta (eds.). (1968). Language problems of developing nations. New York: Wiley.
- Foucher, P. (1969). Traité de Prononciation française. Paris: Librairie Klincksieck.
- Frake, C.O. (1964). How to ask for a drink in Subanon. In P.P. Giglioli (ed.), Language and social context. Harmondsworth: Penguin Books, 1972, pp.87-95.
- Friedrich, P. (1966a). Structural implications of Russian pronominal usage. In W. Bright (ed.), Sociolinguistics. The Hague: Mouton, 1966, pp.214-253.
- Friedrich, P. (1966b). The linguistic reflex of social change: from Tsarist to Soviet Russian kinship. In S. Lieberman (ed.), Explorations in sociolinguistics. The Hague: Mouton, 1966, pp.31-58
- Friedrich, P. (1972). Social context and semantic feature: the Russian pronominal usage. In J.J. Gumperz and D. Hymes (eds.), Directions in sociolinguistics. New York: Holt, Rinehart and Winston, Inc. 1972, pp.270-301.
- Fudge, E.C. (1972). On the notion "Universal Phonetic Framework". In E.C. Fudge (ed.), Phonology. Harmondsworth: Penguin Books, 1973, pp.172-181.
- Fudge, E.C. (ed.). (1973). Phonology. Harmondsworth: Penguin Books.
- Gallagher, C.F. (1968). North African problems and prospects: language and identity. In J.A. Fishman, C.A. Ferguson and J. Das Gupta (eds.), Language problems of developing nations. New York: Wiley, 1968, pp.129-151

- Garfinkel, H. (1972). Remarks on ethnomethodology. In J.J. Gumperz and D.Hymes (eds.), Directions in Sociolinguistics. New York: Holt, Rinehart and Winston, Inc. 1972, pp.301-325.
- Garigue, P. (1957). Evolution et continuité dans la société rurale canadienne-française. In M.Rioux and Y.Martin (eds.), La société canadienne-française. Montréal: ed.Hurtubise, 1971, pp.137-149.
- Garvin, P.L. (1964). The standard language problem: concepts and methods. In D.Hymes (ed.), Language in culture and society. New York: Harper & Row, 1964, pp.521-523.
- Geertz, C. (1960). Linguistic etiquette. In J.B.Pride and J.Holmes (eds.), Sociolinguistics. Harmondsworth: Penguin Books, 1972, pp.167-180.
- Gendron, J.-D. (1955). Quelques traits phonétiques d'une paroisse gaspésienne. In Revue de l'Association canadienne de linguistique, vol.1, no.1, 1955, pp.6-14.
- Gendron, J.-D. (1959). Désonorisation des voyelles en franco-canadien. In Revue de l'Association canadienne de linguistique, vol.5, no.2, 1959, pp.99-109.
- Gendron, J.-D. (1961). La méthode radiographique appliquée à la comparaison des articulations vocaliques en français canadien et en français parisien. In Proceedings of the fourth international congress of phonetics sciences, Helsinki, 1961, pp.155-167.
- Gendron, J.-D. (1966). Tendances phonétiques du français parlé au Canada. Paris: Librairie Klincksieck, Québec: Presses de l'Université Laval.
- Gendron, J.-D. (1967). Le phonétisme du français canadien du Québec face à l'adstrat anglo-américain. In J.-D. Gendron and G.Straka (eds.), Etudes de linguistique franco-canadienne. Paris: Librairie Klincksieck, Québec: Presses de l'Université Laval, 1967, pp.15-69.
- Gendron, J.-D. and G.Straka (eds.). (1967). Etudes de linguistique franco-canadienne. Paris: Librairie Klincksieck, Québec: Presses de l'Université Laval.
- General characteristics of the administrative region of Trois-Rivières, region no.4. Regional studies, Department of Industry and Commerce, Québec 1971.
- Giglioli, P.P. (1969). Some remarks on socio-linguistics. In International congress of social sciences, Rome, 1969, pp.530-543.
- Giglioli, P.P. (ed.). (1972). Language and social context. Harmondsworth: Penguin Books.

- Giles, H. (1973). Accent mobility: a model and some data. In Anthropological Linguistics, february 1973, pp.87-105.
- Giles, H. and R. Bourhis. (1973). Dialect perception revisited. In Quarterly Journal of Speech, October 1973, pp.337-342.
- Giles, H., R. Bourhis and Ann Davies. (1973). Prestige speech styles: the imposed norm and inherent value hypotheses. Abstract of a paper presented to the 1Xth International Congress of Anthropological Sciences, Chicago, August 28th - September 8th.
- Giles H., D.M. Taylor and R. Bourhis. (1973). Towards a theory of interpersonal accommodation through language: some Canadian data. In Language in Society, 2, pp.177-192.
- Gilliéron J. and E. Edmont. (1902-10). Atlas linguistique de la France. Paris.
- Gimson, A.C. (1970). Second edition. An Introduction to the Pronunciation of English. London: Arnold.
- Ginsberg, R. (1968). La détente consonantique en français canadien et en français standard. In P.R. Léon (ed.), Recherches sur la structure phonique du français canadien. Montréal: Studia Phonetica, Didier, 1968, pp.131-145.
- Gleason, H.A. (1961). An Introduction to Descriptive Linguistics. 2nd revised edition. New York: Holt, Rinehart and Winston, Inc.
- Goffman, E. (1964). The neglected situation. In J.J. Gumperz and D. Hymes (eds.), The ethnography of communication. American Anthropologist. 66, 6, pt. 11, 1964, pp.133-137.
- Goodenough, W.H. (1964a). Cultural anthropology and linguistics. In D. Hymes (ed.), Language in culture and society. New York: Harper & Row, 1964, pp.36-40.
- Goodenough, W.H. (1964b). Property and language on Truk: some methodological considerations. In D. Hymes (ed.), Language in culture and society. New York: Harper & Row, 1964, pp.185-189.
- Goody J. and I. Watt. (1963). The consequences of literacy. In P.P. Giglioli (ed.), Language and social context. Harmondsworth: Penguin Books, 1972, pp.311-358.
- Greimas, J. (1969). Des modèles théoriques en socio-linguistique. In International congress of social sciences, Rome, 1969, pp.95-111.
- Grimshaw, A.D. (1971). Sociolinguistics. In J.A. Fishman (ed.), Advances in the sociology of language, vol.1. The Hague: Mouton, 1971, pp.92-152.

- Guilford, J.P. (1965). 4th edition. Fundamental statistics in psychology and education. New York: McGraw-Hill, Inc.
- Guindon, H. (1960). Réexamen de l'évolution sociale du Québec. In M. Rioux and Y. Martin (eds.), LA société canadienne-française. Montréal: ed. Hurtubise, 1971, pp.149-173.
- Gumperz, J.J. (1964a). Linguistic and social interaction in two communities. In J.J. Gumperz and D. Hymes (eds.), The ethnography of communication. *American anthropologist*. 66,6, pt.11, pp.137-154.
- Gumperz, J.J. (1964b). Speech variation and the study of Indian civilization. In D. Hymes (ed.), Language in culture and society. New York: Harper & Row, 1964, pp.416-423.
- Gumperz, J.J. (1966). On the ethnography of linguistic change. In W. Bright (ed.), Sociolinguistics. The Hague: Mouton, 1966, pp.27-49.
- Gumperz, J.J. (1968). The speech community. In P.P. Giglioli (ed.), Language and social context. Harmondsworth: Penguin Books, 1972, pp.219-232.
- Gumperz, J.J. (1970). Sociolinguistics and communication in small groups. In J.B. Pride and J. Holmes (eds.), Sociolinguistics. Harmondsworth: Penguin Books, 1972, pp.203-225.
- Gumperz, J.J. (1971). Language in Social Groups. Essays by J.J. Gumperz. Language Science and National Development Series, Anwar S. Dil, General Editor. Palo Alto, Calif.: Stanford University Press.
- Gumperz, J.J. (1972a). Introduction. In J.J. Gumperz and D. Hymes (eds.), Directions in sociolinguistics. New York: Holt, Rinehart and Winston, Inc. 1972, pp.1-26.
- Gumperz, J.J. (1972b). On the communicative competence of bilinguals: some hypotheses and suggestions for further research. In Language in Society, vol.1, 1972, pp.143-154.
- Gumperz, J.J. and D. Hymes (eds.). (1964). The ethnography of communication. *American anthropologist*. 66,6, pt.11.
- Gumperz, J.J. and D. Hymes (eds.). (1972). Directions in sociolinguistics. New York: Holt, Rinehart and Winston, Inc.
- Gupta, N.S. (1969). Sociolinguistics and the social change in India. In International congress of social sciences, Rome, 1969, pp.719-727.
- Haugen, E. (1966a). Language conflict and language planning. Cambridge, Mass.: Harvard University Press.
- Haugen, E. (1966b). Dialect, Language, Nation. In J.B. Pride and J. Holmes (eds.), Sociolinguistics. Harmondsworth: Penguin Books, 1972, pp.97-112.
- Haugen, E. (1968). The Scandinavian languages as cultural artifacts. In J.A. Fishman, C.A. Ferguson and J. Das Gupta (eds.), Language problems of developing nations. New York: Wiley, 1968, pp.267-285.

- Heise, D.R. (1966). Social status, attitudes, and word connotations. In S.Lieberson (ed.), Explorations in sociolinguistics. The Hague: Mouton, 1966, pp.99-112.
- Helmer, J. (1969). The sociology of language. In International congress of social sciences, Rome, 1969, pp.727-753.
- Hertzler, J.O. (1966). Social uniformation and language. In S.Lieberson (ed.), Explorations in sociolinguistics. The Hague: Mouton, 1966, pp.170-185.
- Hockett, C.F. (1958). A course in modern linguistics. New York: Macmillan.
- Hoijer, H. (1964). Linguistic and cultural change. In D.Hymes (ed.), Language in culture and society. New York: Harper & Row, 1964, pp.455-467.
- Holder, M. (1968). Etude sur l'intonation comparée de la phrase énonciative en français canadien et en français standard. In P.R.Léon (ed.), Recherches sur la structure phonique du français canadien. Montréal: Studia Phonetica, Didier, 1968, pp.175-192.
- Howell, R. (1968). Linguistic choice and levels of social change. In American Anthropologist, 70, 1968, pp.553-559.
- Hunt, C.L. (1966). Language choice in a multilingual society. In S.Lieberson (ed.), Explorations in sociolinguistics. The Hague: Mouton, 1966, pp.112-126.
- Hymes, D. (ed.). (1964a). Language in culture and society. New York: Harper & Row.
- Hymes, D. (1964b). Introduction: toward ethnographies of communication. In J.J.Gumperz and D.Hymes (eds.), The ethnography of communication. American Anthropologist, 66, 6, pt.11, pp. 1-34.
- Hymes, D. (1966a). Two types of linguistic relativity. In W.Bright (ed.), Sociolinguistics. The Hague: Mouton, 1966, pp.114-165.
- Hymes, D. (1966b). On "anthropological linguistics" and congeners. In American Anthropologist, 68, 1966, pp. 143-153.
- Hymes, D. (1967). Models of the interaction of language and social setting. In Journal of Social Issues, 23 (2), pp.8-28.
- Hymes, D. (1969). Linguistic theory and the functions of speech. In International congress of social sciences. Rome, 1969, pp.111-145.
- Hymes, D. (ed.). (1971a). Pidginization and creolization of languages. London: Cambridge University Press.

- Hymes, D. (1971b). Sociolinguistics and the ethnography of speaking. In E. Ardener (ed.), Social anthropology and language. London: Tavistock publications, 1971, pp.47-95.
- Hymes, D. (1971c). On communicative competence. In J. B. Pride and J. Holmes (eds.), Sociolinguistics. Harmondsworth: Penguin Books, 1972, pp.269-294.
- Hymes, D. (1972). Models of the interaction of language and social life. In J. J. Gumperz and D. Hymes (eds.), Directions in sociolinguistics. New York: Holt, Rinehart and Winston, Inc., 1972, pp.35-72.
- Ibbotson, A. (1968). Les oppositions phonologiques dans les archiphonèmes A, E, O, EU en position accentuée, chez un groupe de jeunes torontonniens francophones: étude auditive et instrumentale. In P. R. Léon (ed.), Recherches sur la structure phonique du français canadien. Montréal: Studia Phonetica, Didier, 1968, pp.42-61.
- Inglehart, R. and M. Woodward. (1967). Language conflicts and the political community. In P. P. Giglioli (ed.), Language and social context. Harmondsworth: Penguin Books, 1972, pp.358-379.
- International congress of social sciences: Proceedings of international days of sociolinguistics, (1969). Rome 15-17 September: Instituto Luigi Sturzo.
- Inventaire industriel. Infrastructure industrielle. Région de Trois-Rivières. (1972). Montréal: publié par le Ministère de l'Industrie et du Commerce.
- Jackson, D. M. (1968). Etude du système vocalique du parler de Gravelbourg (Saskatchewan). In P. R. Léon (ed.), Recherches sur la structure phonique du français canadien. Montréal: Studia Phonética, Didier, 1968, pp.61-79.
- Jakobson, R. and M. Halle (1956). The distinctive features. In E. C. Fudge (ed.), Phonology. Harmondsworth: Penguin Books, 1973, pp.151-159.
- Jespersen, O. (1925). Mankind, nation and the individual from a linguistic point of view. Oslo. Reprinted (1964). Bloomington: Indiana University Press.
- Jones, D. (1957). The history and meaning of the term "Phoneme". In E. C. Fudge (ed.), Phonology. Harmondsworth: Penguin Books, 1973, pp.17-35.
- Juneau, M. (1972). Contribution à l'histoire de la prononciation française au Québec. Etudes des graphies des documents d'Archives. Langue et littérature françaises au Canada, 8, Québec: Presses de l'Université Laval.

- Kelly, L.G. (ed.). (1967). Description et mesure du bilinguisme. Colloque international, Université de Moncton, 6-14 juin. Unesco et University of Toronto Press.
- Kisseberth, C.W. (1970). On the functional unity of phonological rules. In E.C. Fudge (ed.), Phonology. Harmondsworth: Penguin Books, 1973, pp.257-277.
- Kloss, H. (1966). Types of multilingual communities: a discussion of ten variables. In S. Lieberman (ed.), Explorations in sociolinguistics. The Hague: Mouton, 1966, pp.7-18.
- Kloss, H. (1968). Notes concerning a language-nation typology. In J.A. Fishman, C.A. Ferguson and J. Das Gupta (eds.), Language problems of developing nations. New York: Wiley, 1968, pp.69-87.
- Laberge, Suzanne and Michèle Chiasson-Lavoie. (1971). Attitudes face au français parlé à Montréal et degrés de conscience de variables linguistiques. In Linguistic Diversity in Canadian Society, Regna Darnell (ed.). Edmonton: Linguistic Research, 1971, pp.89-126.
- Labov, W. (1963). The social motivation of a sound change. In Word, XIX, 1963, pp.273-309.
- Labov, W. (1964a). Phonological correlates of social stratification. In J.J. Gumperz and D. Hymes (eds.), The ethnography of communication. American Anthropologist, 66, 6, pt.11, 1964, pp.164-176.
- Labov, W. (1964b). Hypercorrection by the lower middle class as a factor in linguistic change. In W. Bright (ed.), Sociolinguistics. The Hague: Mouton, 1966, pp.84-101.
- Labov, W. (1966a). The social stratification of English in New York city. Washington, D.C. : Center for Applied Linguistics. ✓
- Labov, W. (1966b). The effect of social mobility on linguistic behavior. In S. Lieberman (ed.), Explorations in sociolinguistics. The Hague: Mouton, 1966, pp.58-76. ✓
- Labov, W. (1968). The reflection of social processes in linguistic structures. In J.A. Fishman (ed.), Readings in the sociology of language. The Hague: Mouton, 1968, pp.240-251.
- Labov, W. (1969a). Contraction, deletion, and inherent variability of the English copula. In Language, 45, 1969, pp. 715-762.
- Labov, W. (1969b). The logic of Nonstandard English. In P.P. Giglioli (ed.), Language and social context. Harmondsworth: Penguin Books, 1972, pp.179-217.
- Labov, W. (1970). The study of language in its social context. In J.A. Fishman (ed.), Advances in the sociology of language, vol.1. The Hague: Mouton, 1971, pp.152-216.
- Labov, W. (1972a). On the mechanism of linguistic change. In J.J. Gumperz and D. Hymes (eds.), Directions in sociolinguistics. New York: Holt, Rinehart and Winston, Inc. 1972, pp.512-539.

- Labov, W. (1972b). Sociolinguistic Patterns. Philadelphia: University of Pennsylvania Press.
- Labov, W., P. Cohen, C. Robins and J. Lewis. (1968). A study of the nonstandard English of Negro and Puerto Rican speakers in New York city. Final Report, Cooperative Research Project no. 3288, vols. 1 & 11. Washington, D.C.: Office of Education.
- Ladefoged, P. (1960). The nature of vowel quality. In Revista Do Laboratorio de Fonética Experimental, vol. V. University of Coimbra, 1960, pp. 73-159.
- La Follette, J.E. (1960). Observations sur le comportement du Schwa en franco-canadien. In Revue de l'Association Canadienne de Linguistique, vol. 6, no. 1, 1960, pp. 29-35.
- La Follette, J.E. (1961). Un curieux emploi de la négation en français canadien. In Revue de l'Association Canadienne de Linguistique, vol. 7, no. 1, 1961, pp. 15-26.
- Lambert, W.E. (1967). A social psychology of bilingualism. In Journal of Social Issues, XXIII, 2, pp. 91-109.
- Lambert, W.E. (1972). Language, Psychology and Culture. Stanford University Press.
- Landry, A. (1933). Bribes d'histoire. Trois-Rivières: éditions du Bien Public.
- Laver, J. and G. Hutchesson (eds.). (1972). Communication in face to face interaction. Harmondsworth: Penguin Books.
- Lefebvre, H. (1966). Le langage et la vie. Paris: Gallimard.
- Léon, P.R. (1967). H et r en patois normand et en français canadien. In J.D. Gendron and G. Straka (eds.), Études de linguistique franco-canadienne. Paris: Librairie Klincksieck, Québec: Presses de l'Université Laval, 1967, pp. 125-144.
- Léon, P.R. (ed.). (1968). Recherches sur la structure phonique du français canadien. Montréal: Studia Phonetica, Didier.
- Léon, P.R. and M. Léon. (1969). Introduction à la phonétique corrective. Paris: Hachette.
- Léon, P.R. and M. Nemni. (1967). Franco-canadien et français standard: problèmes de perceptions des oppositions vocales. In P.R. Léon (ed.), Recherches sur la structure phonique du français canadien. Montréal: Studia Phonetica, Didier, 1968, pp. 18-36.

- Léon, P.R., E.F. James and G. Sévigny. (1968). Observations sur une forme progressive en canadien-français. In Revue de l'Association Canadienne de Linguistique, XIII, 2, pp. 94-99.
- Leroy. (1963). Les grands courants de la linguistique moderne. Paris: Presses Universitaires de France.
- Levine, L. and H.J. Crockett, Jr. (1966). Speech variation in a Piedmont community: postvocalic r. In S. Lieberman (ed.), Explorations in sociolinguistics. The Hague: Mouton, 1966, pp. 76-99.
- Levi-Strauss, C. (1964). Structural analysis in linguistics and anthropology. In D. Hymes (ed.), Language in culture and society. New York: Harper & Row, 1964, pp. 40-51.
- Levi-Strauss, C., R. Jakobson, C.F. Voegelin and T.A. Sebeok. (1953). Results of the Conference of Anthropologists and Linguists. Baltimore: Waverly Press.
- Lieberman, S. (ed.). (1966). Explorations in sociolinguistics. The Hague: Mouton.
- Lieberman, S. (1969). Linguistic and ethnic segregation in Montréal. In International congress of social sciences, Rome, 1969, pp. 753-783.
- Lieberman, S. (1970). Language and Ethnic Relations in Canada. New York and Toronto: Wiley.
- Lotz, J. (1964). On language and culture. In D. Hymes (ed.), Language in culture and society. New York: Harper & Row, 1964, pp. 182-185.
- Lyons, J. (1962). Phonemic and non-phonemic phonology. In E.C. Fudge (ed.), Phonology. Harmondsworth: Penguin Books, 1973, pp. 190-200.
- Lyons, J. (1968). Introduction to theoretical linguistics. London: Cambridge University Press.
- Lyons, J. (ed.). (1970). New Horizons in Linguistics. Harmondsworth: Penguin Books.
- McDavid, R.I. (1954). Linguistic geography in Canada: an introduction. In Revue de l'Association canadienne de linguistique, vol. 1, no. 1, 1954, pp. 3-9.
- McDavid, R.I. (1964). Postvocalic -r in South Carolina: a social analysis. In D. Hymes (ed.), Language in culture and society. New York: Harper & Row, 1964, pp. 473-480.
- McDavid, R.I. (1966). Dialect differences and social differences in an urban society. In W. Bright (ed.), Sociolinguistics. The Hague: Mouton, 1966.

- McIntosh, A. (1952). Introduction to a survey of Scottish dialects. Edinburgh: Thomas Nelson.
- McIntosh, A. (1963). Language and style. In J.B.Pride and J.Holmes (eds.), Sociolinguistics. Harmondsworth: Penguin Books, 1972, pp.241-252.
- Macnamara, J. (1967). Problems of bilingualism. Journal of Social Issues, 23:2.
- Mackey, W.F. (1962). The description of bilingualism. In Revue de l'Association Canadienne de Linguistique, 7, 1962, pp.58-85.
- Mackey, W.F. (1965). Bilingual interference: its analysis and measurement. In Journal of Communication, 15, 1965, pp.239-249.
- Mackey, W.F. (1966). The measurement of bilingual behavior. In The Canadian Psychologist, 7, 1966, pp.75-90.
- Mackey, W.F. (1967). Le bilinguisme, phénomène mondial. Montréal: Harvest House.
- Mackey, W.F. (1969). Measuring cultural difference through concept categories. In International congress of social sciences, Rome, 1969, pp.783-813.
- Malinowski, B. (1964). The dilemma of contemporary linguistics. In D.Hymes (ed.), Language in culture and society. New York: Harper & Row, 1964, pp.63-65.
- Malkiel, Y. (1960). Paradigmatic resistance to sound change. In Language, 36, 1960, pp.281-346.
- Malmberg, B. (1954). La Phonétique. Paris: Presses Universitaires de France. Coll."Que Sais-je?".
- Martinet, A. (1945). La prononciation du français contemporain. Paris.
- Martinet, A. (1952). Function, structure and sound change. In Word, VIII, 1952, pp.1-32.
- Martinet, A. (1955). Economie des changements phonétiques. Berne: A.Francke.
- Martinet, A. (1960). Elements de linguistique générale. Paris: Armand Colin.
- Martinet, A. (1965). La linguistique synchronique. Paris: Presses Universitaires de France.
- Meillet, A. (1921). Linguistique historique et linguistique générale. Vol.1 & 2. Paris: La Société Linguistique de Paris.
- Mills, F.E.Jr. (1971). L'espace sociolinguistique et les systèmes idéolinguistiques: la France et les français. In Studia Linguistica, XXV, 1, pp.21-52.

Monographie de la région administrative no.4: Trois-Rivières.

- (1971). Etudiants de géographie: Université du Québec à Trois-Rivières. Published by the Ministère des Communications, Québec.
- Moulton, W.A. (1962). Dialect geography and the concept of phonological space. In Word, XVIII, 1962, pp.23-33.
- Neustupny, J.V. (1968). Some general aspects of "language" problems and "language" policy in developing societies. In J.A.Fishman, G.A.Ferguson and J.Das Gupta (eds.), Language problems of developing nations, New York: Wiley, 1968, pp.285-295.
- Opitz, H. (1968). Le "A" inaccentué dans le parler français du sud de l'Ontario. In P.R.Léon (ed.), Recherches sur la structure phonique du français canadien. Montréal: Studia Phonetica, Didier, 1968, pp.79-88.
- Pagliari, A. (1969). Linguistics and sociology. In International congress of social sciences, Rome, 1969, pp.35-53.
- Perren, G.E. and J.L.M.Trim (eds.). (1969). Applications of linguistics. Selected papers of the second international congress of applied linguistics, Cambridge 1969. London: Cambridge University Press.
- Pike, K.L. (1947). Grammatical prerequisites to phonemic analysis. In E.C.Fudge (ed.), Phonology. Harmondsworth: Penguin Books, 1973, pp.115-136.
- Pike, K.L. (1964). Towards a theory of the structure of human behavior. In D.Hymes (ed.), Language in culture and society. New York: Harper & Row, 1964, pp.54-61.
- Postal, P.M. (1968). Non-phonetic properties in phonology. In E.C.Fudge (ed.), Phonology. Harmondsworth: Penguin Books, 1973, pp.136-151.
- Pride, J.B. (1970). Sociolinguistics. In J.Lyons (ed.), New horizons in linguistics. Harmondsworth: Penguin Books, 1970, pp.287-302.
- Pride, J.B. (1971a). The Social Meaning of Language. London: Oxford University Press.
- Pride, J.B. (1971b). Customs and cases of verbal behaviour. In E.Ardener (ed.), Social anthropology and language. London: Tavistock publications, 1971, pp.95-121.
- Pride, J.B. and J.Holmes (eds.), (1972), Sociolinguistics. Harmondsworth: Penguin Books.
- Reichstein, R. (1960). Etudes des variations sociales et géographiques des faits linguistiques. In Word, vol.16, 1960, pp.55-99.

- Ricciuti, A.J. (1968). Les occlusives sourdes /p/ /t/ /k/ à l'initiale en français canadien et en français standard. In P.R.Léon (ed.), Recherches sur la structure phonique du français canadien. Montréal: Studia Phonetica, Didier, 1968, pp.119-131.
- Rioux, M. (1959). Notes sur le développement socio-culturel du Canada français. In M.Rioux and Y.Martin (eds.), La société canadienne-française. Montréal: ed.Hurtubise, 1971, pp.173-189.
- Rioux, M. and Y.Martin (eds.). (1971). La société canadienne-française. Montréal: ed.Hurtubise.
- Robins, R.H. (1964). General Linguistics: An Introductory Survey. London: Longmans.
- Robinson, Lynda. (1968). Etude du rythme syllabique en français canadien et en français standard. In P.R.Léon (ed.), Recherches sur la structure phonique du français canadien. Montréal: Studia Phonetica, Didier, 1968, pp.161-175.
- Robinson, W.P. (1972). Language and social behaviour. Harmondsworth: Penguin Books.
- Rocher, G. (1962). Les recherches sur les occupations et la stratification sociale. In M.Rioux and Y.Martin (eds.), La société canadienne-française. Montréal: ed.Hurtubise, 1971, pp.335-349.
- Rohrer, C. (1967). The treatment of the French nasal vowels in generative phonology. In E.C.Fudge (ed.), Phonology. Harmondsworth: Penguin Books, 1973, pp.232-242.
- Rona, J.P. (1966). The social and cultural status of Guarani in Paraguay. In W.Bright (ed.), Sociolinguistics. The Hague: Mouton, 1966.
- Rubin, J. (1968). Acquisition and proficiency. In J.B. Pride and J.Holmes (eds.), Sociolinguistics. Harmondsworth: Penguin Books, 1972, pp.350-367.
- Sacks, H. (1972). On the analyzability of stories by children. In J.J.Gumperz and D.Hymes (eds.), Directions in sociolinguistics. New York: Holt, Rinehart and Winston, Inc., 1972, pp.325-346.
- Salisbury, R.F. (1962). Notes on bilingualism and linguistic change in New Guinea. In J.B.Pride and J.Holmes (eds.), Sociolinguistics. Harmondsworth: Penguin Books, 1972, pp.52-65.

- Sankoff, G. (1969). Mutual intelligibility, bilingualism and linguistic boundaries. In International congress of social sciences, Rome, 1969, pp.839-849.
- Sankoff, G. (1971). Language use in multilingual societies: some alternative approaches. In J.B.Pride and J.Holmes (eds.), Sociolinguistics. Harmondsworth: Penguin Books, 1972, pp.33-52.
- Sankoff, G. (1972). A quantitative paradigm for the study of communicative competence. Paper prepared for the Conference on the Ethnography of Speaking, Texas 1972.
- Sankoff, G. and H.Cedergren. (1971). Some results of a sociolinguistic study of Montréal French. In Linguistic Diversity in Canadian Society, R.Darnell (ed.). Edmonton: Linguistic Research, 1971, pp.61-87.
- Sankoff, G. and D.Sankoff. (1971). Sample survey methods and computer assisted analysis in the study of grammatical variation. Unpublished paper, University of Montréal.
- Sapir, E. (1921). Language. New York: Harcourt, Brace.
- Sapir, E. (1925). Sound patterns in language. In E.C.Fudge (ed.), Phonology. Harmondsworth: Penguin Books, 1973, pp.101-115.
- Sapir, E. (1931). Conceptual categories in primitive languages. In D.Hymes (ed.), Language in culture and society. New York: Harper & Row, 1964, pp.128-129.
- Schegloff, E.A. (1968). Sequencing in conversational openings. In J.J.Gumperz and D.Hymes (eds.), Directions in sociolinguistics. New York: Holt, Rinehart and Winston, Inc. 1972, pp.346-381.
- Schegloff, E.A. (1971). Notes on a conversational practice: formulating place. In P.P.Giglioli (ed.), Language and social context. Harmondsworth: Penguin Books, 1972, pp.95-136.
- Schogt, H.G. (1968). Une "case vide": la phonologie diachronique du français canadien. In P.R.Léon (ed.), Recherches sur la structure phonique du français canadien. Montréal: Studia Phonetica, Didier, 1968, pp.1-9.
- Searle, J. (1965). What is a speech act? In P.P.Giglioli (ed.), Language and social context. Harmondsworth: Penguin Books, 1972, pp.136-155.
- Séguinot, A. (1968). Etude sur le degré de nasalité des voyelles nasales en français canadien et en français standard. In P.R.Léon (ed.), Recherches sur la structure phonique du français canadien. Montréal: Studia Phonetica, Didier, 1968, pp.88-100.

- Sherzer, J. and R. Darnell. (1972). Outline guide for the ethnographic study of speech use. In J.J. Gumperz and D. Hymes (eds.), Directions in sociolinguistics. New York: Holt, Rinehart and Winston, Inc. 1972, pp.548-555.
- Shuy, W.R. (1969). Sociolinguistic research at the Center for applied linguistics: the correlation of language and sex. In International congress of social sciences, Rome, 1969, pp.849-859.
- Soltész, J.A. (1970). Le parler des fies de Berthier-Sorel (Province de Québec, Canada), étude linguistique-aperçus ethnographiques. Unpublished Ph.D thesis. Université Laval, Québec.
- Statistiques-Canada: Recensement du Canada 1971. Population. Divisions et subdivisions de recensement (Québec), vol.1, Ottawa.
- Statistique et analyse linguistique. (1966). Colloque de Strasbourg, 20-23 avril 1964. Paris: Presses Universitaires de France.
- Statutes of Québec: Official Language Act, Bill no.22, assented to 31st July 1974.
- Straka, G. (1965). Album phonétique. Québec: Presses de l'Université Laval.
- Survey of Markets, 1971, published by the Financial Post. Toronto-Montréal: Maclean-Hunter.
- Swadesh, M. (1934). The phonemic principle. In E.C. Fudge (ed.), Phonology. Harmondsworth: Penguin Books, 1973, pp.35-47.
- Szmidt, Yvette. (1968). Etude de la phrase interrogative en français canadien et en français standard. In P.R. Léon (ed.), Recherches sur la structure phonique du français canadien. Montréal: Studia Phonetica, Didier, 1968, pp. 192-210.
- Tabouret-Keller, A. (1968). Sociological factors of language maintenance and language shift: a methodological approach based on European and African examples. In J.A. Fishman, C.A. Ferguson and J. Das Gupta (eds.), Language problems of developing nations. New York: Wiley, 1968, pp.107-119.
- Tanner, N. (1967). Speech and society among the Indonesian elite. A case study of a multilingual community. In J.B. Pride and J. Holmes (eds.), Sociolinguistics. Harmondsworth: Penguin Books, 1972, pp.125-142.

- Taylor, N.W. (1961). L'industriel canadien-français et son milieu. In M. Rioux and Y. Martin (eds.), La société canadienne-française. Montréal: ed. Hurtubise, 1971, pp. 279-303.
- Tessier, A. (1934). Trois-Rivières 1535-1935. Quatre siècles d'histoire. Trois-Rivières: Les Pages Trifluviennes-Série A- no 17.
- Tessier, A. (1935). Trois-Rivières. Trois-Rivières: Le Nouvelliste.
- The Principles of the International Phonetic Association. (1949). Reprinted 1970. London.
- Thériault, Y. (1954). Trois-Rivières. Ville de reflet. Trois-Rivières: ed. Bien Public.
- Tougas, G. (1956). Quelques aspects peu étudiés du français canadien. In Revue de l'Association Canadienne de linguistique, vol. 2, no. 2, 1956, pp. 60-66.
- Trager, G.L. (1958). Paralinguage: a first approximation. In D. Hymes (ed.), Language in culture and society. New York: Harper & Row, 1964, pp. 274-279.
- Trubetzkoy, N.S. (1939). Phonemes and how to determine them. In E.C. Fudge (ed.), Phonology. Harmondsworth: Penguin Books, 1973, pp. 47-74.
- Trudgill, P. (1972). Sex, covert prestige and linguistic change in the urban British English of Norwich. In Language in Society, vol. 1, 1972, pp. 179-196.
- Trudgill, P. (1973). Phonological rules and sociolinguistic variation in Norwich English. In C.-J. Bailey and R.W. Shuy (eds.), New Ways of Analyzing Variation in English. Washington, D.C.: Georgetown University Press, 1973, pp. 149-163.
- Trudgill, P. (1974). The social differentiation of English in Norwich. London: Cambridge University Press.
- Valdman, A. (1968). Language standardization in a diglossia situation: Haiti. In J.A. Fishman, C.A. Ferguson and J. Das Gupta (eds.), Language problems of developing nations. New York: Wiley, 1968, pp. 313-327.
- Valin, Roch. (1964). La méthode comparative en linguistique historique et en psychomécanique du langage. Québec: Presses de l'Université Laval.
- Van Den Berghe, P.L. (1968). Language and "Nationalism" in South Africa. In J.A. Fishman, C.A. Ferguson and J. Das Gupta (eds.), Language problems of developing nations. New York: Wiley, 1968, pp. 215-225.

- Vasek, A. (1969). Some remarks on sociolinguistics in monolingualism and plurilingualism. In International congress of social sciences, Rome, 1969, pp.871-881.
- Weinreich, U. (1953). Languages in Contact. The Hague: Mouton.
- Wells, J.C. (1970). A questionnaire for Jamaican English in London. London: University College
- Wells, J.C. (1971). Phonological adaptation in the speech of Jamaicans in the London area. Unpublished Ph.D. thesis, University of London.
- Whiteley, W.H. (1968). Ideal and reality in national language policy: a case study from Tanzania. In J.A. Fishman, C.A. Ferguson and J. Das Gupta (eds.), Language problems of developing nations. New York: Wiley, 1968, pp.327-345.
- Zima, P. (1969). Sur les possibilités et les limites de l'approche sociolinguistique dans la dialectologie africaine. In International congress of social sciences, Rome, 1969, pp.881-894.